

FIXING HOLES
SUITABLE FOR M5
SCREWS

FIXING HOLES
SUITABLE FOR M5
SCREWS

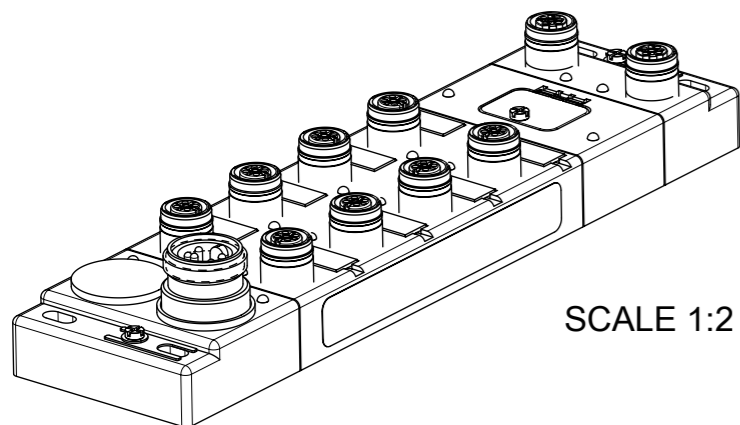

SCALE 1:2

SYMBOLS		THIS DRAWING CONTAINS INFORMATION THAT IS PROPRIETARY TO MOLEX ELECTRONIC TECHNOLOGIES, LLC AND SHOULD NOT BE USED WITHOUT WRITTEN PERMISSION	
DIMENSION UNITS	SCALE	CURRENT REV DESC:	
$\nabla = 0$	mm	molex IP67 I/O MODULES FOR MOTOR DRIVE ROLLERS	
$\nabla = 0$	GENERAL TOLERANCES (UNLESS SPECIFIED)		
$\nabla = 0$	ANGULAR TOL \pm		
$\nabla = 0$	4 PLACES \pm		
$\nabla = 0$	3 PLACES \pm	EC NO: 177447	2018/02/10
$\nabla = 0$	2 PLACES \pm	DRWN: SSM	2018/05/31
$\nabla = 0$	1 PLACE \pm	CHK'D: EDVESTU	2018/05/31
$\nabla = 0$	0 PLACES \pm	APPR: EDVESTU	2018/05/31
$\square = 0$	DRAFT WHERE APPLICABLE MUST REMAIN WITHIN DIMENSIONS	INITIAL REVISION:	
$\nabla = 0$		DRWN: SSM	2018/02/10
		APPR: EDVESTU	2018/05/31
		THIRD ANGLE PROJECTION	
		DRAWING	SERIES
		A3-SIZE	112072
		MATERIAL NUMBER	CUSTOMER
		1120725507	GENERAL MARKET
		DOC TYPE	DOC PART
		PSD	000
		REVISION	A
		SHEET NUMBER	1 OF 4

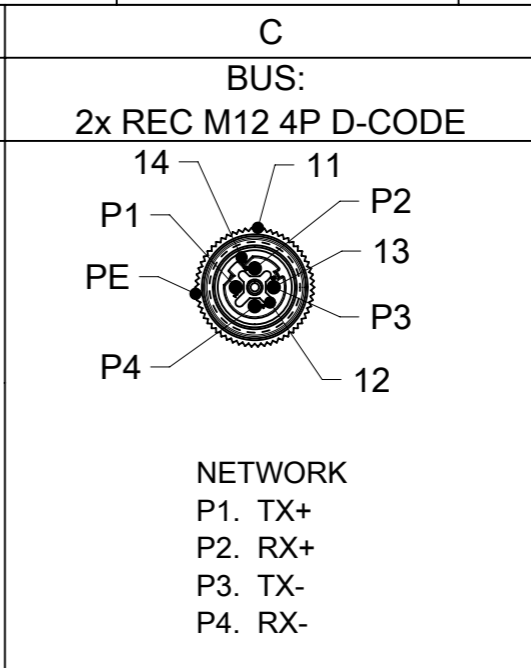
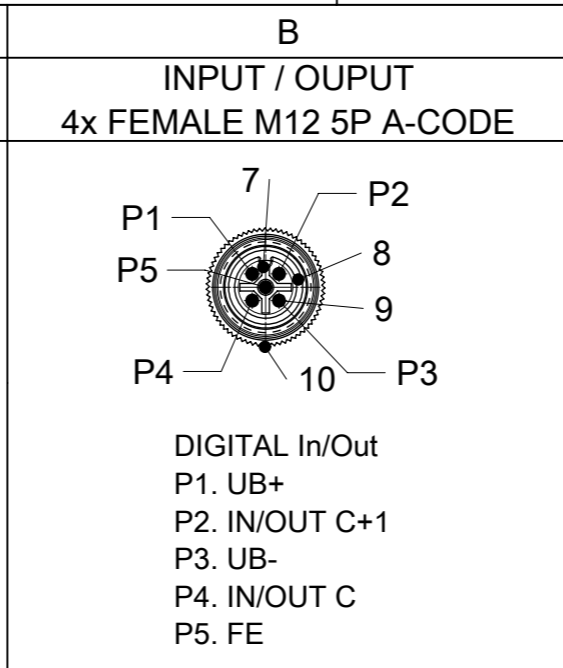
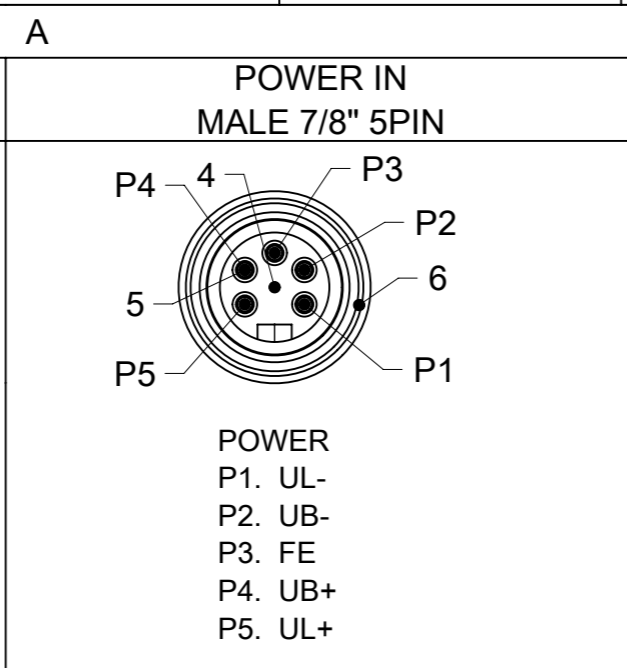
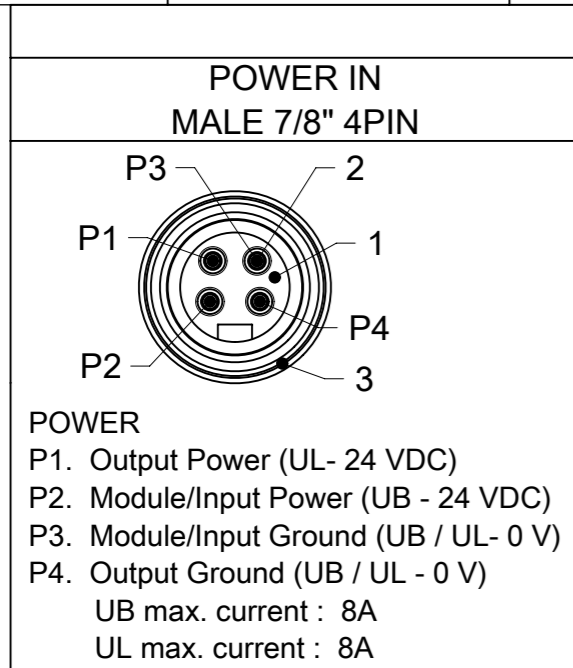

BILL OF MATERIAL

ITEM	DESCRIPTION	MATERIAL	FINISH
1	INSERT	TPE	YELLOW
2	CONTACT	BRASS ALLOY	GOLD OVER NICKEL
3	SHELL	BRASS	NICKEL PLATET
4	INSERT	TPE	YELLOW
5	CONTACT	BRONZE ALLOY	GOLD OVER NICKEL
6	SHELL	BRASS	NICKEL PLATET
7	INSERT	TPU	BLACK
8	GASKET	FPM	RED
9	CONTACT	BRASS	GOLD OVER NICKEL
10	SHELL	BRASS	NICKEL PLATET
11	SHELL	BRASS	NICKEL PLATET
12	INSERT	TPU	BLACK
13	CONTACT	BRASS	GOLD OVER NICKEL
14	GASKET	EPDM	VIOLET
15	HOUSING	PBT	GRAY
16	WINDOW	PC	TRANSPARENT
17	LABEL	PC	WHITE
18	FIBER OPTIC	PA	TRANSPARENT
19	WASHER	BRASS	NICKEL PLATET
20	SCREW	V2A	V2A
21	SHIELD PLATE	STAINLESS STEEL	STAINLESS STEEL
22	RESIN	EPOXY	TRANSPARENT
23	LABEL	PVC	WHITE
24	SHIELD CROSS	ZINC DIECAST	NICKEL PLATET

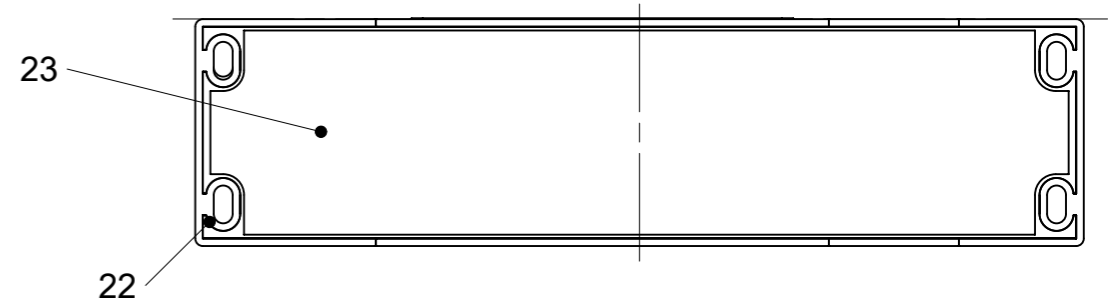
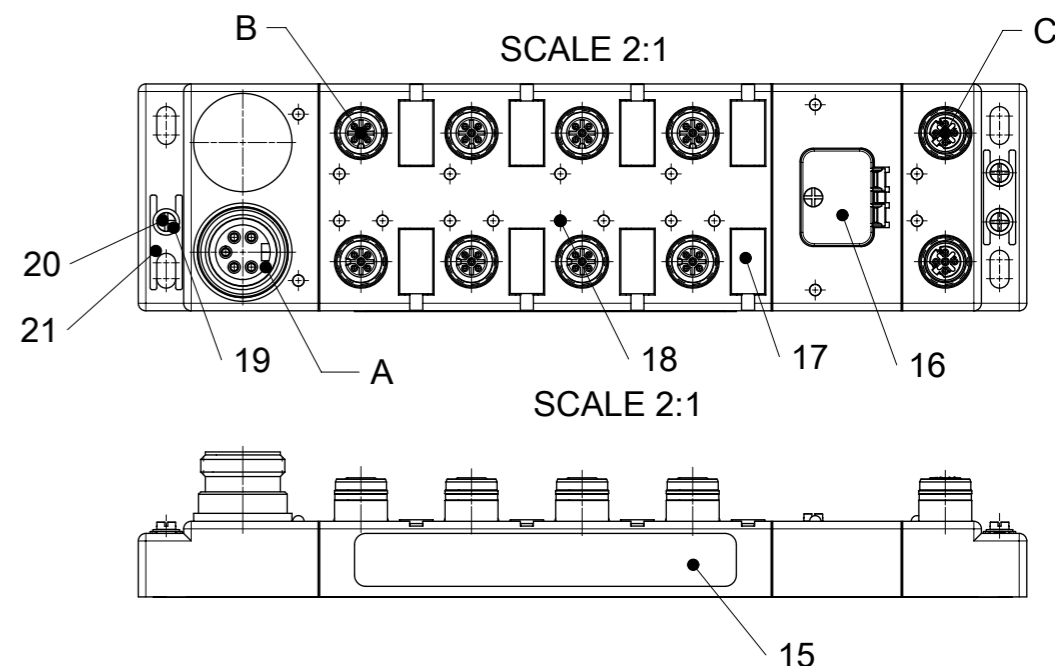
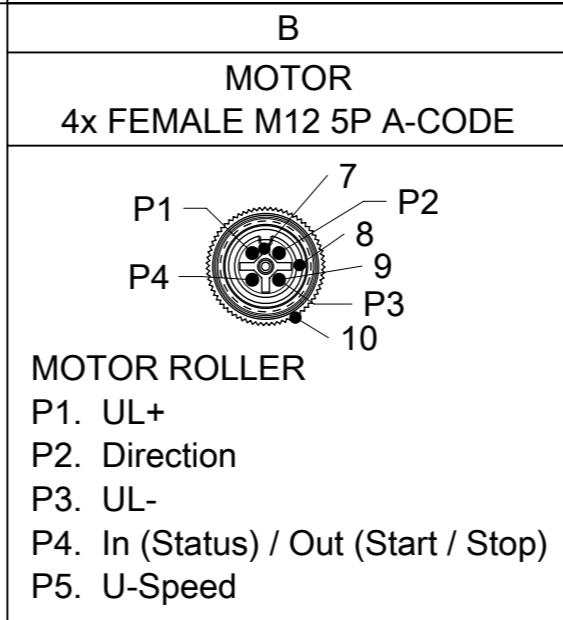

SYMBOLS DIMENSION UNITS: mm SCALE: (blank) GENERAL TOLERANCES (UNLESS SPECIFIED): ANGULAR TOL ± ° 4 PLACES ± 3 PLACES ± 2 PLACES ± 1 PLACE ± 0 PLACES ± DRAFT WHERE APPLICABLE MUST REMAIN WITHIN DIMENSIONS THIRD ANGLE PROJECTION	THIS DRAWING CONTAINS INFORMATION THAT IS PROPRIETARY TO MOLEX ELECTRONIC TECHNOLOGIES, LLC AND SHOULD NOT BE USED WITHOUT WRITTEN PERMISSION		CURRENT REV DESC: EC NO: 177447 DRWN: SSM 2018/02/10 CHK'D: EDVESTU 2018/05/31 APPR: EDVESTU 2018/05/31			
	IP67 I/O MODULES FOR MOTOR DRIVE ROLLERS					
	PRODUCT CUSTOMER DRAWING				DOCUMENT NUMBER: 1120725507 DOC TYPE: PSD DOC PART: 000 REVISION: A	
	DRAFT WHERE APPLICABLE MUST REMAIN WITHIN DIMENSIONS		DRAWING: A3-SIZE	SERIES: 112072	MATERIAL NUMBER: (blank)	CUSTOMER: GENERAL MARKET

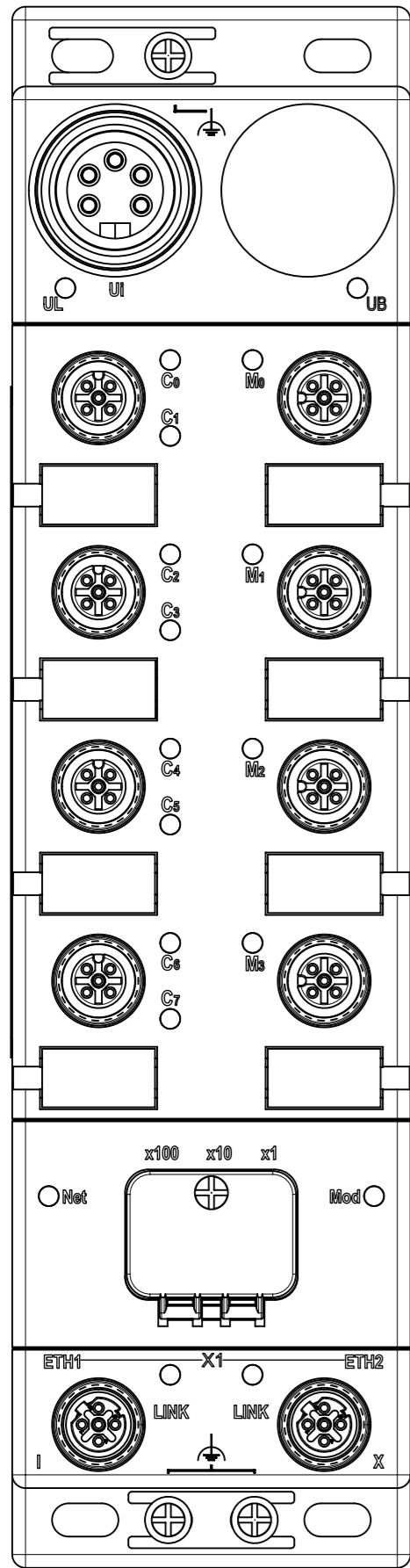

TABLE 1					
POWER TYPE	INPUT/OUTPUT	ENG. NO	P/N	NETWORK	3D MODEL NO.
7/8" 5 POLE	PNP	8 X CONFIGURABLE I/O 4 X MOTORS	TCDEI-8YMP-D1U-G	1120955157	ETHERNET/IP
			TCDEP-8YMP-D1U-G	1120955158	PROFINET
					1120725507 (PDM)

SYMBOLS ▽ = 0 ▽ = 0 ▽ = 0 ▽ = 0 ▽ = 0 ▽ = 0 ▽ = 0 ▽ = 0 ▽ = 0 ▽ = 0	THIS DRAWING CONTAINS INFORMATION THAT IS PROPRIETARY TO MOLEX ELECTRONIC TECHNOLOGIES, LLC AND SHOULD NOT BE USED WITHOUT WRITTEN PERMISSION	CURRENT REV DESC:			
	DIMENSION UNITS: mm	SCALE:	EC NO: 177447		IP67 I/O MODULES FOR MOTOR DRIVE ROLLERS PRODUCT CUSTOMER DRAWING
	GENERAL TOLERANCES (UNLESS SPECIFIED)		DRWN: SSM 2018/02/10		
	ANGULAR TOL ± °		CHK'D: EDVESTU 2018/05/31	DOCUMENT NUMBER: 1120725507 DOC TYPE: PSD DOC PART: 000 REVISION: A	
	4 PLACES ±		APPR: EDVESTU 2018/05/31		
	3 PLACES ±		INITIAL REVISION:	MATERIAL NUMBER: 112072 CUSTOMER: GENERAL MARKET SHEET NUMBER: 3 OF 4	
	2 PLACES ±		DRWN: SSM 2018/02/10		
	1 PLACE ±		APPR: EDVESTU 2018/05/31		
	0 PLACES ±		THIRD ANGLE PROJECTION	DRAWING: A3-SIZE	
	DRAFT WHERE APPLICABLE MUST REMAIN WITHIN DIMENSIONS		SERIES: 112072		

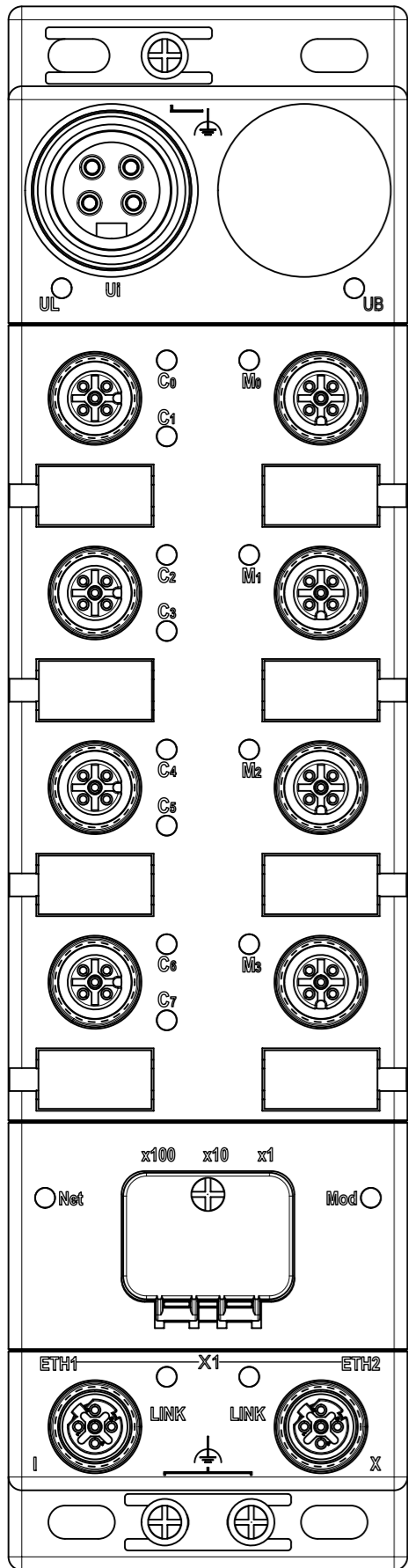

TABLE 1						
POWER TYPE	INPUT/OUTPUT		ENG. NO	P/N	NETWORK	3D MODEL NO.
7/8" 4 POLE	PNP	8 X CONFIGURABLE I/O 4 X MOTORS	TCDEI-8YMP-DYU-G	1120955156	ETHERNET /IP	1120725506 (PDM)

SYMBOLS	THIS DRAWING CONTAINS INFORMATION THAT IS PROPRIETARY TO MOLEX ELECTRONIC TECHNOLOGIES, LLC AND SHOULD NOT BE USED WITHOUT WRITTEN PERMISSION		CURRENT REV DESC:		molex			
	DIMENSION UNITS	SCALE						IP67 I/O MODULES FOR MOTOR DRIVE ROLLERS
	mm		PRODUCT CUSTOMER DRAWING					
	GENERAL TOLERANCES (UNLESS SPECIFIED)		INITIAL REVISION:			DOCUMENT NUMBER		
	ANGULAR TOL	±	°	DRWN: SSM 2018/02/10		1120725507		
4 PLACES	±		CHK'D: EDVESTU 2018/05/31		DOC TYPE			
3 PLACES	±		APPR: EDVESTU 2018/05/31		PSD			
2 PLACES	±		DRWN: SSM 2018/02/10		DOC PART			
1 PLACE	±		APPR: EDVESTU 2018/05/31		000			
0 PLACES	±				REVISION			
					A			
DRAFT WHERE APPLICABLE MUST REMAIN WITHIN DIMENSIONS	THIRD ANGLE PROJECTION		DRAWING	SERIES	MATERIAL NUMBER	CUSTOMER	SHEET NUMBER	
			A3-SIZE	112072		GENERAL MARKET	4 OF 4	