

## Dual SPDT Analog Switch

### DESCRIPTION

The DG9636 is a CMOS, dual SPDT analog switch designed to operate from 2.7 V to 12 V, single supply. All control logic inputs have a guaranteed 1.65 V logic HIGH threshold when operation from a 12 V power supply. This makes the DG9636 ideally suited to interface directly with low voltage micro-processor control signals.

Processed with high density CMOS technology, the DG9636 has a  $83\ \Omega$  channel ON resistance while providing ultra low parasitic capacitance of 2 pF for  $C_{S(off)}$  and 7 pF for  $C_{D(on)}$ . Other performance features are: 720 MHz -3 dB bandwidth, -67 dB Cross Talk and -58 dB Off isolation at 10 MHz frequency.

Key applications for the DG9636 are logic level translation, pulse generator, and high speed or low noise signal switching in precision instrumentations and portable device designs.

The DG9636 is available in space saving 1.4 mm x 1.8 mm miniQFN10 package.

As a committed partner to the community and the environment, Vishay Siliconix manufactures this product with lead (Pb)-free device termination. The miniQFN-10 package has a nickel-palladium-gold device termination and is represented by the lead (Pb)-free “-E4” suffix to the ordering part number. The nickel-palladium-gold device terminations meet all JEDEC® standards for reflow and MSL rating.

### FEATURES

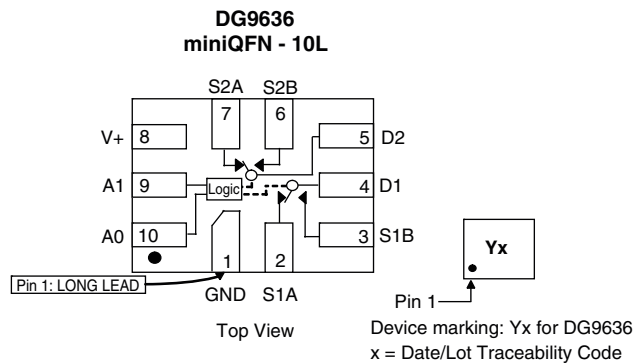
- Leakage current < 0.5 nA max. at 85 °C
- Low switch capacitance ( $C_{S(off)}$ , 2 pF typ.)
- $R_{DS(on)}$  -83  $\Omega$  max.
- Low voltage, 1.65 V CMOS/TTL compatible
- 720 MHz, -3 dB bandwidth
- Fully specified with single supply operation at 12 V
- Excellent isolation and crosstalk performance (typ. > -60 dB at 10 MHz)
- Fully specified from -40 °C to 85 °C and -40 °C to +125 °C
- Latch-up current 300 mA per JESD78
- Lead (Pb)-free low profile miniQFN-10 (1.4 mm x 1.8 mm x 0.55 mm)
- Material categorization: For definitions of compliance please see [www.vishay.com/doc?99912](http://www.vishay.com/doc?99912)


**RoHS**  
COMPLIANT

### APPLICATIONS

- High-end data acquisition
- Medical instruments
- Precision instruments
- High speed communications applications
- Automated test equipment
- Sample and hold applications

### FUNCTIONAL BLOCK DIAGRAM AND PIN CONFIGURATION



| TRUTH TABLE    |    |             |
|----------------|----|-------------|
| Selected Input |    | On Switches |
| A1             | A0 | DG9636      |
| X              | 0  | D1 to S1A   |
| X              | 1  | D1 to S1B   |
| 0              | X  | D2 to S2A   |
| 1              | X  | D2 to S2B   |



| ORDERING INFORMATION |                |                |
|----------------------|----------------|----------------|
| Temp. Range          | Package        | Part Number    |
| -40 °C to 125 °C     | 10 pin miniQFN | DG9636EN-T1-E4 |
| -40 °C to 85 °C      | 10 pin miniQFN | DG9636DN-T1-E4 |

**Note**

- 40 °C to 85 °C datasheet limits apply.

| ABSOLUTE MAXIMUM RATINGS (T <sub>A</sub> = 25 °C, unless otherwise noted) |  |      |
|---|--|------|
| Parameter   | Limit                                      | Unit |
| V+ to GND   | 14   | V    |
| Digital Inputs <sup>a</sup> , V <sub>S</sub> , V <sub>D</sub>             | (V+) +0.3 or 30 mA, whichever occurs first |      |
| Continuous Current (Any Terminal)   | 30   | mA   |
| Peak Current, S or D (Pulsed 1 ms, 10 % Duty Cycle)                       | 100  |      |
| Storage Temperature   | -65 to 150                                 | °C   |
| Power Dissipation (Package) <sup>b</sup>                                  | 10 pin miniQFN <sup>c, d</sup>             | 208  |
| Thermal Resistance (Package) <sup>b</sup>                                 | 10 pin miniQFN                             | 357  |

**Notes**

- Signals on SX, DX, or AX exceeding V+ or V- will be clamped by internal diodes. Limit forward diode current to maximum current ratings.
- All leads welded or soldered to PC board.
- Derate 2.6 mW/°C above 70 °C.
- Manual soldering with iron is not recommended for leadless components. The miniQFN-10 is a leadless package. The end of the lead terminal is exposed copper (not plated) as a result of the singulation process in manufacturing. A solder fillet at the exposed copper lip cannot be guaranteed and is not required to ensure adequate bottom side solder interconnection.

| SPECIFICATIONS                      |                       |  |                    |                   |                   |                   |                   |                   |      |
|-------------------------------------|-----------------------|--|--------------------|-------------------|-------------------|-------------------|-------------------|-------------------|------|
| Parameter                           | Symbol                | Test Conditions<br>Unless Otherwise Specified<br>V+ = 12 V, V <sub>A0, A1</sub> = 1.65 V, 0.5 V <sup>a</sup> | Temp. <sup>b</sup> | Typ. <sup>c</sup> | -40 °C to 125 °C  |                   | -40 °C to 85 °C   |                   | Unit |
|                                     |                       |  |                    |                   | Min. <sup>d</sup> | Max. <sup>d</sup> | Min. <sup>d</sup> | Max. <sup>d</sup> |      |
| <b>Analog Switch</b>                |                       |  |                    |                   |                   |                   |                   |                   |      |
| Analog Signal Range <sup>e</sup>    | V <sub>ANALOG</sub>   |  | Full               | -                 | -                 | 12                | -                 | 12                | V    |
| On-Resistance                       | R <sub>DS(on)</sub>   | I <sub>S</sub> = 1 mA, V <sub>D</sub> = +11.3 V  | Room               | 83                | -                 | 110               | -                 | 110               | Ω    |
|                                     |                       |  | Full               | -                 | -                 | 140               | -                 | 125               |      |
| On-Resistance Match                 | ΔR <sub>on</sub>      | I <sub>S</sub> = 1 mA, V <sub>D</sub> = +11.3 V  | Room               | 2                 | -                 | 4                 | -                 | 4                 | Ω    |
|                                     |                       |  | Full               | -                 | -                 | 9                 | -                 | 6                 |      |
| On-Resistance Flatness              | R <sub>FLATNESS</sub> | I <sub>S</sub> = 1 mA, V <sub>D</sub> = 0.7 V, 6.5 V, 11.3 V   | Room               | 33                | -                 | 45                | -                 | 45                | Ω    |
|                                     |                       |  | Full               | -                 | -                 | 55                | -                 | 50                |      |
| Switch Off Leakage Current          | I <sub>S(off)</sub>   | V+ = 12 V,<br>V <sub>D</sub> = 1 V/11 V, V <sub>S</sub> = 11 V/1 V   | Room               | ± 0.01            | -1                | 1                 | -1                | 1                 | nA   |
|                                     |                       |  | Full               | -                 | -18               | 18                | -2                | 2                 |      |
|                                     | Room                  |  | ± 0.01             | -1                | 1                 | -1                | 1                 |                   |      |
|                                     | Full                  |  | -                  | -18               | 18                | -2                | 2                 |                   |      |
| Channel On Leakage Current          | I <sub>D(on)</sub>    | V+ = 12 V,<br>V <sub>D</sub> = V <sub>S</sub> 11 V/1 V   | Room               | ± 0.01            | -1                | 1                 | -1                | 1                 |      |
|                                     |                       |  | Full               | -                 | -18               | 18                | -2                | 2                 |      |
| <b>Digital Control</b>              |                       |  |                    |                   |                   |                   |                   |                   |      |
| Input Current, V <sub>IN</sub> Low  | I <sub>IL</sub>       | V <sub>AX</sub> = 0.5 V  | Full               | 0.005             | -0.1              | 0.1               | -0.1              | 0.1               | μA   |
| Input Current, V <sub>IN</sub> High | I <sub>IH</sub>       | V <sub>AX</sub> = 1.65 V   | Full               | 0.005             | -0.1              | 0.1               | -0.1              | 0.1               |      |
| Input Capacitance <sup>e</sup>      | C <sub>IN</sub>       | f = 1 MHz  | Room               | 3                 | -                 | -                 | -                 | -                 | pF   |



| SPECIFICATIONS                            |              |  |                    |                   |                   |                   |                   |                   |               |
|---|--------------|--|--------------------|-------------------|-------------------|-------------------|-------------------|-------------------|---------------|
| Parameter                                 | Symbol       | Test Conditions<br>Unless Otherwise Specified<br>$V_+ = 12\text{ V}$ , $V_{A0, A1} = 1.65\text{ V}$ , $0.5\text{ V}^a$ | Temp. <sup>b</sup> | Typ. <sup>c</sup> | -40 °C to 125 °C  |                   | -40 °C to 85 °C   |                   | Unit          |
|   |              |  |                    |                   | Min. <sup>d</sup> | Max. <sup>d</sup> | Min. <sup>d</sup> | Max. <sup>d</sup> |               |
| <b>Dynamic Characteristics</b>            |              |  |                    |                   |                   |                   |                   |                   |               |
| Turn-On Time                              | $t_{on}$     | $R_L = 300\ \Omega$ , $C_L = 35\text{ pF}$<br>see figure 1, 2  | Room               | 30                | -                 | 70                | -                 | 70                | ns            |
|   |              |  | Full               | -                 | -                 | 90                | -                 | 80                |               |
| Turn-Off Time                             | $t_{off}$    |  | Room               | 15                | -                 | 55                | -                 | 55                |               |
|   |              |  | Full               | -                 | -                 | 75                | -                 | 65                |               |
| Break-Before-Make                         | $t_{BBM}$    |  | Room               | 15                | 5                 | -                 | 5                 | -                 |               |
|   |              |  | Full               | -                 | 2                 | -                 | 2                 | -                 |               |
| Charge Injection <sup>e</sup>             | $Q_{INJ}$    | $V_g = 0\text{ V}$ , $R_g = 0\ \Omega$ , $C_L = 1\text{ nF}$   | Room               | 23.5              | -                 | -                 | -                 | -                 | pC            |
| Off Isolation <sup>e</sup>                | OIRR         | $R_L = 50\ \Omega$ , $C_L = 5\text{ pF}$ , $f = 10\text{ MHz}$   | Room               | -58               | -                 | -                 | -                 | -                 | dB            |
| Bandwidth <sup>e</sup>                    | BW           | $R_L = 50\ \Omega$   | Room               | 720               | -                 | -                 | -                 | -                 | MHz           |
| Channel-to-Channel Crosstalk <sup>e</sup> | $X_{TALK}$   | $R_L = 50\ \Omega$ , $C_L = 5\text{ pF}$ , $f = 10\text{ MHz}$   | Room               | -67               | -                 | -                 | -                 | -                 | dB            |
| <b>Dynamic Characteristics</b>            |              |  |                    |                   |                   |                   |                   |                   |               |
| Source Off Capacitance <sup>e</sup>       | $C_{S(off)}$ | $f = 1\text{ MHz}$   | Room               | 2                 | -                 | -                 | -                 | -                 | pF            |
| Channel On Capacitance <sup>e</sup>       | $C_{D(on)}$  |  | Room               | 7.7               | -                 | -                 | -                 | -                 |               |
| Total Harmonic Distortion <sup>e</sup>    | THD          | Signal = $1\text{ V}_{RMS}$ , 20 Hz to 20 kHz,<br>$R_L = 600\ \Omega$  | Room               | 0.01              | -                 | -                 | -                 | -                 | %             |
| <b>Power Supplies</b>                     |              |  |                    |                   |                   |                   |                   |                   |               |
| Power Supply Current                      | $I_+$        | $V_{IN} = 0\text{ V}$ , or $V_+$   | Room               | 0.001             | -                 | 0.5               | -                 | 0.5               | $\mu\text{A}$ |
|   |              |  | Full               | -                 | -                 | 1                 | -                 | 1                 |               |
| Ground Current                            | $I_{GND}$    |  | Room               | -0.001            | -0.5              | -                 | -0.5              | -                 |               |
|   |              |  | Full               | -                 | -1                | -                 | -1                | -                 |               |

| SPECIFICATIONS                   |                 |  |                         |                   |                   |                   |                   |                   |          |     |               |
|----------------------------------|-----------------|--|-------------------------|-------------------|-------------------|-------------------|-------------------|-------------------|----------|-----|---------------|
| Parameter                        | Symbol          | Test Conditions<br>Unless Otherwise Specified<br>$V_+ = 5\text{ V}$ , $V_{A0, A1} = 1.4\text{ V}$ , $0.5\text{ V}^a$ | Temp. <sup>b</sup>      | Typ. <sup>c</sup> | -40 °C to 125 °C  |                   | -40 °C to 85 °C   |                   | Unit     |     |               |
|                                  |                 |  |                         |                   | Min. <sup>d</sup> | Max. <sup>d</sup> | Min. <sup>d</sup> | Max. <sup>d</sup> |          |     |               |
| <b>Analog Switch</b>             |                 |  |                         |                   |                   |                   |                   |                   |          |     |               |
| Analog Signal Range <sup>e</sup> | $V_{ANALOG}$    |  | Full                    | -                 | -                 | 5                 | -                 | 5                 | V        |     |               |
| On-Resistance                    | $R_{DS(on)}$    | $I_S = 1\text{ mA}$ , $V_D = +3.5\text{ V}$  | Room                    | 120               | -                 | 170               | -                 | 170               | $\Omega$ |     |               |
|                                  |                 |  | Full                    | -                 | -                 | 250               | -                 | 200               |          |     |               |
| On-Resistance Match              | $\Delta R_{on}$ |  | Room                    | 3                 | -                 | 5                 | -                 | 5                 |          |     |               |
|                                  |                 |  | Full                    | -                 | -                 | 12                | -                 | 10                |          |     |               |
| Switch Off Leakage Current       | $I_{S(off)}$    | $V_+ = 5.5\text{ V}$ ,<br>$V_D = 1\text{ V}/4.5\text{ V}$ , $V_S = 4.5\text{ V}/1\text{ V}$                          | Room                    | $\pm 0.01$        | -1                | 1                 | -1                | 1                 | nA       |     |               |
|                                  |                 |  | Full                    | -                 | -18               | 18                | -2                | 2                 |          |     |               |
|                                  | $I_{D(off)}$    |  | Room                    | $\pm 0.01$        | -1                | 1                 | -1                | 1                 |          |     |               |
|                                  |                 |  | Full                    | -                 | -18               | 18                | -2                | 2                 |          |     |               |
| Channel On Leakage Current       | $I_{D(on)}$     |  | Room                    | $\pm 0.01$        | -1                | 1                 | -1                | 1                 |          |     |               |
|                                  |                 |  | Full                    | -                 | -18               | 18                | -2                | 2                 |          |     |               |
| <b>Digital Control</b>           |                 |  |                         |                   |                   |                   |                   |                   |          |     |               |
| Input Current, $V_{IN}$ Low      | $I_L$           |  | $V_{AX} = 0.5\text{ V}$ | Full              | 0.005             | -0.1              | 0.1               | -0.1              |          | 0.1 | $\mu\text{A}$ |
| Input Current, $V_{IN}$ High     | $I_H$           | $V_{AX} = 1.4\text{ V}$  | Full                    | 0.005             | -0.1              | 0.1               | -0.1              | 0.1               |          |     |               |
| Input Capacitance                | $C_{IN}$        | $f = 1\text{ MHz}$   | Room                    | 3                 | -                 | -                 | -                 | -                 | pF       |     |               |



| SPECIFICATIONS                         |              |   |                    |                   |                   |                   |                   |                   |               |
|--|--------------|---|--------------------|-------------------|-------------------|-------------------|-------------------|-------------------|---------------|
| Parameter                              | Symbol       | Test Conditions<br>Unless Otherwise Specified<br>$V_+ = 5\text{ V}$ , $V_{A0,A1} = 1.4\text{ V}$ , $0.5\text{ V}^a$ | Temp. <sup>b</sup> | Typ. <sup>c</sup> | -40 °C to 125 °C  |                   | -40 °C to 85 °C   |                   | Unit          |
|  |              |   |                    |                   | Min. <sup>d</sup> | Max. <sup>d</sup> | Min. <sup>d</sup> | Max. <sup>d</sup> |               |
| <b>Dynamic Characteristics</b>         |              |   |                    |                   |                   |                   |                   |                   |               |
| Turn-On Time                           | $t_{on}$     | $R_L = 300\ \Omega$ , $C_L = 35\text{ pF}$<br>see figure 1, 2   | Room               | 55                | -                 | -                 | -                 | -                 | ns            |
|  |              |   | Full               | -                 | -                 | -                 | -                 | -                 |               |
| Turn-Off Time                          | $t_{off}$    |   | Room               | 30                | -                 | -                 | -                 | -                 |               |
|  |              |   | Full               | -                 | -                 | -                 | -                 | -                 |               |
| Break-Before-Make-Time                 | $t_{BMM}$    |   | Room               | 36                | -                 | -                 | -                 | -                 |               |
|  |              |   | Full               | -                 | -                 | -                 | -                 | -                 |               |
| Charge Injection <sup>e</sup>          | $Q_{INJ}$    | $C_L = 1\text{ nF}$ , $R_{GEN} = 0\ \Omega$ , $V_{GEN} = 0\text{ V}$  | Full               | 10                | -                 | -                 | -                 | -                 | pC            |
| Off-Isolation <sup>e</sup>             | OIRR         | $f = 10\text{ MHz}$ , $R_L = 50\ \Omega$ , $C_L = 5\text{ pF}$  | Room               | -58               | -                 | -                 | -                 | -                 | dB            |
| Crosstalk <sup>e</sup>                 | $X_{TALK}$   |   | Room               | -68               | -                 | -                 | -                 | -                 |               |
| Bandwidth <sup>e</sup>                 | BW           | $R_L = 50\ \Omega$  | Room               | 610               | -                 | -                 | -                 | -                 | MHz           |
| Total Harmonic Distortion <sup>e</sup> | THD          | Signal = $1\text{ V}_{RMS}$ , 20 Hz to 20 kHz,<br>$R_L = 600\ \Omega$   | Room               | 2.2               | -                 | -                 | -                 | -                 | %             |
| Source Off Capacitance <sup>e</sup>    | $C_{S(off)}$ | $f = 1\text{ MHz}$  | Room               | 2.1               | -                 | -                 | -                 | -                 | pF            |
| Channel On Capacitance <sup>e</sup>    | $C_{D(on)}$  |   |                    | 8.1               | -                 | -                 | -                 | -                 |               |
| <b>Power Supplies</b>                  |              |   |                    |                   |                   |                   |                   |                   |               |
| Power Supply Current                   | $I_+$        | $V_{IN} = 0\text{ V}$ , or $V_+$  | Room               | 0.001             | -                 | 0.5               | -                 | 0.5               | $\mu\text{A}$ |
|  |              |   | Full               | -                 | -                 | 1                 | -                 | 1                 |               |
| Ground Current                         | $I_{GND}$    |   | Room               | -0.001            | -0.5              | -                 | -0.5              | -                 |               |
|  |              |   | Full               | -                 | -1                | -                 | -1                | -                 |               |

| SPECIFICATIONS                                     |                 |   |                    |                   |                   |                   |                   |                   |               |
|--|-----------------|---|--------------------|-------------------|-------------------|-------------------|-------------------|-------------------|---------------|
| Parameter  | Symbol          | Test Conditions<br>Unless Otherwise Specified<br>$V_+ = 3\text{ V}$ , $V_{A0,A1} = 1.4\text{ V}$ , $0.5\text{ V}^a$ | Temp. <sup>b</sup> | Typ. <sup>c</sup> | -40 °C to 125 °C  |                   | -40 °C to 85 °C   |                   | Unit          |
|  |                 |   |                    |                   | Min. <sup>d</sup> | Max. <sup>d</sup> | Min. <sup>d</sup> | Max. <sup>d</sup> |               |
| <b>Analog Switch</b>                               |                 |   |                    |                   |                   |                   |                   |                   |               |
| Analog Signal Range <sup>e</sup>                   | $V_{ANALOG}$    |   | Full               | -                 | -                 | 3                 | -                 | 3                 | V             |
| On-Resistance                                      | $R_{DS(on)}$    | $I_S = 1\text{ mA}$ , $V_D = +1.5\text{ V}$   | Room               | 200               | -                 | 245               | -                 | 245               | $\Omega$      |
|  |                 |   | Full               | -                 | -                 | 325               | -                 | 290               |               |
| On-Resistance Match                                | $\Delta R_{on}$ |   | Room               | 5                 | -                 | 6                 | -                 | 6                 |               |
|  |                 |   | Full               | -                 | -                 | 13                | -                 | 11                |               |
| Switch Off Leakage Current<br>(for 16 pin miniQFN) | $I_{S(off)}$    | $V_+ = 3.3\text{ V}$ , $V_- = 0\text{ V}$<br>$V_D = 1\text{ V}/3\text{ V}$ , $V_S = 3\text{ V}/1\text{ V}$          | Room               | $\pm 0.01$        | -1                | 1                 | -1                | 1                 | nA            |
|  |                 |   | Full               | -                 | -18               | 18                | -2                | 2                 |               |
|  | Room            |   | $\pm 0.01$         | -1                | 1                 | -1                | 1                 |                   |               |
|  | Full            |   | -                  | -18               | 18                | -2                | 2                 |                   |               |
| Channel On Leakage Current<br>(for 16 pin miniQFN) | $I_{D(on)}$     | $V_+ = 3.3\text{ V}$ , $V_- = 0\text{ V}$ ,<br>$V_S = V_D = 1\text{ V}/3\text{ V}$                                  | Room               | $\pm 0.01$        | -1                | 1                 | -1                | 1                 |               |
|  |                 |   | Full               | -                 | -18               | 18                | -2                | 2                 |               |
| <b>Digital Control</b>                             |                 |   |                    |                   |                   |                   |                   |                   |               |
| Input Current, $V_{IN}$ Low                        | $I_L$           | $V_{AX} = 0.5\text{ V}$   | Full               | 0.005             | -0.1              | 0.1               | -0.1              | 0.1               | $\mu\text{A}$ |
| Input Current, $V_{IN}$ High                       | $I_H$           | $V_{AX} = 1.4\text{ V}$   | Full               | 0.005             | -0.1              | 0.1               | -0.1              | 0.1               |               |
| Input Capacitance                                  | $C_{IN}$        | $f = 1\text{ MHz}$  | Room               | 3.1               | -                 | -                 | -                 | -                 | pF            |



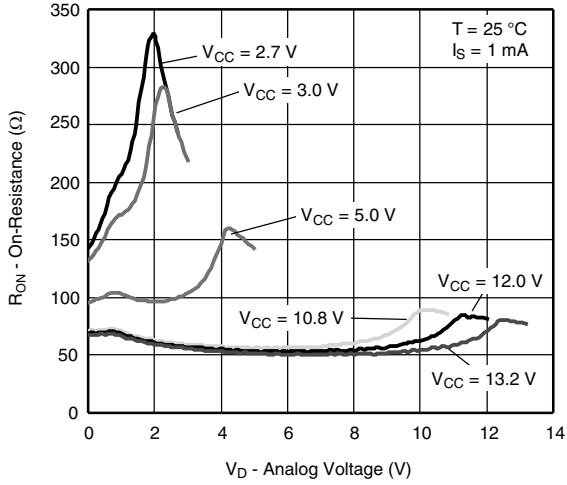
| SPECIFICATIONS                         |              |  |                    |                   |                   |                   |                   |                   |               |
|--|--------------|--|--------------------|-------------------|-------------------|-------------------|-------------------|-------------------|---------------|
| Parameter                              | Symbol       | Test Conditions<br>Unless Otherwise Specified<br>$V_+ = 3\text{ V}$ , $V_{A0, A1} = 1.4\text{ V}$ , $0.5\text{ V}^a$ | Temp. <sup>b</sup> | Typ. <sup>c</sup> | -40 °C to 125 °C  |                   | -40 °C to 85 °C   |                   | Unit          |
|  |              |  |                    |                   | Min. <sup>d</sup> | Max. <sup>d</sup> | Min. <sup>d</sup> | Max. <sup>d</sup> |               |
| <b>Dynamic Characteristics</b>         |              |  |                    |                   |                   |                   |                   |                   |               |
| Enable Turn-On Time                    | $t_{on}$     | $R_L = 300\ \Omega$ , $C_L = 35\text{ pF}$<br>see figure 1, 2  | Room               | 96                | -                 | -                 | -                 | -                 | ns            |
|  |              |  | Full               | -                 | -                 | -                 | -                 | -                 |               |
| Enable Turn-Off Time                   | $t_{off}$    |  | Room               | 60                | -                 | -                 | -                 | -                 |               |
|  |              |  | Full               | -                 | -                 | -                 | -                 | -                 |               |
| Break-Before-Make-Time                 | $t_{BMM}$    |  | Room               | 77                | -                 | -                 | -                 | -                 |               |
|  |              |  | Full               | -                 | -                 | -                 | -                 | -                 |               |
| Charge Injection <sup>e</sup>          | $Q_{INJ}$    | $C_L = 1\text{ nF}$ , $R_{GEN} = 0\ \Omega$ , $V_{GEN} = 0\text{ V}$   | Full               | 6.6               | -                 | -                 | -                 | -                 | pC            |
| Off-Isolation <sup>e</sup>             | OIRR         | $f = 10\text{ MHz}$ , $R_L = 50\ \Omega$ , $C_L = 5\text{ pF}$   | Room               | -57               | -                 | -                 | -                 | -                 | dB            |
| Crosstalk <sup>e</sup>                 | $X_{TALK}$   |  | Room               | -69               | -                 | -                 | -                 | -                 |               |
| Bandwidth <sup>e</sup>                 | BW           | $R_L = 50\ \Omega$   | Room               | 525               | -                 | -                 | -                 | -                 | MHz           |
| Total Harmonic Distortion <sup>e</sup> | THD          | Signal = $1\text{ V}_{RMS}$ , 20 Hz to 20 kHz,<br>$R_L = 600\ \Omega$  | Room               | 2.2               | -                 | -                 | -                 | -                 | %             |
| Source Off Capacitance <sup>e</sup>    | $C_{S(off)}$ | $f = 1\text{ MHz}$   | Room               | 2.1               | -                 | -                 | -                 | -                 | pF            |
| Channel On Capacitance <sup>e</sup>    | $C_{D(on)}$  |  | Room               | 8.3               | -                 | -                 | -                 | -                 |               |
| <b>Power Supplies</b>                  |              |  |                    |                   |                   |                   |                   |                   |               |
| Power Supply Current                   | $I_+$        | $V_{IN} = 0\text{ V}$ , or $V_+$   | Room               | 0.001             | -                 | 0.5               | -                 | 0.5               | $\mu\text{A}$ |
|  |              |  | Full               | -                 | -                 | 1                 | -                 | 1                 |               |
| Ground Current                         | $I_{GND}$    |  | Room               | -0.001            | -0.5              | -                 | -0.5              | -                 |               |
|  |              |  | Full               | -                 | -1                | -                 | -1                | -                 |               |

**Notes**

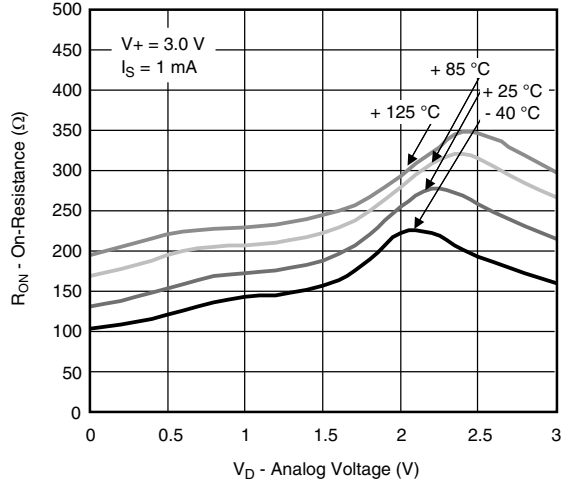
- a.  $V_{IN}$  = input voltage to perform proper function.
- b. Room = 25 °C, Full = as determined by the operating temperature.
- c. Typical value are for DESIGN AID ONLY, not guaranteed nor subject to production testing.
- d. The algebraic convention whereby the most negative value is a minimum and the most positive a maximum, is used in this datasheet.
- e. Guaranteed by design, not subject to production test.

*Stresses beyond those listed under "Absolute Maximum Ratings" may cause permanent damage to the device. These are stress ratings only, and functional operation of the device at these or any other conditions beyond those indicated in the operational sections of the specifications is not implied. Exposure to absolute maximum rating conditions for extended periods may affect device reliability.*

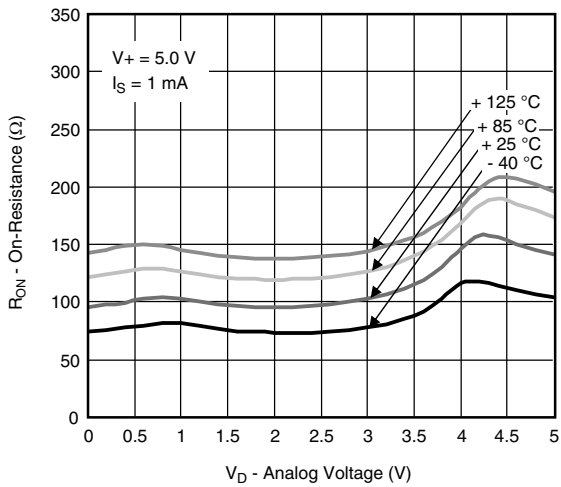
**TYPICAL CHARACTERISTICS** (25 °C, unless otherwise noted)



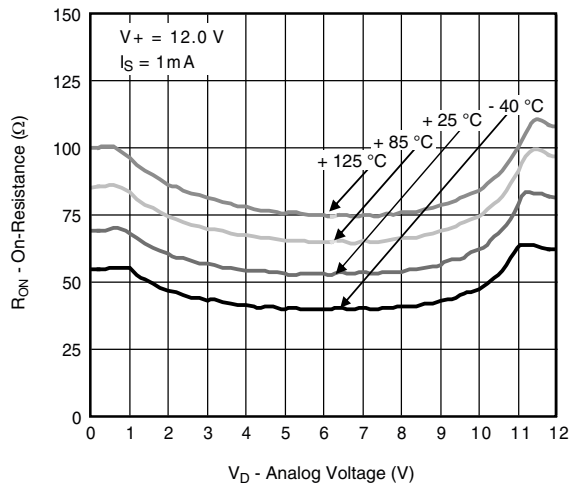
**On-Resistance vs. Single Supply Voltage**



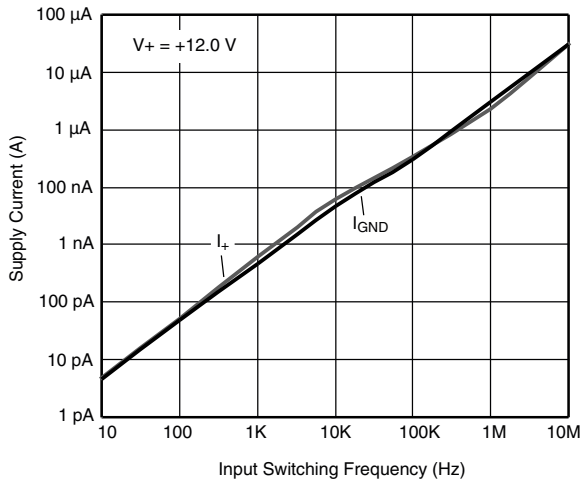
**On-Resistance vs. Analog Voltage and Temperature**



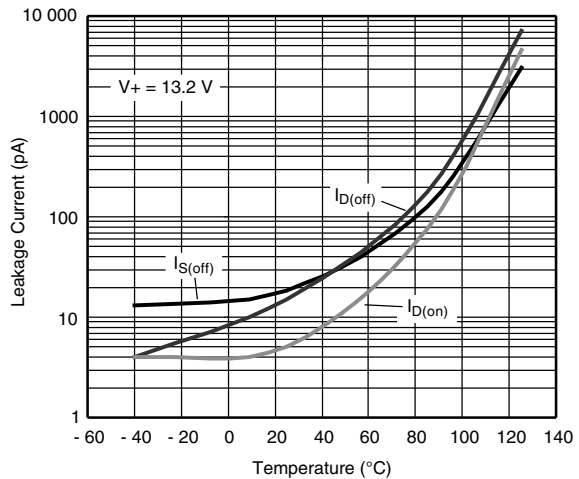
**On-Resistance vs. Analog Voltage and Temperature**



**On-Resistance vs. Analog Voltage and Temperature**

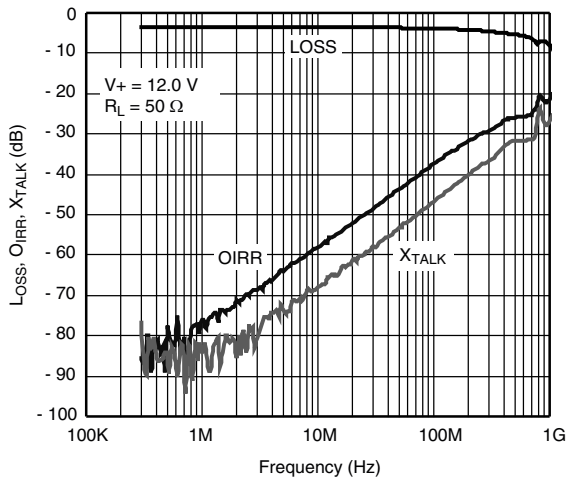


**Supply Current vs. Input Switching Frequency**

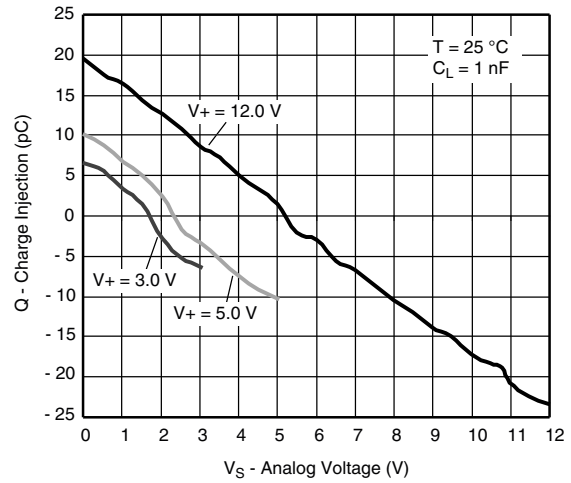


**Leakage Current vs. Temperature**

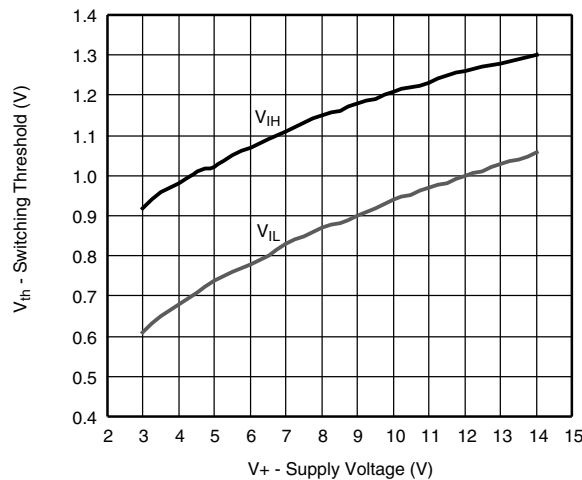
**TYPICAL CHARACTERISTICS** (25 °C, unless otherwise noted)



**Insertion Loss, Off-Isolation, Crosstalk vs. Frequency**



**Charge Injection vs. Analog voltage**



**Switching Threshold vs. Supply Voltage**

TEST CIRCUITS

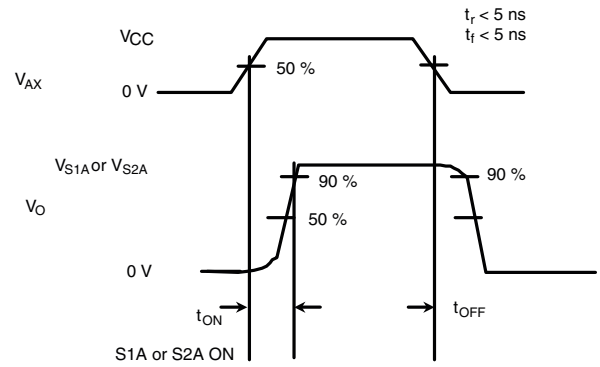
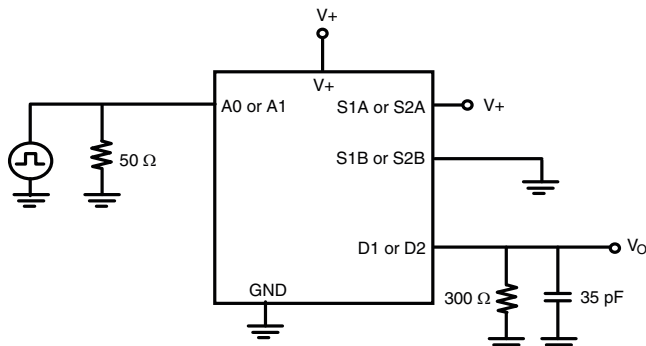


Figure 1. Enable Switching Time

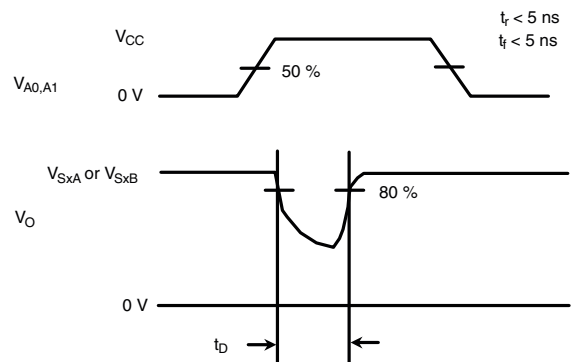
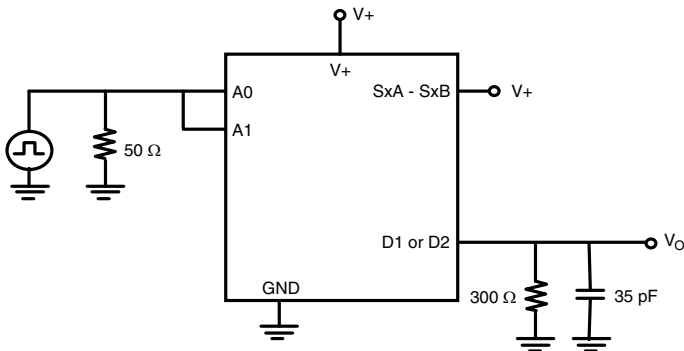


Figure 2. Break-Before-Make

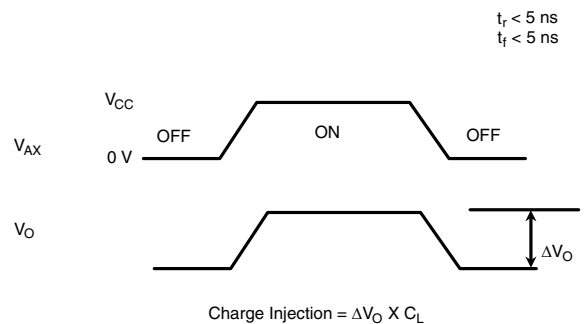
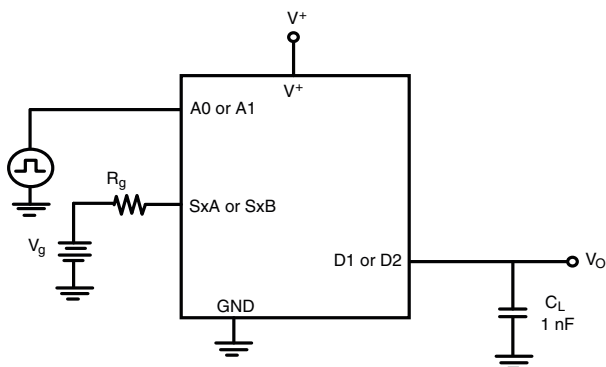
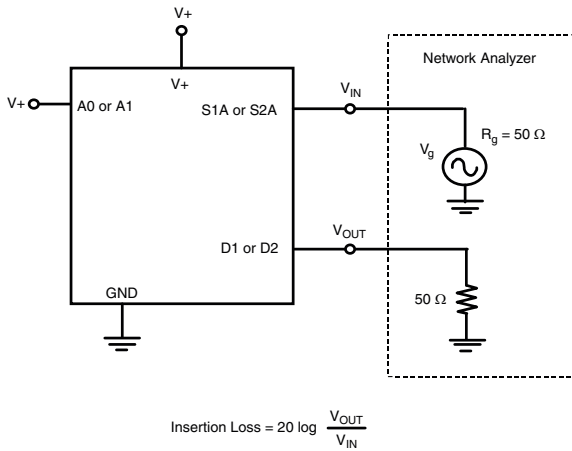


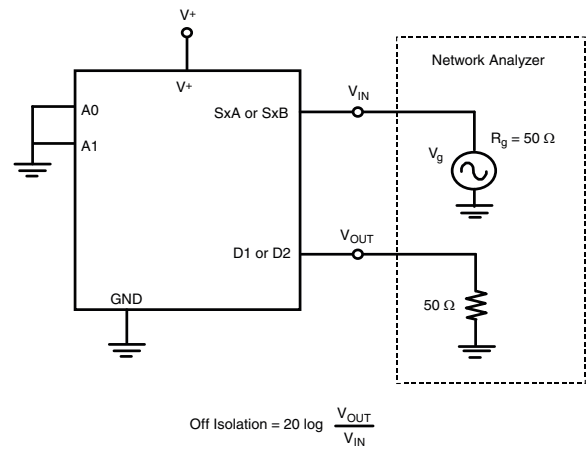
Figure 3. Charge Injection



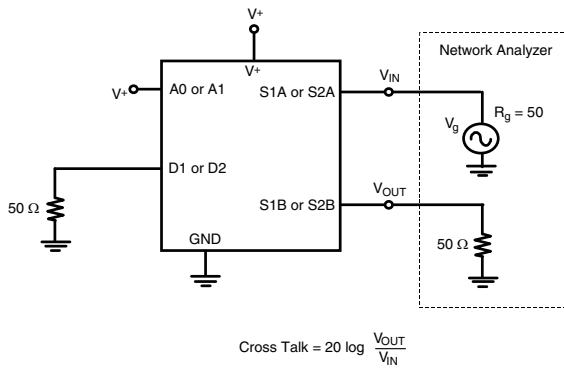
**TEST CIRCUITS**



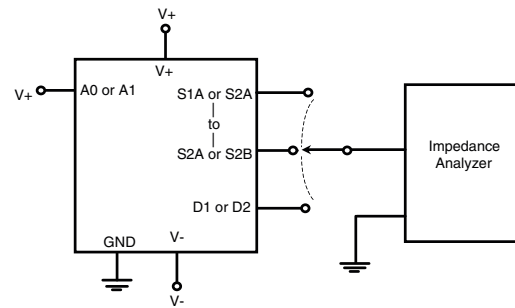
**Figure 4. Insertion Loss**



**Figure 5. Off-Isolation**

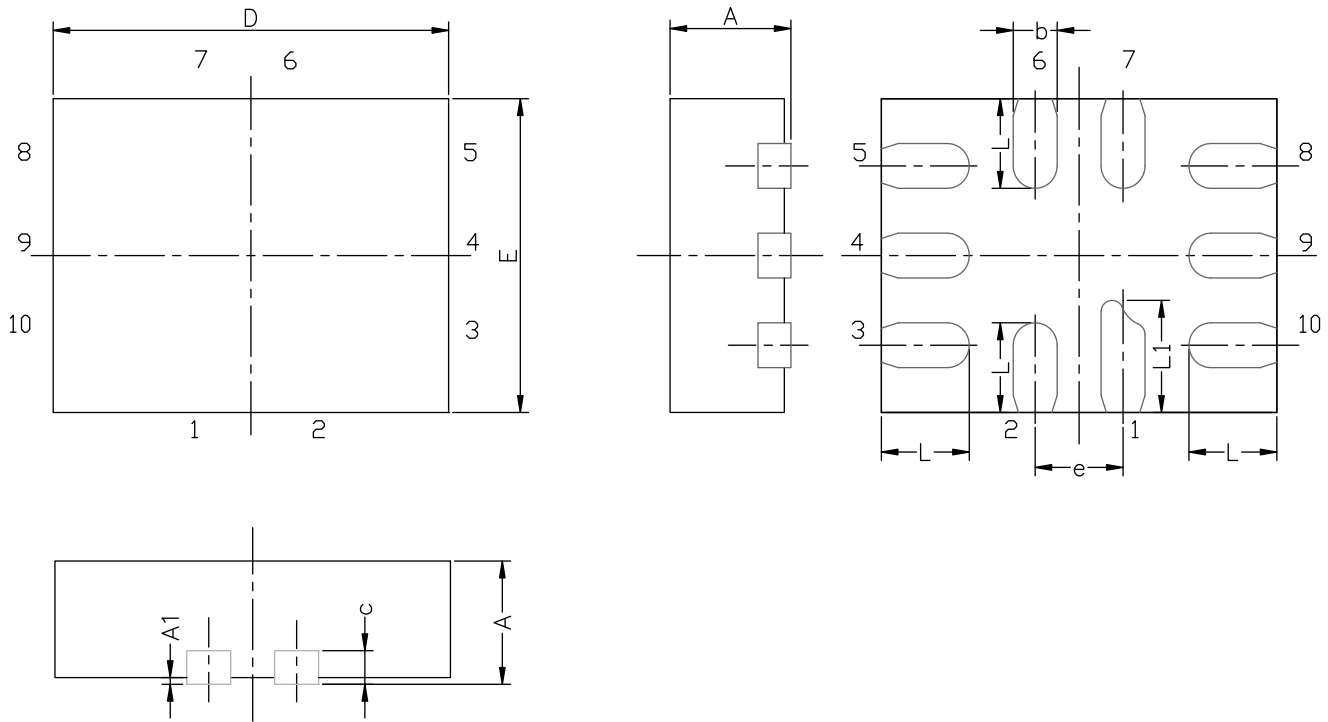


**Figure 6. Crosstalk**



**Figure 7. Source/Drain Capacitance**

Vishay Siliconix maintains worldwide manufacturing capability. Products may be manufactured at one of several qualified locations. Reliability data for Silicon Technology and Package Reliability represent a composite of all qualified locations. For related documents such as package/tape drawings, part marking, and reliability data, see [www.vishay.com/ppg?65159](http://www.vishay.com/ppg?65159).

**MINI QFN-10L CASE OUTLINE**


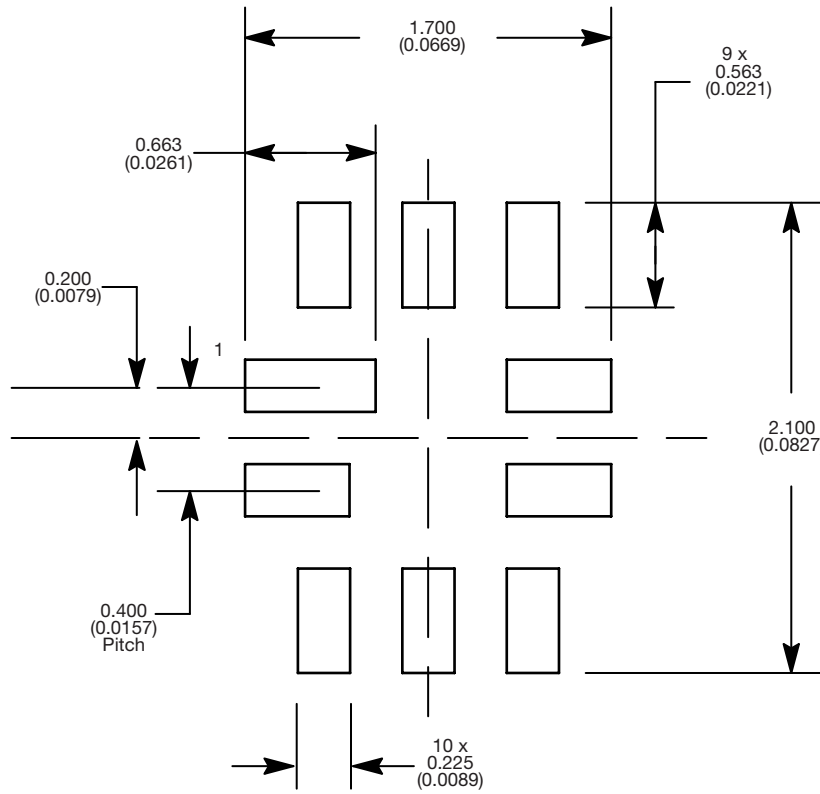
| DIM | MILLIMETERS                       |      |      | INCHES                            |        |        |
|-----|-----------------------------------|------|------|-----------------------------------|--------|--------|
|     | MIN.                              | NAM. | MAX. | MIN.                              | NAM.   | MAX.   |
| A   | 0.45                              | 0.55 | 0.60 | 0.0177                            | 0.0217 | 0.0236 |
| A1  | 0.00                              | -    | 0.05 | 0.000                             | -      | 0.002  |
| b   | 0.15                              | 0.20 | 0.25 | 0.006                             | 0.008  | 0.010  |
| c   | 0.150 or 0.127 REF <sup>(1)</sup> |      |      | 0.006 or 0.005 REF <sup>(1)</sup> |        |        |
| D   | 1.70                              | 1.80 | 1.90 | 0.067                             | 0.071  | 0.075  |
| E   | 1.30                              | 1.40 | 1.50 | 0.051                             | 0.055  | 0.059  |
| e   | 0.40 BSC                          |      |      | 0.016 BSC                         |        |        |
| L   | 0.35                              | 0.40 | 0.45 | 0.014                             | 0.016  | 0.018  |
| L1  | 0.45                              | 0.50 | 0.55 | 0.0177                            | 0.0197 | 0.0217 |

**Note**

<sup>(1)</sup> The dimension depends on the leadframe that assembly house used.

ECN T16-0163-Rev. B, 16-May-16  
DWG: 5957

**RECOMMENDED MINIMUM PADS FOR MINI QFN 10L**



Mounting Footprint  
Dimensions in mm (inch)



## **Disclaimer**

ALL PRODUCT, PRODUCT SPECIFICATIONS AND DATA ARE SUBJECT TO CHANGE WITHOUT NOTICE TO IMPROVE RELIABILITY, FUNCTION OR DESIGN OR OTHERWISE.

Vishay Intertechnology, Inc., its affiliates, agents, and employees, and all persons acting on its or their behalf (collectively, "Vishay"), disclaim any and all liability for any errors, inaccuracies or incompleteness contained in any datasheet or in any other disclosure relating to any product.

Vishay makes no warranty, representation or guarantee regarding the suitability of the products for any particular purpose or the continuing production of any product. To the maximum extent permitted by applicable law, Vishay disclaims (i) any and all liability arising out of the application or use of any product, (ii) any and all liability, including without limitation special, consequential or incidental damages, and (iii) any and all implied warranties, including warranties of fitness for particular purpose, non-infringement and merchantability.

Statements regarding the suitability of products for certain types of applications are based on Vishay's knowledge of typical requirements that are often placed on Vishay products in generic applications. Such statements are not binding statements about the suitability of products for a particular application. It is the customer's responsibility to validate that a particular product with the properties described in the product specification is suitable for use in a particular application. Parameters provided in datasheets and / or specifications may vary in different applications and performance may vary over time. All operating parameters, including typical parameters, must be validated for each customer application by the customer's technical experts. Product specifications do not expand or otherwise modify Vishay's terms and conditions of purchase, including but not limited to the warranty expressed therein.

Except as expressly indicated in writing, Vishay products are not designed for use in medical, life-saving, or life-sustaining applications or for any other application in which the failure of the Vishay product could result in personal injury or death. Customers using or selling Vishay products not expressly indicated for use in such applications do so at their own risk. Please contact authorized Vishay personnel to obtain written terms and conditions regarding products designed for such applications.

No license, express or implied, by estoppel or otherwise, to any intellectual property rights is granted by this document or by any conduct of Vishay. Product names and markings noted herein may be trademarks of their respective owners.