

IRS26320JPbF Functional Block Diagram

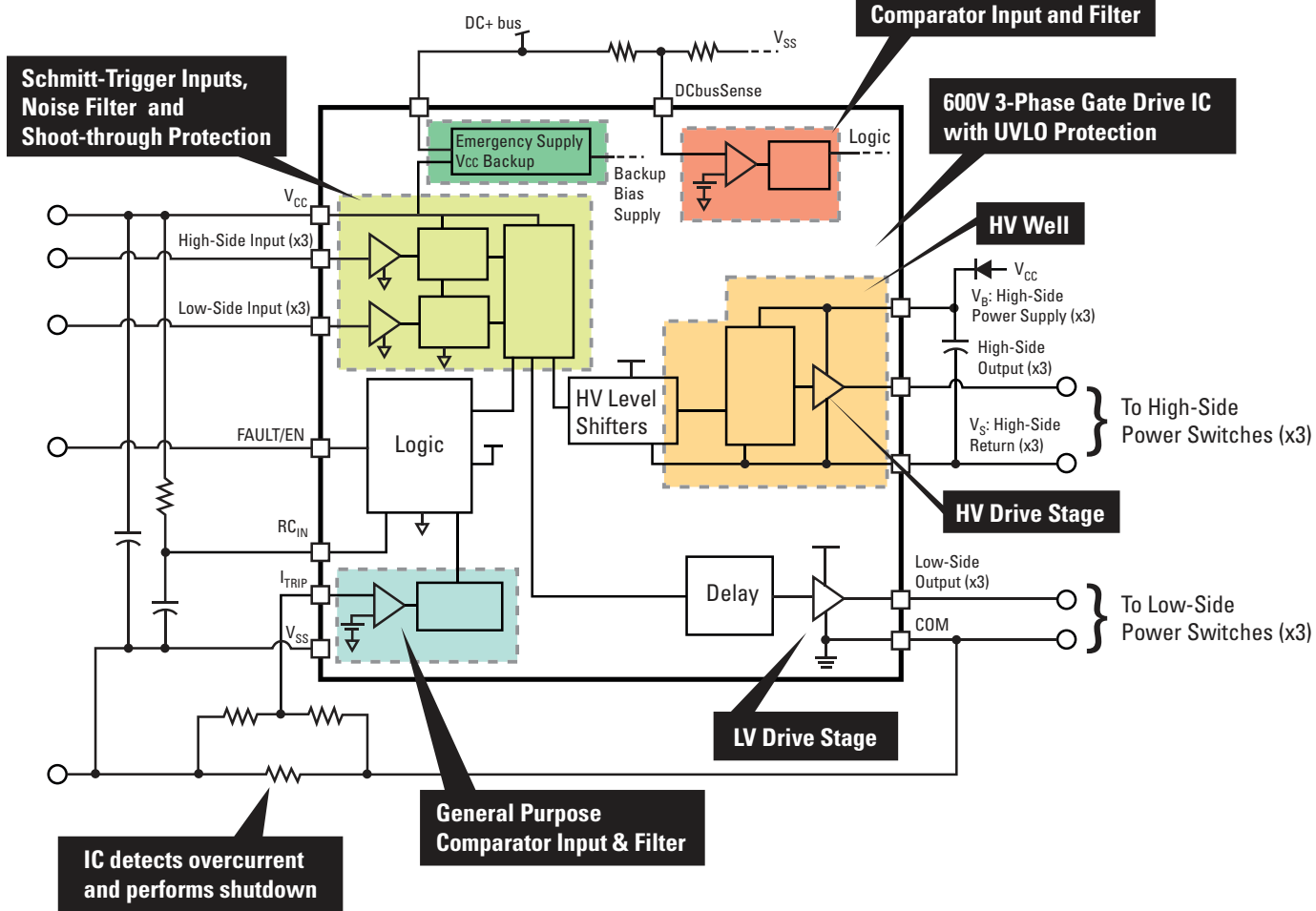

IRS26320JPbF Typical Application Connection

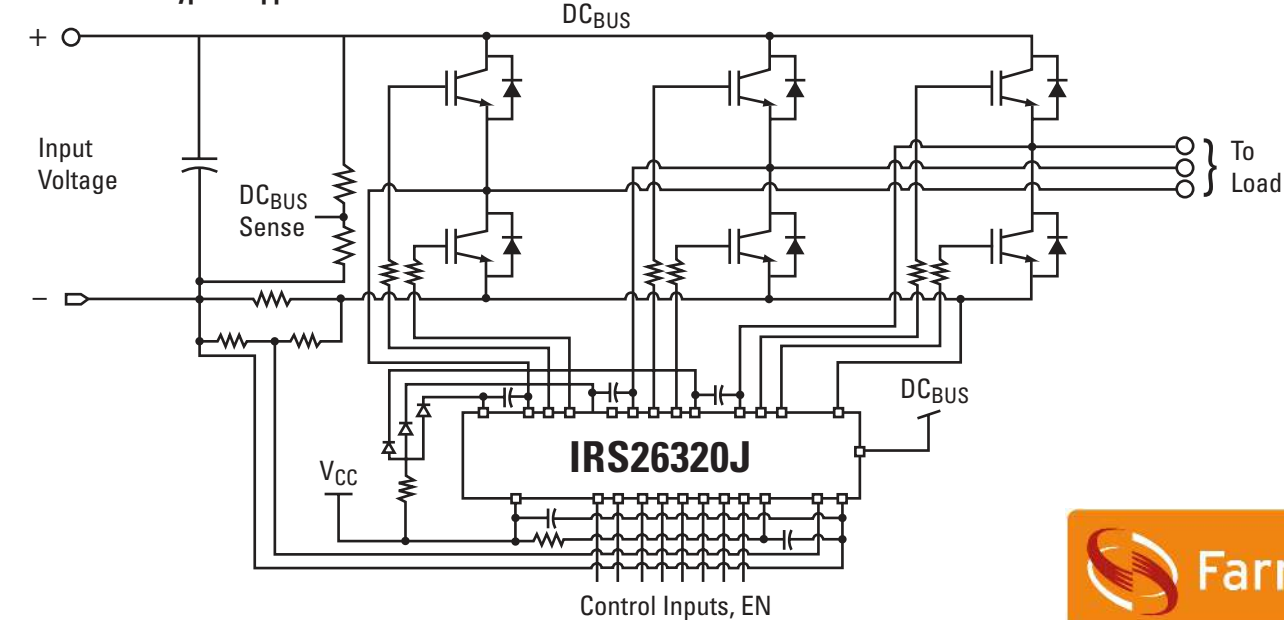

Summary

Topology	3-Phase
V _{OFFSET}	≤ 600V
V _{OUT}	12V - 20V
I _O & I _{O-} (typical)	200mA & 350mA
t _{ON} & t _{OFF} (typical)	530ns & 530ns
Deadtime (typical)	290ns
Package	44-lead PLCC

Features

- Drives up to six IGBT/MOSFET power devices
- Gate drive supplies up to 20V per channel
- Emergency supply backup in case of V_{CC} loss
- DC bus sensing with over-voltage protection
- Over-current protection
- Over-temperature shutdown input
- Advanced input filter
- Integrated deadtime protection
- Shoot-through (cross-conduction) protection
- Under-voltage lockout for V_{CC} and V_{BS}
- Enable/disable input and fault reporting
- Adjustable fault clear timing
- Separate logic and power grounds
- 3.3V input logic compatible
- Tolerant to repetitive negative V_s transient voltage
- Designed for use with bootstrap power supplies
- Matched propagation delays for all channels
- -40°C to 125°C operating range
- RoHS compliant

Typical Applications

- Permanent magnet motor drives for appliances
- Industrial drives
- Micro inverter drives

Typical Connection Diagram

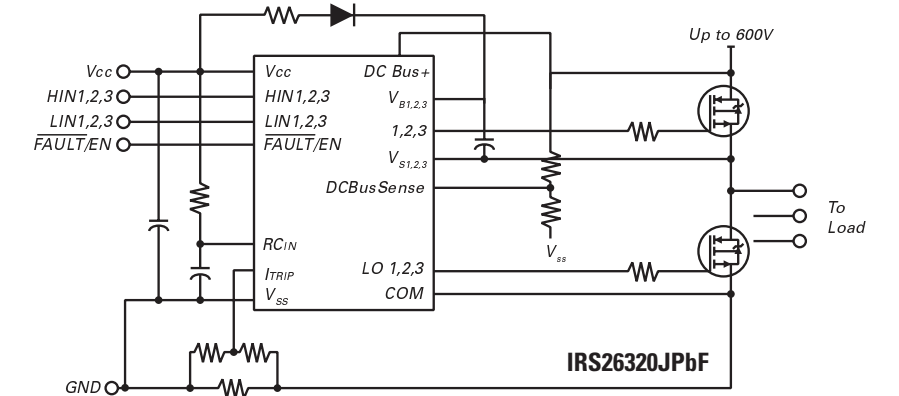

Higher Efficiency

Modern washer manufacturers require state-of-the-art electronic components to deliver more sophisticated features to the end user. The aim is to create a machine that can wash almost all types of fabric with minimum energy, in less time and using less detergent than previous models – without increasing the overall system cost.

Furthermore, government regulations are becoming more and more stringent in terms of efficiency and safety. In the near future, a new energy labeling scheme may be introduced in Europe – and the only way to achieve the highest class label will be to equip the washer with a three-phase permanent magnet (PM) motor.

The IRS26320JPbF from International Rectifier is a high-voltage, high speed power MOSFET and IGBT driver with three independent high- and low-side referenced output channels for three-phase inverters driving PM motors in washers. The motor is enabled to deliver high torque at low speed (during washing) and reach high speed with low torque demand (during spinning). This highly accurate torque and speed control delivers an efficient washing cycle while reducing the motor flux to enable a high spinning speed that helps deliver a more efficient drying function in compliance with safety regulations.

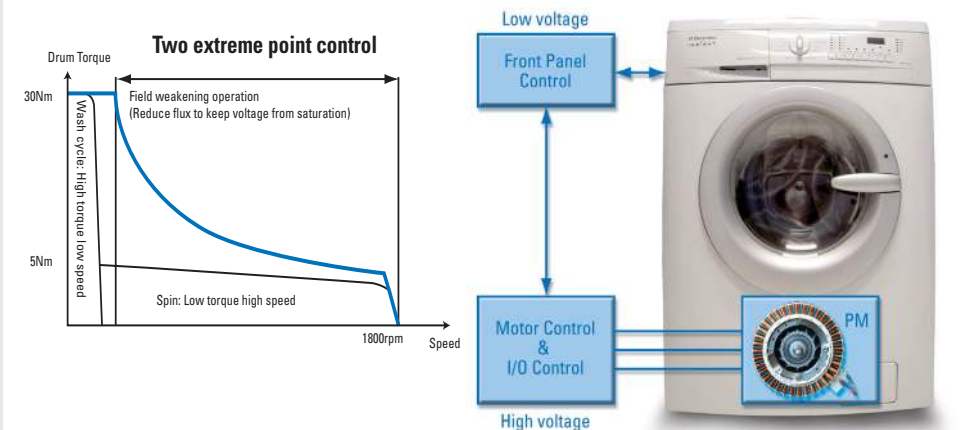

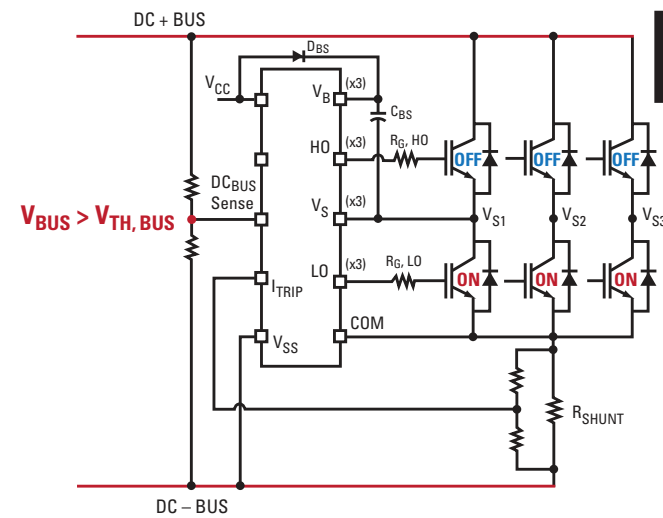

DC Bus over-voltage protection scheme in IRS26320J

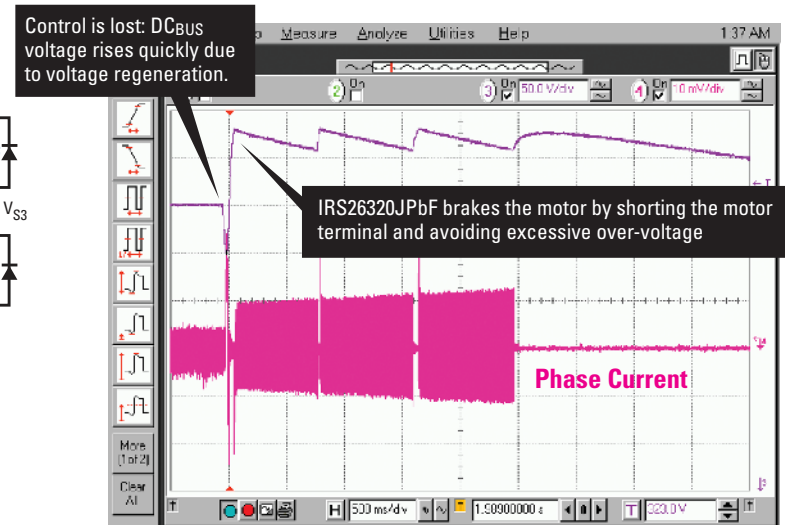

Greater Safety

Safety regulations enforced by law require that every appliance must meet precise international rules. Every appliance must include safety protection circuits either in hardware or in software that avoid hazards to the end user in case of failure of any of the components in the machine. By law, every circuit that implements a protective function must be certified by an internationally recognized institute.

Washers equipped with PM motors present a new challenge to washer manufacturers, because, while in spinning mode, the motor itself can become dangerous in the event that control is lost. To reach the necessary high speed during spinning, the motor must be de-fluxed in real-time fashion. This artificial de-fluxing prevents the motor from generating a significant voltage.

Problems arise if, in the event of controller failure, the motor is left rotating without controlling the applied voltage to it. The motor will then act as a dynamo, generating a high voltage (above 1000V) that can create a fire hazard in the electronics.

The IRS26320JPbF from International Rectifier has been designed with a specific hardware safety function that can override the controller commands and brake the PM motor (by shorting its terminals) until a safe low speed is reached, thus avoiding high-voltage generation. The IRS26320JPbF continuously senses the DC Bus through an external resistor divider and, if a critical voltage is reached, the IRS26320JPbF successfully brakes the motor by shorting the terminal through low-side switches.

Competing solutions require an added external circuit to perform the same function as the IRS26320JPbF. This function is mandatory because it is required for safety purposes. Another important feature of the IRS26320JPbF is an emergency supply backup in case of Vcc loss. If the application power supply fails during field weakening operation, the Vcc may disappear

leaving the inverter totally uncontrolled. This can be a serious fire hazard. The IRS26320JPbF includes a unique emergency backup circuitry that can self-bias the HVIC from the DC Bus and engage a Zero Vector Brake function to coast stop the motor safely. The IRS26320JPbF also embeds other important protection features that are used for safety reasons: anti-shoot through, over-current protection, under-voltage lockout and thermal shutdown input.

Increased Reliability

The IRS26320JPbF from International Rectifier is part of the company's latest family of gate drivers designed to be the most rugged in the market for hard switching environments such as motor control circuits. A typical problem in voltage source inverters with inductive loads (as in the motor control domain) is that the hard switching generates negative voltage spikes whose amplitude and duration depend on the switches and on the layout of the application PCB. Each of these spikes occurs at PWM frequency, so in some operating conditions, they can occur 16000 times per second. In the IRS26320JPbF datasheet, the Safe Operating Area for this HVIC under these conditions is specified.

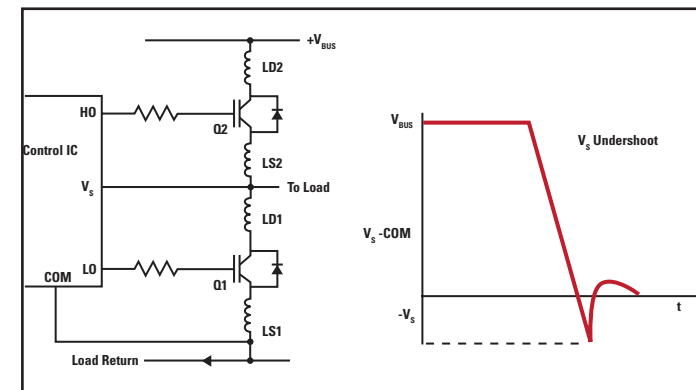

Tolerant to negative transient voltage

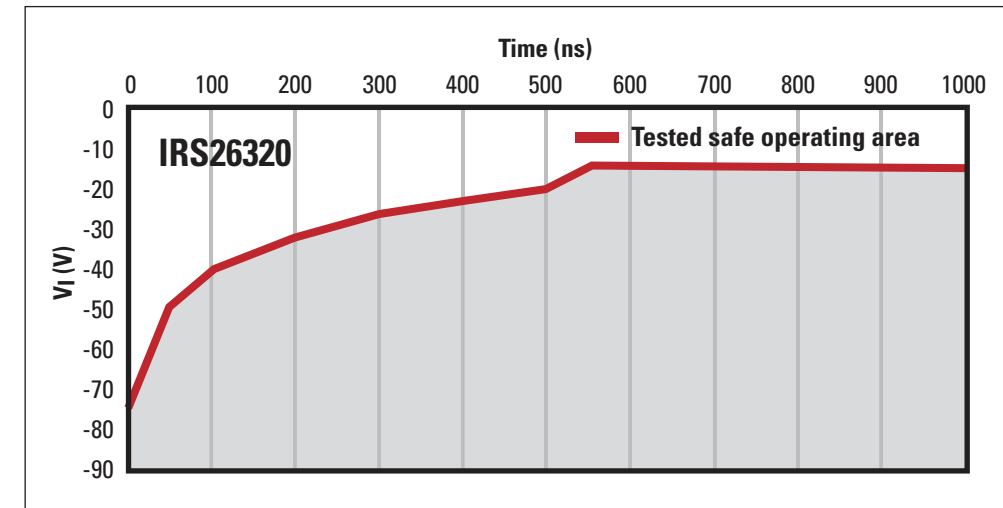

IRS26320JPbF Safe Operating Area under repetitive negative spikes

Overall Benefits

- Reduced component count because the high-voltage clamping diodes used in other solutions are no longer necessary
- Fewer field returns because the robust IR HVIC does not fail in an unpredictable manner unlike other solutions

Input filters have been re-designed to avoid small pulse commands reaching the gates of the switches in the inverter. This is one of the sources of problems in the field and usually it is difficult to detect. The typical effect is that sometimes inverters return from the field damaged with one destroyed leg without an apparent root cause. The IRS26320JPbF embeds filters that solve this issue.

In addition to improved filtering techniques, the IRS26320PbF also guarantees outstanding matching in propagation time on all channels as well as dead-time automatically inserted when external dead-time is lower than a minimum safe limit.

Cost-effectiveness

While including all features in the design of the new rugged family of motion gate drivers, International Rectifier considered the overall system cost requirements of its customers. Therefore, the IRS26320JPbF includes many features that are required in modern applications while keeping external component count to a minimum. With fewer components and field returns, the overall system cost is lower.

Advanced Input Filtering in IRS26320J

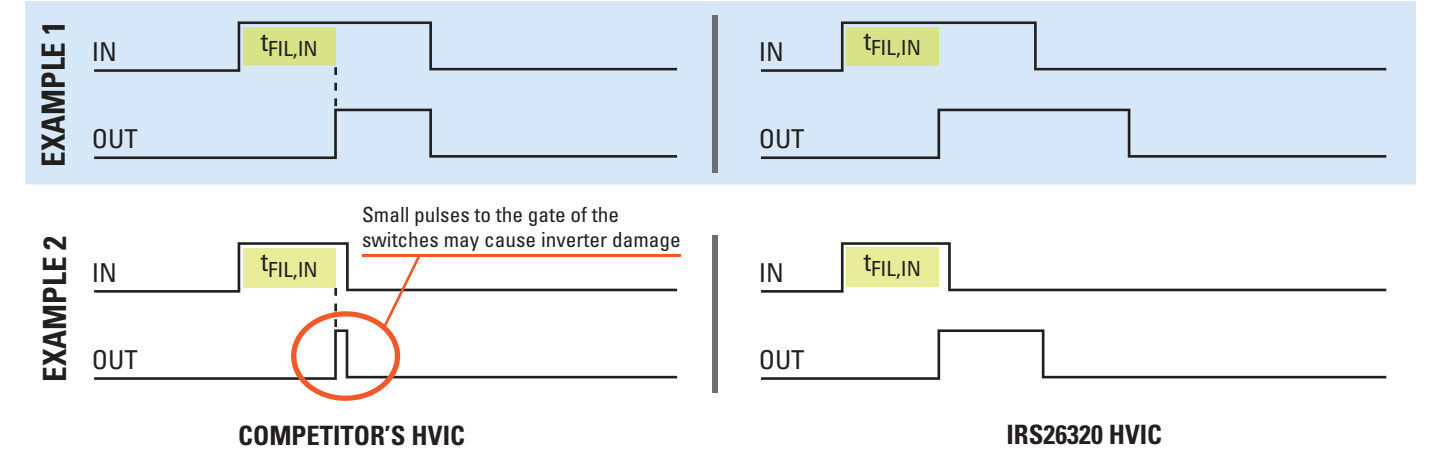

MT	T _{ON} , T _{OFF} matching time (on all six channels)	50ns Max
MDT	DT matching (HIN ->LO & LO->HIN on all channels)	60ns Max
PM	Pulse width distortion	75ns Max

Outstanding deadtime and delay matching in IRS26320J along with low pulse width distortion