

CC900F TYPE 12 COMPACT CABINET COOLER AIR-TO-AIR FLUSH-MOUNT MODEL

Model	Weight	Rating @ 20°C ΔT BTU / hr	Amps Current Draw at 115 volts AC	Fan Size	Dimensions-Inches (H x W x D)
CC900F	16 lbs	4,500	0.6	2 x 6"	15 x 13-7/8 x 7-7/8

Efficiency: 66.0 Watts / °C ΔT based on average internal cabinet temperature.

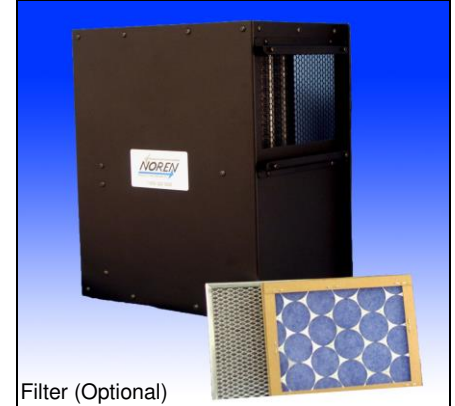
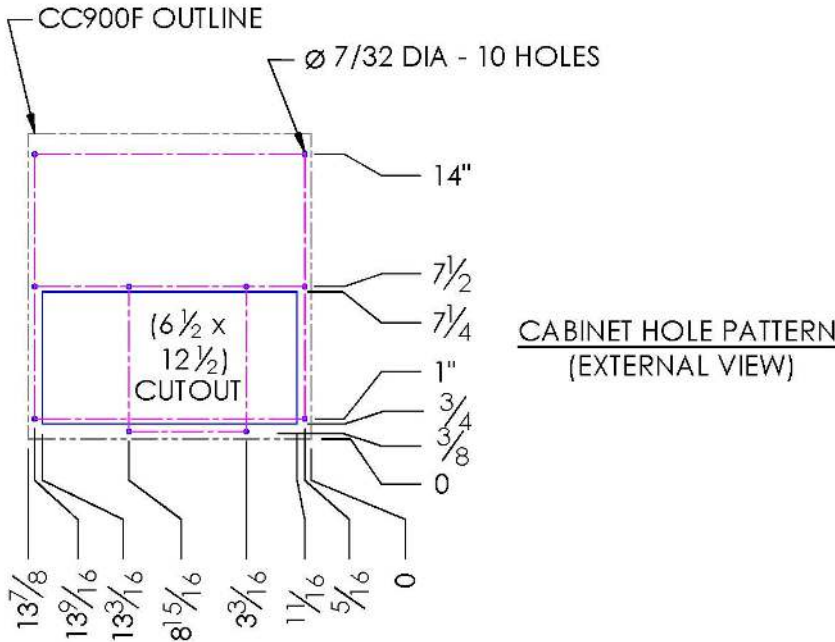
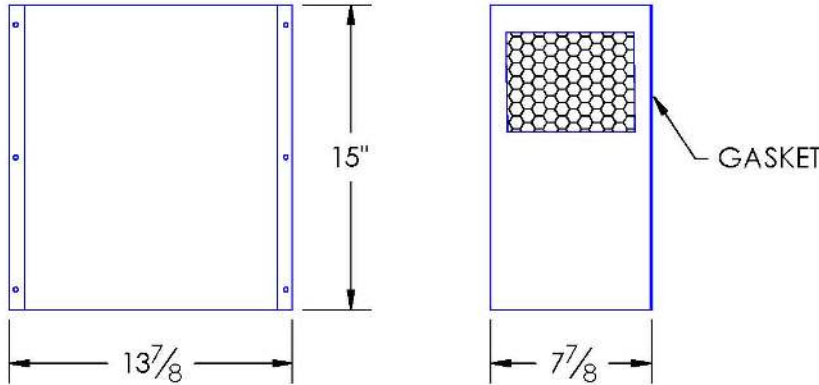

SPECIFICATIONS

1. UL Listed for TYPE 12 environments.
2. CC900F Rated cooling: 1,320 Watts at 20°C ΔT (66.0W/°C, mounted to an uninsulated 72" X 36" X 24" Cabinet)
3. Designed for surface mounting on outside of cabinet.
4. Housing is aluminum (color is black). Stainless steel is available.
5. Equipped with mounting gasket to maintain air tight seal.
6. Internal 6-ft. power cord with 3-prong plug is standard for AC powered units.
7. Available with VAC (115 & 230) and VDC (12, 24, & 48) fans. DC powered units include junction box, consult website.
8. Unit may be mounted vertically (as shown) or horizontally.
9. Optional: inlet air-filter kit available upon request.
10. For design, quote, and sizing assistance: call (866) 936-6736.

Subject to change without notice.



NOREN 1010 O'Brien Drive
Menlo Park, CA 94025
650.322.9500
norenproducts.com

CC900F TYPE 12

CCS-PBD-7.2.2-883352-B