

THIS DRAWING IS UNPUBLISHED. RELEASED FOR PUBLICATION
 © COPYRIGHT - By - ALL RIGHTS RESERVED.

LOC	DIST	REVISIONS					
GP	00	P	LTR	DESCRIPTION	DATE	DWN	APVD
		K		REVISED PER ECO-11-006478	30MAR2011	CJV	CWR

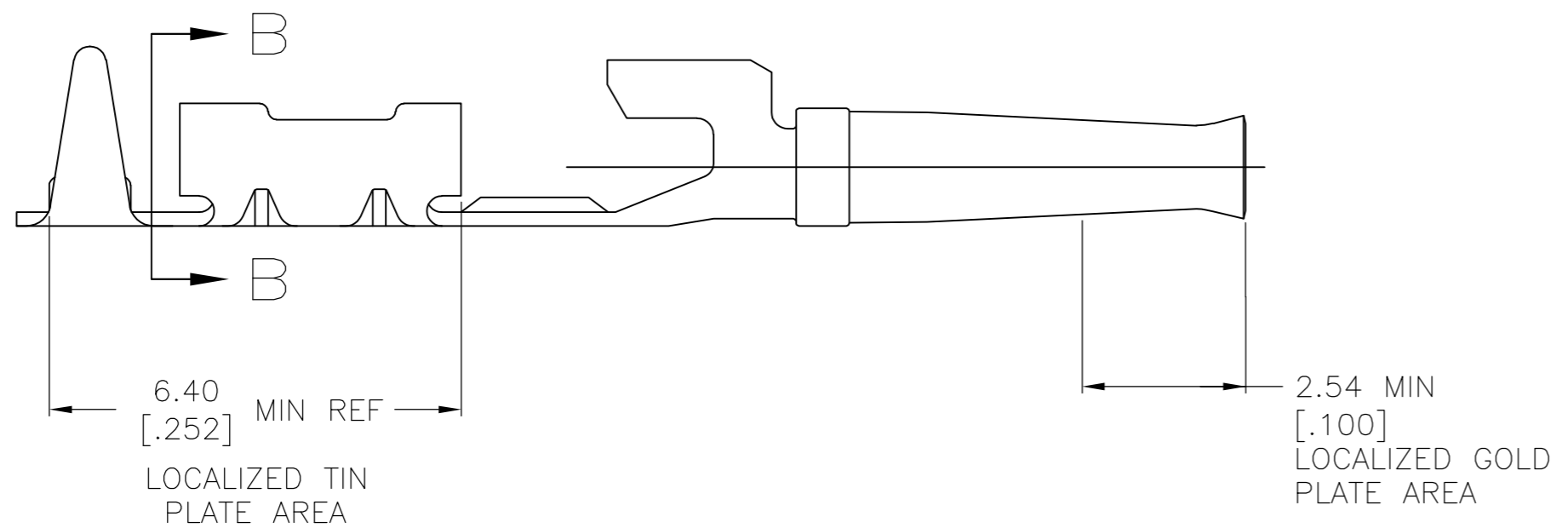
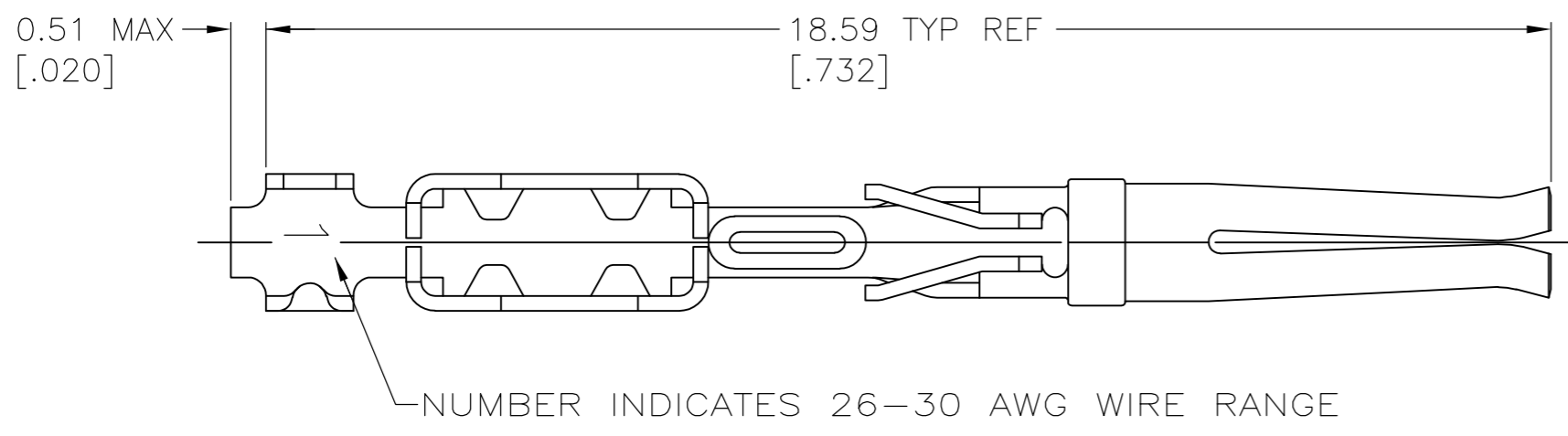

SECTION B-B

- 1 GOLD PLATING PER MIL-G-45204, TIN PLATING PER MIL-T-10727, NICKEL PLATING PER QQ-N-290.
- 2 0.76µm [.000030] MIN GOLD IN LOCALIZED GOLD PLATE AREA, 2.54µm [.000100] MIN BRIGHT TIN OR BRIGHT TIN-LEAD IN MIN LOCALIZED TIN PLATE AREA, ALL OVER 0.76µm [.000030] MIN NICKEL.
- 3 GOLD FLASH IN LOCALIZED GOLD PLATE AREA, 2.54µm [.000100] MIN BRIGHT TIN OR BRIGHT TIN-LEAD IN MIN LOCALIZED TIN PLATE AREA, ALL OVER 0.76µm [.000030] MIN NICKEL.
- 4. MAX INSULATION OD = .060.
- 5 0.76µm [.000030] MIN GOLD IN LOCALIZED GOLD PLATE AREA, 2.54µm [.000100] MIN MATTE TIN IN MIN LOCALIZED TIN PLATE AREA, ALL OVER 0.76µm [.000030] MIN NICKEL.

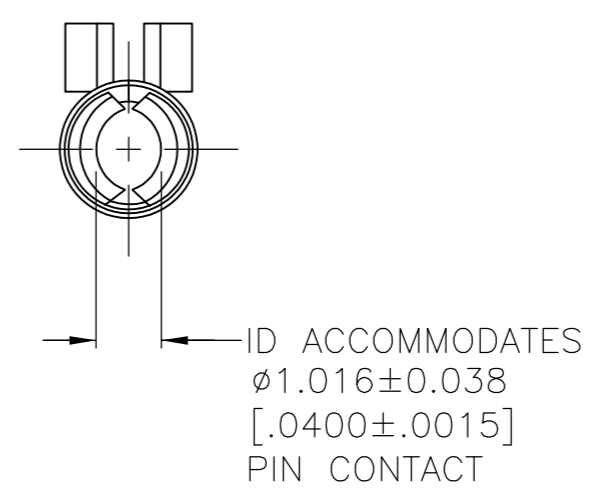

OBSOLETE	5	745931-8
	3	745931-5
	2	745931-3
	FINISH	PART NUMBER

THIS DRAWING IS A CONTROLLED DOCUMENT.		DWN C. RICHARD 03/19/90	TE Connectivity	
DIMENSIONS: INCHES		CHK W. LENKER 3-22-90	CONTACT SOCKET, MASS TERMINATION, #26-30, HDE-20, AMPLIMITE	
TOLERANCES UNLESS OTHERWISE SPECIFIED:		APVD -	NAME	
0 PLC	± -	PRODUCT SPEC	SIZE	CAGE CODE
1 PLC	± -	APPLICATION SPEC	A2	00779
2 PLC	± 0.13 [.005]		DRAWING NO	C=745931
3 PLC	± -		RESTRICTED TO	
4 PLC	± -			
ANGLES	± -	WEIGHT		
MATERIAL PHOSPHOR BRONZE PER QQ-B-750	FINISH 1	CUSTOMER DRAWING	SCALE 10:1	SHEET 1 of 1