

Synchronous Buck Regulator Controller

General Description

The LM2635 is a high speed controller designed specifically for use in synchronous DC/DC buck converters for the Pentium™ II or Deschutes microprocessor. A 5-bit DAC accepts the VID code directly from the CPU and adjusts the output voltage from 1.8V to 3.5V. It provides the power good, over-voltage protection, and output enable features as required by Intel VRM specifications. Current limiting is achieved by monitoring the voltage drop across the r_{DS_ON} of the high side MOSFET, which eliminates an expensive current sense resistor.

The LM2635 employs a fixed-frequency voltage mode PWM architecture. To provide a faster response to a large and fast load transient, two ultra-fast comparators are built in to monitor the output voltage and override the primary control loop when necessary. The PWM frequency is adjustable from 50 kHz to 1 MHz through an external resistor. The wide range of PWM frequency gives the power supply designer the flexibility to make trade-offs between load transient response performance, MOSFET cost and the overall efficiency. The adaptive non-overlapping MOSFET gate drivers help avoid any potential shoot-through problem while maintaining high efficiency. BiCMOS gate drivers with rail-to-rail swing ensure that no spurious turn-on occur. When only 5V is available, a bootstrap structure can be employed to accommodate an NMOS high side switch. The precision reference trimmed to 2% over

temperature is available externally for use by other regulators. Dynamic positioning of load voltage, which helps cut the number of output capacitors, can also be implemented easily.

Features

- 1.8V to 3.5V 5-bit programmable output voltage
- Synchronous rectification
- Power Good flag and output enable
- Over-voltage protection
- Initial Output Accuracy: 2% over temperature
- Current limit without external sense resistor
- Adaptive non-overlapping MOSFET gate drives
- Adjustable switching frequency: 50 kHz to 1 MHz
- Dynamic output voltage positioning
- 1.256V reference voltage available externally
- Plastic SO-20 package

Applications

- Motherboard power supply/VRM for Cyrix Gxm, Cyrix Gxi, Cyrix MII, Pentium II, Deschutes, Pentium Pro, 6x86 and K6 processors
- 5V to 1.8V–3.5V high current power supplies

Typical Application

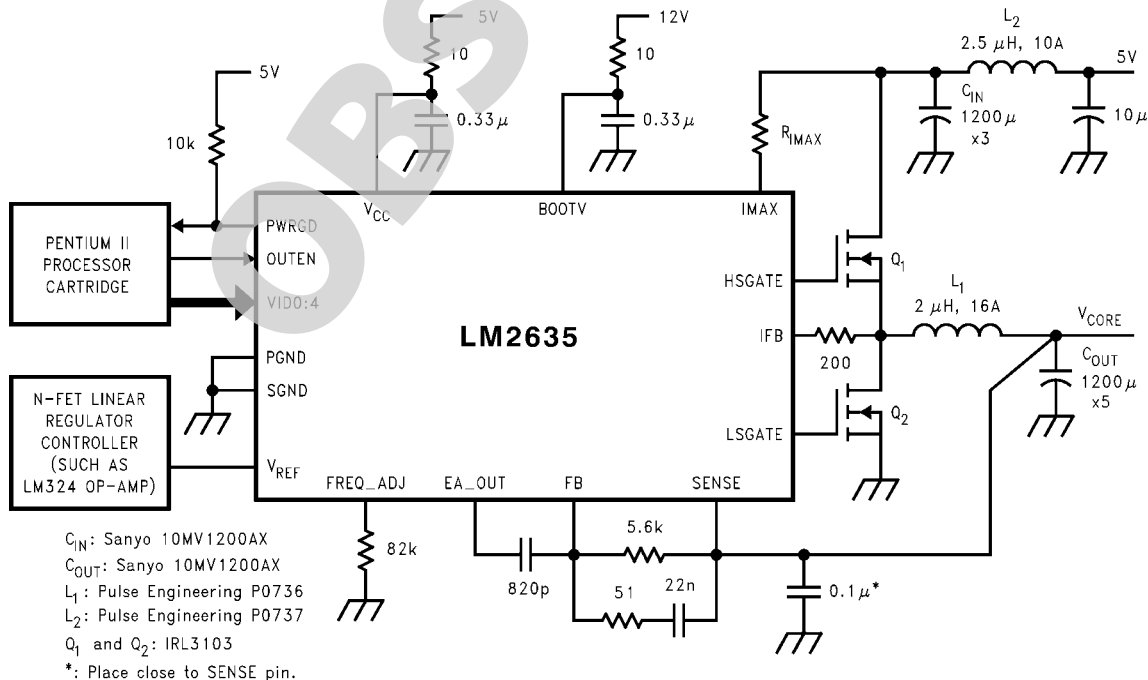
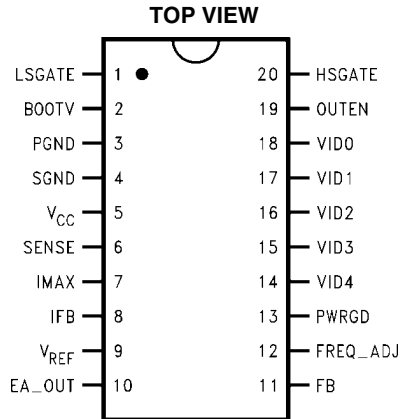

FIGURE 1. 5V to 1.8V–3.5V, 14A Power Supply

Pentium™ is a trademark of Intel Corporation.

Connection Diagram



Plastic SO-20
Order Number LM2635M
See NS Package Number M20B

10011903

Pin Descriptions

LSGATE (Pin 1): Gate drive for the low-side N-channel MOSFET. This signal is interlocked with HSGATE (Pin 20) to avoid a shoot-through problem.

BOOTV (Pin 2): Power supply for high-side N-channel MOSFET gate drive. The voltage should be at least one gate threshold above the converter input voltage to properly operate the high-side N-FET.

PGND (Pin 3): Ground for high current circuitry. It should be connected to system ground.

SGND (Pin 4): Ground for signal level circuitry. It should be connected to system ground.

V_{CC} (Pin 5): Power supply for the controller.

SENSE (Pin 6): Converter output voltage sensing. It provides input for power good, fast dual comparator control loop, and over-voltage protection circuitry. It is recommended that a 0.1 μ F capacitor be connected between this pin and ground to avoid potential noise problems.

IMAX (Pin 7): Current limit threshold setting. It sinks a fixed 180 μ A current. By connecting a resistor between the high side MOSFET drain and this pin, a fixed voltage drop can be

built across the resistor. This voltage drop is compared with the V_{DS} of the high-side N-MOSFET to determine if an over-current condition has occurred.

IFB (Pin 8): High-side N-MOSFET source voltage sensing. This pin is one V_{DS} below drain voltage. When this voltage is lower than that of IMAX pin during the time the high-side FET is on, it means V_{DS} is higher than the preset voltage across the IMAX resistor, which can be interpreted as an over-current condition.

V_{REF} (Pin 9): Bandgap reference voltage. This voltage is mainly for use by other power supplies on the motherboard which need a reference.

EA_OUT (Pin 10): Output of the error amplifier. The voltage level on this pin is compared with an internally generated ramp signal to determine the duty cycle. This pin is necessary for compensating the primary control loop.

FB (Pin 11): Inverting input of the error amplifier. A pin necessary for compensating the control loop.

FREQ_ADJ (Pin 12): Switching frequency adjustment. Switching frequency can be adjusted by changing the grounding resistance on this pin.

PWRGD (Pin 13): Power Good. There are two windows around the DAC output voltage that are associated with PWRGD pin, the $\pm 10\%$ window and the $\pm 8\%$ window. If PWRGD is initially high (open drain state) and output voltage travels out of $\pm 10\%$ window, PWRGD goes to low (low impedance to ground). If PWRGD is initially low and output voltage travels into the $\pm 8\%$ window and has stayed within the window for at least 10 ms, PWRGD goes to high. A PWRGD high means the output voltage is at least within the $\pm 10\%$ window whereas a PWRGD low indicates the output voltage is definitely outside the $\pm 8\%$ window.

VID4:0 (Pins 14, 15, 16, 17, 18): Voltage Identification Code. The five pins accept an open-ground pattern 5-bit binary code from outside the chip (typically from the CPU) for generating the desired output voltage. Each VID pin is internally pulled up to V_{CC} via a 90 μ A current source. Table 1 shows the code table.

OUTEN (Pin 19): Output Enable. The output voltage is disabled when this pin is pulled low. It is internally pulled up to V_{CC} via a 90 μ A current source.

HSGATE (Pin 20): Gate drive for the high-side N-channel MOSFET. This signal is interlocked with LSGATE (Pin 1) to avoid a shoot-through problem.

TABLE 1. VID Code and DAC Output

V _{ID4}	V _{ID3}	V _{ID2}	V _{ID1}	V _{ID0}	Rated Output Voltage (V)
0	1	1	1	1	(#) (1.30)
0	1	1	1	0	(#) (1.35)
0	1	1	0	1	(#) (1.40)
0	1	1	0	0	(#) (1.45)
0	1	0	1	1	(#) (1.50)
0	1	0	1	0	(#) (1.55)
0	1	0	0	1	(#) (1.60)
0	1	0	0	0	(#) (1.65)
0	0	1	1	1	(#) (1.70)
0	0	1	1	0	(#) (1.75)
0	0	1	0	1	1.80
0	0	1	0	0	1.85
0	0	0	1	1	1.90
0	0	0	1	0	1.95
0	0	0	0	1	2.00
0	0	0	0	0	2.05
1	1	1	1	1	(shutdown)
1	1	1	1	0	2.1
1	1	1	0	1	2.2
1	1	1	0	0	2.3
1	1	0	1	1	2.4
1	1	0	1	0	2.5
1	1	0	0	1	2.6
1	1	0	0	0	2.7
1	0	1	1	1	2.8
1	0	1	1	0	2.9
1	0	1	0	1	3.0
1	0	1	0	0	3.1
1	0	0	1	1	3.2
1	0	0	1	0	3.3
1	0	0	0	1	3.4
1	0	0	0	0	3.5

#: These voltages are disabled, can be enabled upon request.

Absolute Maximum Ratings (Note 1)

If Military/Aerospace specified devices are required, please contact the National Semiconductor Sales Office/ Distributors for availability and specifications.

(All voltages are referenced to the PGND and SGND pins.)

V_{CC}	7V
BOOTV	15V
Junction Temperature	150°C
DC Power Dissipation (Note 2)	1.42W
Storage Temperature	-65°C to +150°C

Soldering Time, Temperature

Wave (4 seconds) 260°C

Infrared (10 seconds) 240°C

Vapor Phase (75 seconds) 219°C

ESD Susceptibility (Note 3) 2 kV

Recommended Operating Conditions (Note 1)

Supply Voltage Range (V_{CC}) 4.5V to 5.5V

Junction Temperature Range 0°C to +125°C

Electrical Characteristics

$V_{CC} = 5V$ unless otherwise indicated under the **Conditions** column. Typicals and limits appearing in plain type apply for $T_A = T_J = +25^\circ\text{C}$. Limits appearing in **boldface** type apply over 0°C to $+70^\circ\text{C}$.

Symbol	Parameter	Conditions	Min	Typ	Max	Units
V_{BOOTV}	FET Driver Supply Voltage				15	V
V_{DACOUT}	5-Bit DAC Output Voltage	VID4:0=00101	1.773	1.809	1.845	V
		VID4:0=00001	1.969	2.009	2.049	
		VID4:0=11101	2.165	2.209	2.253	
		VID4:0=10111	2.753	2.809	2.865	
ΔV_{OUT}	DC Load Regulation	$I_{OUT}=0$ to 14A Figure 2		-5		mV
	DC Line Regulation	$V_{IN}=4.75V$ to 5.25V Figure 2		1		
G_{EA}	Error Amplifier DC Gain			85		dB
SR_{EA}	Error Amplifier Slew Rate			6		V/ μs
BW_{EA}	Error Amplifier Unity Gain Bandwidth			5		MHz
I_{Q_VCC}	Operating V_{CC} Current	OUTEN= $V_{CC}=5V$, VID=10111	1.5	2.5	4	mA
	Shutdown V_{CC} Current	OUTEN Floating, VID0:4 Floating	1	1.5	3	
I_{Q_BOOTV}	BOOTV Pin Quiescent Current	BOOTV=12V, OUTEN=0, VID0:4 Floating		4		μA
D_{MAX}	Maximum Duty Cycle			90		%
D_{MIN}	Minimum Duty Cycle			0		%
R_{SENSE}	SENSE Pin Resistance to Ground		7	11.5	16	k Ω
R_{DS_SRC}	FET Driver Drain-Source ON Resistance when Sourcing Current	BOOTV=5V		7		Ω
R_{DS_SINK}	FET Driver Drain-Source ON Resistance when Sinking Current	(Independent of BOOTV Voltage)		1.7		Ω
f_{OSC}	Oscillator Frequency	$R_{FA} = 84\text{ k}\Omega$	250	300	350	kHz
		$R_{FA} = 22\text{ k}\Omega$		1000		
		$R_{FA} = 10.5\text{ k}\Omega$		2000		
I_{MAX}	IMAX Pin Sink Current	$V_{IMAX} = 5V$, $V_{IFB} = 6V$, $V_{CC} = 5V$	130	180	230	μA
V_{OUTEN_IH}	OUTEN Pin Input Logic Low to Logic High Trip Point	OUTEN Voltage	3.5	3.0		V
V_{OUTEN_IL}	OUTEN Pin Input Logic High to Logic Low Trip Point	OUTEN Voltage		1.8	1.5	V
V_{REF}	Band Gap Reference	$I_{VREF} = 0\text{ mA}$	1.231	1.256	1.281	V
V_{REF_LOAD}	Reference Voltage at Full Load	$I_{VREF} = 0.5\text{ mA}$, Sourcing	1.229	1.254	1.279	V

Symbol	Parameter	Conditions	Min	Typ	Max	Units
V _{REF_525}	Reference Voltage at High Line	I _{VREF} = 0 mA, V _{CC} = 5.25V	1.232	1.257	1.282	V
V _{REF_475}	Reference Voltage at Low Line	I _{VREF} = 0 mA, V _{CC} = 4.75V	1.230	1.258	1.280	V
ΔV _{REF_LOAD}	Reference Voltage Load Regulation	I _{VREF} = 0.5 mA, Sourcing		-2		mV
ΔV _{REF_LINE}	Reference Voltage Line Regulation	I _{VREF} = 0 mA, V _{CC} Changes from 5.25V to 4.75V		-0.5		mV
V _{SAWL}	Ramp Signal Valley Voltage			1.25		V
V _{SAWH}	Ramp Signal Peak Voltage			3.25		V
V _{PWRBAD_GD}	PWRGD Pin Trip Points (see Pin Description for Pin 13)	% above DAC Output Voltage, when Output Voltage % below DAC Output Voltage, when Output Voltage		10 -10		%
V _{PWRGD_BAD}	PWRGD Pin Trip Points (see Pin Description for Pin 13)	% above DAC Output Voltage, when Output Voltage % below DAC Output Voltage, when Output Voltage		8 -8		%
V _{OVP}	Over-voltage Protection Trip Point	% above DAC Output Voltage		15		%
t _{PWRGD}	Power Good Response Time	V _{SENSE} Rises from 0V to Rated V _{OUT}	2	6	15	μs
t _{PWRBAD}	Power Not Good Response Time	V _{SENSE} Falls from Rated V _{OUT} to 0V	2	6	15	μs
I _{OUTEN}	OUTEN Pin Internal Pull-Up Current		60	90	130	μA
V _{VID_IH}	VID Pins Logic High Trip Point		3.5	3.0		V
V _{VID_IL}	VID Pins Logic Low Trip Point			1.8	1.3	V
I _{VID}	VID0:4 Internal Pull-Up Current		60	90	130	μA
t _{SS}	Soft Start Duration			2048		clock cycles

Note 1: Absolute Maximum Ratings are limits beyond which damage to the device may occur. **Recommended Operating Conditions** are conditions under which the device operates correctly. **Recommended Operating Conditions** do not imply guaranteed performance limits.

Note 2: Maximum allowable DC power dissipation is a function of the maximum junction temperature, T_{JMAX}, the junction-to-ambient thermal resistance, θ_{JA}, and the ambient temperature, T_A. The maximum allowable power dissipation at any ambient temperature is calculated using:

$$P_{MAX} = \frac{T_{JMAX} - T_A}{\theta_{JA}}$$

The junction-to-ambient thermal resistance, θ_{JA}, for LM2635 in the M20B package is 88°C/W.

Note 3: All pins are rated for 2 kV, except for the I_{MAX} pin (Pin 7) which is rated for 1.5 kV.

Block Diagram

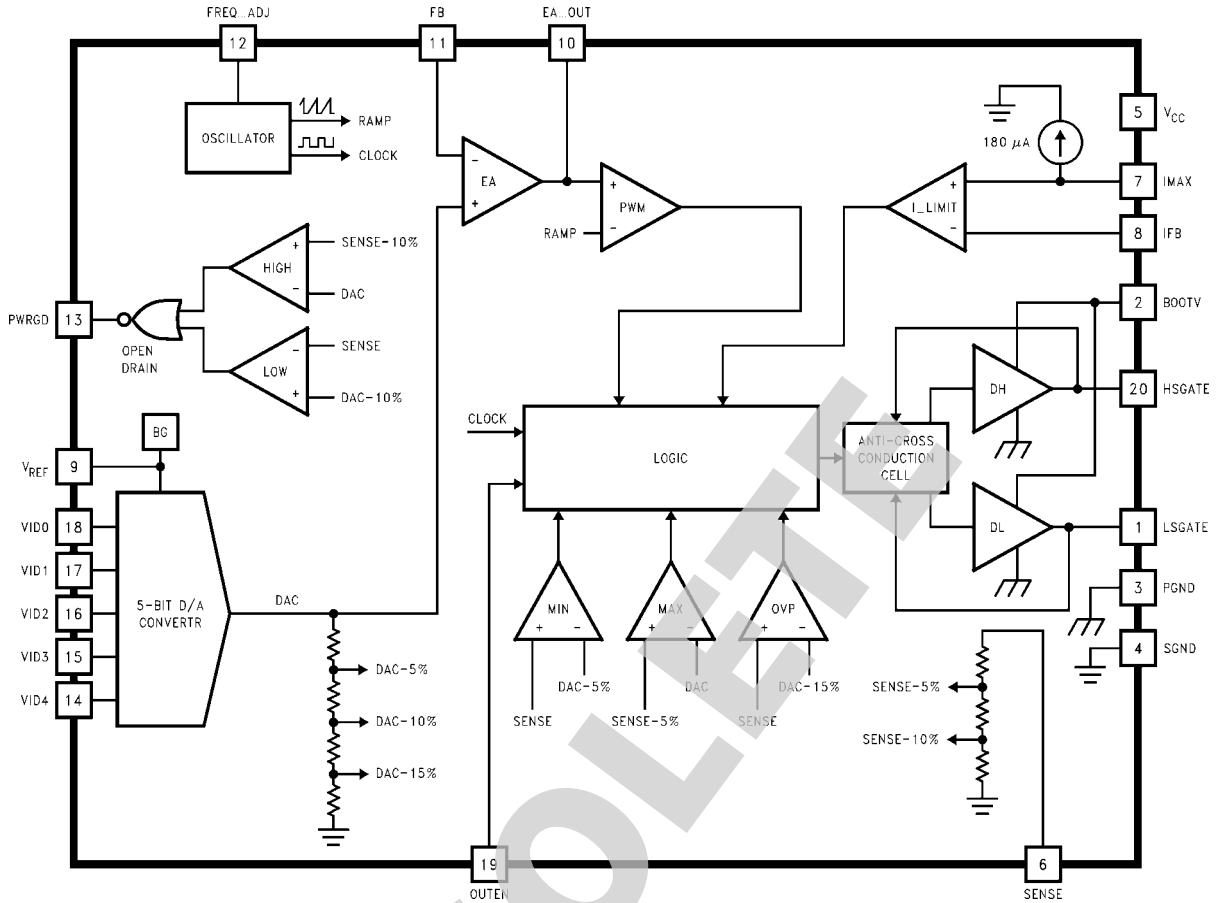

10011902

Test Circuit

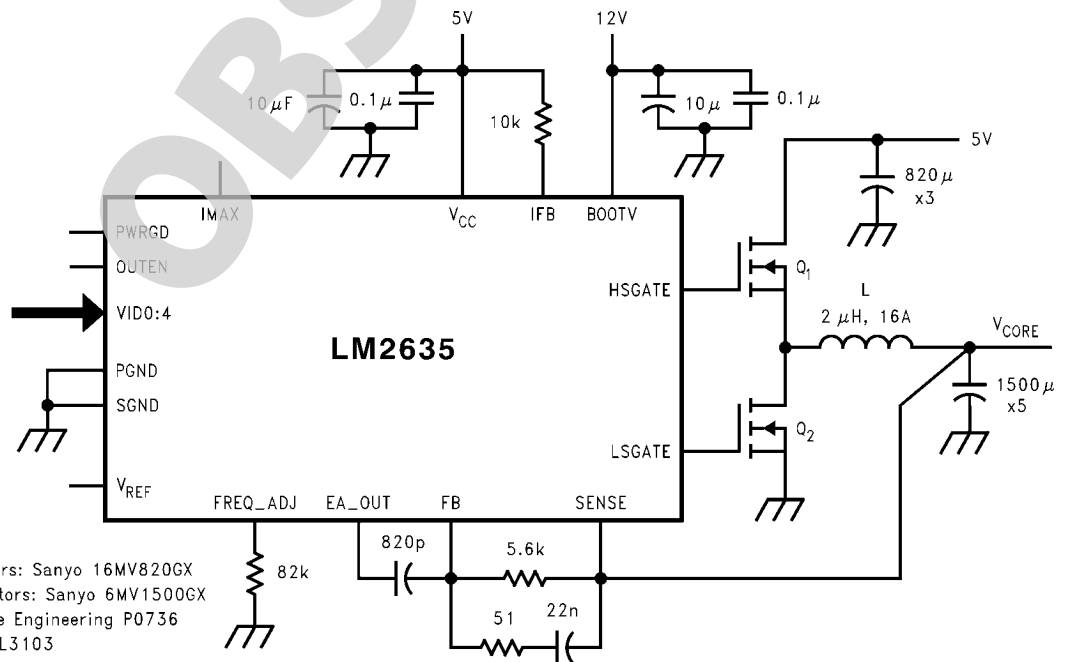

10011904

FIGURE 2.

Applications Information

OVERVIEW

The LM2635 is a high speed synchronous PWM buck regulator controller designed for VRM vendors or motherboard manufacturers who need to build on-board power supplies for Cyrix MII, Pentium II or Deschutes microprocessors. It has a built-in 5-bit DAC to decode the 5-bit word provided by the CPU and supply the corresponding voltage. It also has the power good (PWRGD) and output enable (OUTEN) functions required by the VRM specification. It employs a voltage mode control scheme plus two fast responding comparators to quickly respond to large load transients. It has two fast FET drivers to drive the high-side and low-side NMOS switches of a synchronous buck regulator. The PWM frequency is adjustable from 50 kHz to 1 MHz through an external resistor. Over-voltage protection is achieved by shutting off the high-side driver and turning on the low-side driver 100% of the time. Current limiting is implemented by sensing V_{DS} of the high-side NMOS switch and shutting it off for the present switching cycle when an over current condition is detected. Soft start functionality is realized through an internal digital counter and an internal DAC.

THEORY OF OPERATION

Start Up

When V_{CC} voltage exceeds 4.2V, OUTEN pin is a logic high and the VID code is valid, the soft start circuitry starts to work. The duration of the soft start is determined by an internal digital counter and the switching frequency. During soft start, the output of the error amplifier is allowed to increase gradually. When the counter has counted 2,048 clock cycles, the soft start session ends and the output voltage level of the error amplifier is released and allowed to go to a value that is determined by the feedback loop. PWRGD pin is forced low during soft start and is turned over to output voltage monitoring circuitry after that. Before V_{CC} reaches 4.2V, all internal logic is in a power on reset state and the two FET drivers are disabled.

During normal operation, if V_{CC} voltage drops below 3.8V, the internal circuitry will go into power on reset again. The hysteresis helps decrease the noise sensitivity on the V_{CC} pin. After soft starts ends and during normal operation, if the converter output voltage exceeds 115% of the DAC output voltage, the LM2635 will lock into over voltage protection mode. The high side drive will be disabled, and the low side drive will be high. There are two ways to clear the mode. One is to cycle V_{CC} voltage once. The other is to toggle the OUTEN level. After the over voltage protection mode is cleared, the LM2635 will enter the soft start session and start over.

Normal Operation

During the normal operation mode, the LM2635 regulates the converter output voltage by adjusting the duty ratio. The output voltage is determined by the 5-bit VID code set by the user/load.

The PWM frequency is set by the external resistor between FREQ_ADJ pin and ground. The resistance needed for a desired switching frequency is:

$$R = \frac{25,000}{f(\text{kHz})} \text{ k}\Omega$$

For example, if the desired switching frequency is 300 kHz, the resistance should be around 84 k Ω .

The minimum allowable PWM frequency is 5 kHz.

MOSFET Gate Drive

The LM2635 has two gate drives that are suitable for driving external N-MOSFETs in a synchronous buck topology. The power for the two FET drivers is supplied by the BOOTV pin. This BOOTV voltage needs to be at least one $V_{GS(th)}$ higher than the converter input voltage for the high side FET to be fully turned on. The voltage can be either supplied from a separate source other than the input voltage or can be generated locally by utilizing a charge pump structure. In a typical desktop microprocessor application, if 5V is chosen to be the input voltage, then 12V can be used for the BOOTV. If 12V is not available, a simple charge pump circuitry consisting of a diode and a small capacitor can be used, as shown in Figure 3.

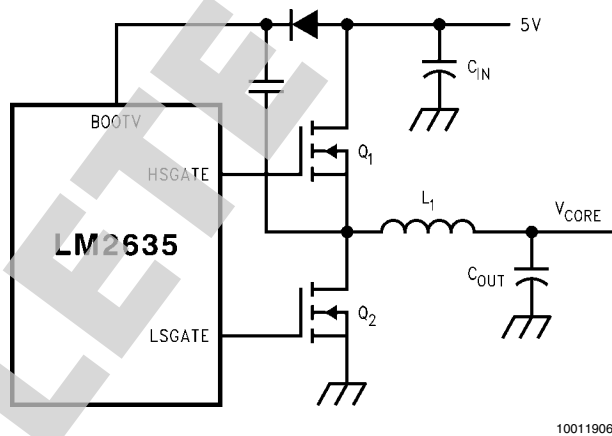

10011906

FIGURE 3. BOOTV Voltage Supplied by a Charge Pump

When the low side FET is on, the charge pump capacitor is charged to near the input voltage through the diode. When low side FET is turned off, the high side FET driver is enabled, and the charge pump capacitor starts to charge the high side FET gate until it is fully on. By this time the high side FET source node will fly to close to input voltage level and the upper node of the capacitor will also fly to one input voltage higher than the input voltage, enabling the high side FET driver to continue working.

For a BOOTV of 12V, the initial gate charging current is typically 2A, and the initial gate discharging current is typically 6A, good for high speed switching.

The LM2635 gate drives are of BiCMOS design. Unlike some other bipolar VRM control ICs, the gate drive has rail-to-rail swing that ensures no spurious turn-on due to capacitive coupling.

Another feature of the FET gate drives is the adaptive non-overlapping mechanism. A gate driver is not turned on until the other is fully off. The dead time in between is typically 20 ns. This avoids the potential shoot-through problem and helps improve efficiency.

Load Transient Response

In a typical modern MPU application such as the Pentium II core voltage power supply, load transient response is a critical issue. The LM2635 utilizes the conventional voltage feedback technology as the primary feedback control method. When the load transient happens, the error in the output voltage level is fed to the error amplifier. The output of the error amplifier is then compared with an internally generated PWM

ramp signal and the result of the comparison is a series of pulses with certain duty ratios. These pulses are used to control the turn-on and turn-off of the MOSFET gate drivers. In this way, the error in the output voltage gets “compensated” or cancelled by the change in the duty ratio of the FET switches. During a large load transient, depending on the compensation design, the change in duty ratio can be as fast as less than one switching cycle. Refer to Design Considerations section for more details.

Besides the usual voltage mode feedback control loop, the LM2635 also has a pair of fast comparators (the MIN and MAX comparators) to help maintain the output voltage during a large and fast load transient. The trip points of the comparators are set to $\pm 5\%$ of the DAC output voltage. When the load transient is so large that the output voltage goes outside the $\pm 5\%$ window, the MIN or MAX comparator will bypass the primary voltage control loop and immediately set the duty ratio to either maximum value or to zero. This provides the fastest possible way to react to such a large load transient in a classical buck converter.

Power Good Signal

The power good signal is used to indicate that the output voltage is within specified range. In the LM2635, the range is set to a $\pm 10\%$ window of the DAC output voltage. During soft start, the power good signal is always low. At the end of the soft start session, the output voltage is checked and the PWRGD pin will be asserted if the voltage is within specified range.

Over Voltage Protection

When the output voltage exceeds 115% of the DAC output voltage after the end of soft start, the LM2635 will enter over voltage protection mode in which it shuts itself down. The upper gate driver is held low while the lower gate driver is held high. PWRGD will be low. For LM2635 to recover from OVP mode, either OUTEN or V_{CC} voltage has to be toggled. Another more subtle way to recover is to float all the VID pins and reapply the correct code.

Current Limit

Current limit is realized by sensing the V_{DS} voltage of the high side MOSFET when it is on. Since the r_{DS_ON} of a MOSFET is a known value, current through the MOSFET can be known by monitoring V_{DS} . The relationship between the three parameters is:

$$I = \frac{V_{DS}}{r_{DS_ON}}$$

To implement the current limit function, an external resistor R_{IMAX} is needed. The resistor should be connected between the drain of the high side MOSFET and the IMAX pin. A constant current of around 180 μA is forced into the IMAX pin and causes a fixed voltage drop across the R_{IMAX} resistor. This voltage drop is then compared with the V_{DS} of the high side MOSFET and if the latter is higher, over current is reached. So the appropriate value of R_{IMAX} for a pre-determined current limit level I_{LIM} can be calculated by the following equation:

$$R_{IMAX} = \frac{r_{DS_ON} \times I_{LIM}}{I_{IMAX}}$$

For example, if we know that the r_{DS_ON} of the MOSFET is 20 $m\Omega$, and the current limit we want to set is 20A, then we should choose the value of R_{IMAX} to be 2.2 $k\Omega$.

To provide the greatest protection over the high side MOSFET, cycle by cycle protection is implemented. The sampling of the V_{DS} starts as early as about 300 ns after the switch is turned on. Whenever an over current condition is detected, the high side switch is immediately turned off and the low side switch turned on, until the next switching cycle comes. The delay of 300 ns is to circumvent switching noise when the MOSFET is first turned on.

DESIGN CONSIDERATIONS

Control Loop Compensation

A switching regulator should be properly compensated to achieve a stable condition. For a synchronous buck regulator that needs to meet stringent load transient requirement such as a Pentium II MPU core voltage supply, a simple 2-pole-1-zero compensation network should suffice, such as the one shown in Figure 4 (C_1 , C_2 , R_1 and R_2). This is because the ESR zero of the typical output capacitors is low enough to make the control-to-output transfer function a single-pole-roll-off.

As an example, let us figure out the values of the compensation network components in Figure 4. Assume the following parameters: $R = 20\Omega$, $R_L = 20\ m\Omega$, $R_C = 9\ m\Omega$, $L = 2\ \mu H$, $C = 7.5\ mF$, $V_{IN} = 5V$, $V_m = 2V$ and switching frequency = 300 kH . These parameters are based on the typical application in Figure 1. Notice R_L is the sum of the inductor DC resistance and the on resistance of the MOSFETs.

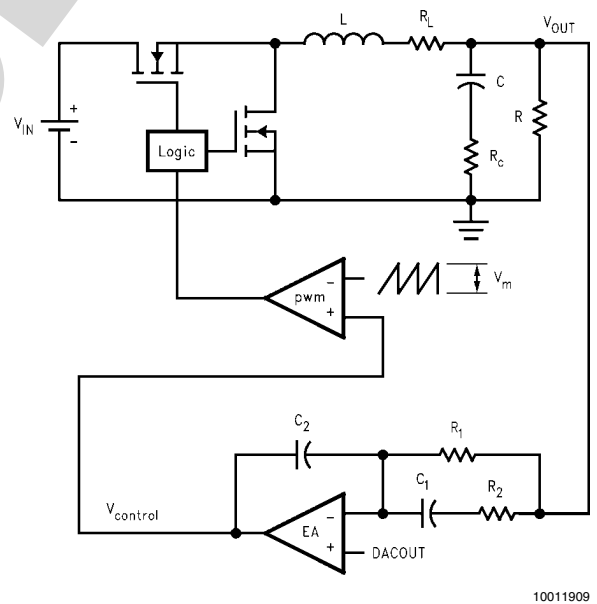

FIGURE 4. Buck Converter from a Control Point of View

The control-to-output transfer function is

$$TF1 = \frac{\tilde{V}_{OUT}}{\tilde{V}_{control}} = \frac{R \cdot V_{IN} \cdot (SC_{RC} + 1)}{S^2 LC (R + R_c) + S[L + R_L C(R + R_c) + RR_c C] + R + R_L} \cdot \frac{1}{V_m}$$

The ESR zero frequency is:

$$f_{ESR} = \frac{1}{2\pi CR_c} = 2.36 \text{ kHz}$$

The power stage double pole frequency is:

$$f_{2P} = \frac{1}{2\pi} \sqrt{\frac{R + R_L}{LC(R + R_c)}} = 1.3 \text{ kHz}$$

The corresponding Bode plots are shown in Figure 5.

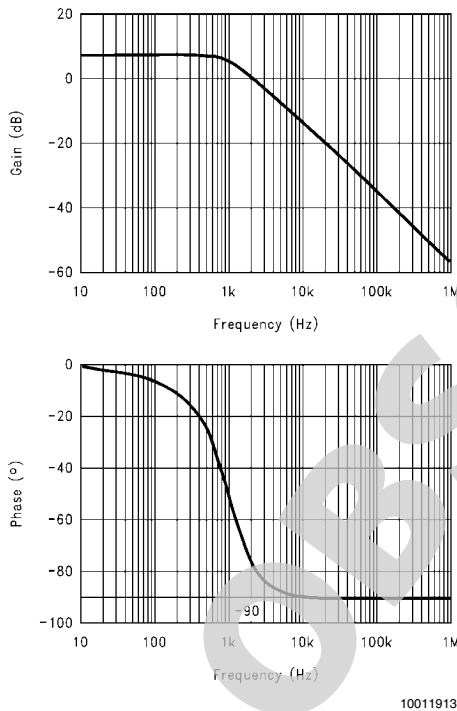

FIGURE 5. Control-to-Output Bode Plots

Since the ESR zero frequency is so low, it effectively cancels the phase shift from one of the power stage poles. This limits the total phase shift to 90%.

Although this regulator design is stable (phase shift is <90° when gain = 0dB), it needs compensation to improve the DC gain and cut off frequency (0dB frequency). Otherwise, the low DC gain may cause a poor line regulation, and the low cutoff frequency will hurt transient response performance.

The transfer function for the 2-pole-1-zero compensation network shown in Figure 4 is:

$$TF2 = \frac{SC_1(R_1 + R_2) + 1}{-SC_2R_1(SC_1R_2 + 1)} = \frac{\frac{S}{2\pi f_z} + 1}{-A \cdot S \left(\frac{S}{2\pi f_p} + 1 \right)}$$

where

$$f_z = \frac{1}{2\pi C_1(R_1 + R_2)}, f_p = \frac{1}{2\pi C_1 R_2}, A = R_1 C_2.$$

One of the poles is located at origin to help achieve the highest DC gain. So there are three parameters to determine, the position of the zero, the position of the second pole, and the constant A. To determine the cutoff frequency and phase margin, the loop bode plots need to be generated. The loop transfer function is:

$$TF = -TF1 \times TF2$$

By choosing the zero close to the double pole position and the second pole to half of the switching frequency, the closed loop transfer function turns out to be very good.

That is, if $f_z = 1.32 \text{ kHz}$, $f_p = 153 \text{ kHz}$, and $A = 4.8 \times 10^{-6} \Omega F$, then the cutoff frequency will be 50 kHz, the phase margin will be 72°, and the DC gain will be that of the error amplifier. See Figure 6 below.

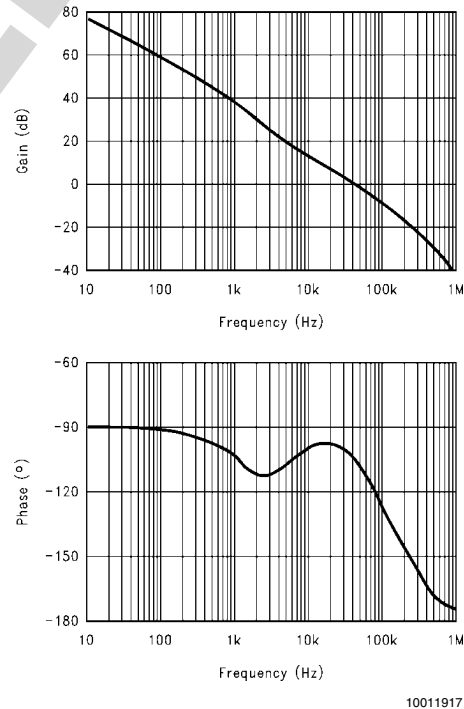

FIGURE 6. Loop Bode Plots

The compensation network component values can be determined by the following equations:

$$C_1 R_1 = \frac{1}{2\pi} \cdot \left(\frac{1}{f_z} - \frac{1}{f_p} \right), C_1 R_2 = \frac{1}{2\pi f_p}, C_2 = \frac{A}{R_1}$$

Notice there are three equations but four variables. So one of the variables can be chosen arbitrarily. Since the current driving capability of the error amplifier is limited to around 3 mA, it is a good idea to have a high impedance path from the output of the error amplifier to the output of the converter. From the above equations it can be told that a larger R_2 will result in a smaller C_1 , C_2 and a larger R_1 . However, too large an R_1 can also bring error due to the bias current required by the inverting input pin of the error amplifier. Calculations show that the following combination is a good one: $R_2 = 51\Omega$, $C_1 = 0.022\ \mu\text{F}$, $R_1 = 5.6\ \text{k}\Omega$, $C_2 = 820\ \text{pF}$.

For a different application or different type of output capacitors, a different compensation scheme may be necessary. The user can either follow the steps above to figure the appropriate component values or contact the factory for help.

MOSFET SELECTION

The selection of MOSFET switches affects both the efficiency of the whole converter and the current limit setting. From an efficiency point of view it is suggested that for the high-side switch, only logic level MOSFETs be used. Standard MOSFETs can be used for the low side switch when 12V is used to power the BOOTV pin. The lower loss associated with the MOSFETs is two-fold—Ohmic loss and switching loss. The Ohmic loss is easy to calculate whereas the switching loss is much more difficult to estimate. In general the switching loss is directly proportional to the switching frequency. As the power MOSFET technology advances, lower and lower gate charge devices will be available. That should allow the user to go to higher switching frequencies without the penalty of losing too much efficiency.

As an example, let us select the MOSFETs for a converter with a target efficiency of 80% at a load of 2.8V, 14A. Assume the inductors lose 1W, the capacitors lose 0.75W and the total switching loss at 300 kHz is 3.2W. The total allowed power loss is 9.8W, so the MOSFET Ohmic loss should not exceed 4.9W. Assume the two switches have the same conduction loss, i.e., 2.5W each, then the ON resistance for the two switches is:

$$R_{DS_ON_1} = \frac{P_{FET1}}{I_o^2 \times D} = \frac{2.5W}{(14A)^2 \times 0.62} = 20.6\ \text{m}\Omega$$

$$R_{DS_ON_2} = \frac{P_{FET2}}{I_o^2 \times (1-D)} = \frac{2.5W}{(14A)^2 \times (1-0.62)} = 33.5\ \text{m}\Omega$$

The low side switch ON resistance is much higher than the high side because at 2.8V the duty cycle is higher than 50% and becomes even larger at full load. For the high side switch, an IRL3202 (TO-220 package) or IRL3202S (D²PAK) should be sufficient. For the low side switch, an IRL3303 (TO-220 package) or IRL3303S (D²PAK) should be sufficient. Since each FET is dissipating $3.2W/2 + 2.5W = 4.1W$, it is suggested that appropriate heat sinks be used in the case of TO-220 package or large enough copper area be connected to the drain in the case of surface mount package.

CAPACITOR SELECTION

The selection of capacitors is an extremely important step when designing a converter for a load such as the Pentium II. Since the typical slew rate of the load current during a large load transient is around 20A/ μs to 30A/ μs , the switching converter has to rely on the output capacitors to take care of the first few microseconds. Under such a current slew rate, ESR of the output capacitors is more of a concern than the ESL.

Depending on the kind of capacitors being used, capacitance of the output capacitors may or may not be an important factor. When the output capacitance is too low, the converter may have to have a small output inductor to quickly supply current to the output capacitors when the load suddenly kicks in and to quickly stop supplying current when the load is suddenly removed.

Multilayer ceramic (MLC) capacitors can have very low ESR but also a low capacitance value compared to other kinds of capacitors. Low ESR aluminum electrolytic capacitors tend to have large sizes and capacitances. Tantalum electrolytic capacitors can have a fairly low ESR with a much smaller size and capacitance than the aluminum capacitors. Certain OS-CON capacitors present ultra low ESR and long life span. By the time the total ESR of the output capacitor bank reaches around 9 m Ω , the capacitance of the aluminum/tantalum/OS-CON capacitors is usually already in the millifarad range. For those capacitors, ESR is the only factor to consider. MLCs can have the same amount of total ESR with much less capacitance, most probably under 100 μF . A very small inductor, ultra fast control loop and a high switching frequency become necessary in such a case to deal with the fast charging/discharging rate of the output capacitor bank.

From a cost savings point of view, aluminum electrolytic capacitors are the most popular choice for output capacitors. They have reasonably long life span and they tend to have huge capacitance to withstand the charging or discharging process during a load transient for a fairly long period. Sanyo MV-GX series gives good performance when enough of the capacitors are paralleled. The 6MV1500GX capacitor has a typical ESR of 44 m Ω . Five of these capacitors should be sufficient in the case of on-board power supply for a Pentium II motherboard.

The challenge for input capacitors is the ripple current. The large ripple current drawn by the high side switch tends to generate quite some heat due to the capacitor ESR. The ripple current ratings in the capacitor catalogs are usually specified under the highest allowable temperature. In the case of desktop applications, those ratings seem too conservative. A good way to ensure enough number of capacitors is through lab evaluation. The input current RMS ripple value can be determined by the following equation:

$$I_{rms_rip} = I_o \cdot \sqrt{D(1-D)}$$

and the power loss in each input capacitor is:

$$P_d = \frac{I_{rms_rip}^2 \times ESR}{n^2}$$

In the case of Pentium II power supply, the maximum output current is around 14A. Under the worst case when duty cycle is 50%, the maximum input capacitor RMS ripple current is half of output current, i.e., 7A. It is found that three Sanyo 16MV820GX capacitors are enough under room temperature. The typical ESR of those capacitors is 44 m Ω . So the power loss in each of them is around $(7A)^2 \times 44\ \text{m}\Omega/3^2 = 0.24W$. Note that the power loss in each capacitor is inversely proportional to the square of the total number of capacitors, which means the power loss in each capacitor quickly drops when the number of capacitors increases.

INDUCTOR SELECTION

The size of the output is determined by a number of parameters. Basically the larger the inductor, the smaller the output ripple voltage, but the slower the converter's response speed during a load transient. On the other hand, a smaller inductor requires higher switching frequency to maintain the same level of output ripple, and probably results in a more lossy converter, but has less inertia responding to load transient. In the case of Pentium II power supply, fast recovery of the load voltage from transient window back to the steady state window is considered important. This limits the highest inductance value that can be used. The lowest inductance value is limited by the highest switching frequency that can be practically employed. As the switching frequency increases, the switching loss in the MOSFETs tends to increase, resulting in less converter efficiency and larger heat sinks. A good switching frequency is probably a frequency under which the MOSFET conduction loss is higher than the switching loss because the cost of the MOSFET is directly related to its R_{DSON} . The inductor size can be determined by the following equation:

$$L = \frac{\text{ESR} \times V_o}{V_{o_rip} \cdot f} \times \frac{V_{in} - V_o}{V_{in}}$$

where V_{O_RIP} is the peak-to-peak output ripple voltage, f is the switching frequency. For commonly used low R_{DSON} MOSFETs, a reasonable switching frequency is 300 kHz. Assume an output peak-peak ripple voltage of 18 mV is to be guaranteed, the total output capacitor ESR is 9 m Ω , the input voltage is 5V, and output voltage is 2.8V. The inductance value according to the above equation will then be 2 μH . The highest slew rate of the inductor current when the load changes from no load to full load can be determined as follows:

$$\frac{di_L}{dt} = \frac{V_{in} \cdot D_{\text{max}} - V_o}{L}$$

where D_{MAX} is the maximum allowed duty cycle, which is around 0.9 for LM2635. For a load transient from 0A to 14A, the highest current slew rate of the inductor, according to the above equation, is 0.85A/ μs , and therefore the shortest possible total recovery time is $14\text{A}/(0.85\text{A}/\mu\text{s}) = 16.5 \mu\text{s}$. Notice that the output voltage starts to recover whenever the inductor starts to supply current.

The highest slew rate of the inductor current when the load changes from full load to no load can be determined from the same equation, but use D_{MIN} instead of D_{MAX} .

Since the D_{MIN} of LM2635 at 300 kHz is 0%, the slew rate is therefore $-1.4\text{A}/\mu\text{s}$. So the approximate total recovery time will be $14\text{A}/(1.4\text{A}/\mu\text{s}) = 10 \mu\text{s}$.

The input inductor is for limiting the input current slew rate during a load transient. In the case that low ESR aluminum electrolytic capacitors are used for the input capacitor bank, voltage change due to capacitor charging/discharging is usually negligible for the first 20 μs . ESR is by far the dominant factor in determining the amount of capacitor voltage undershoot/overshoot due to load transient. So the worst case is when the load changes between no load and full load, under which condition the input inductor sees the highest voltage change across the input capacitors. Assume the input capacitor bank is made up of three 16MV820GX, i.e., the total ESR is 15 m Ω . Whenever there is a sudden load current change, it has to initially be supported by the input capacitor bank instead of the input inductor. So for a full load swing between 0A and 14A, the voltage seen by the input inductor is $\Delta V =$

$14\text{A} \times 15 \text{ m}\Omega = 210 \text{ mV}$. Use the following equation to determine the minimum inductance value:

$$L_{in} = \frac{\Delta V}{\left(\frac{di}{dt}\right)_{\text{max}}}$$

where $(di/dt)_{\text{MAX}}$ is the maximum allowable input current slew rate, which is 0.1A/ μs in the case of the Pentium II power supply. So the input inductor size, according to the above equation, should be 2.1 μH .

DYNAMIC POSITIONING OF LOAD VOLTAGE

Since the Intel VRM specifications have defined two operating windows for the MPU core voltage, one being the steady state window and the other the transient window, it is a good idea to dynamically position the steady state output voltage in the steady state window with respect to load current level so that the output voltage has more headroom for load transient response. This requires information about the load current. There are at least two simple ways to implement this idea with LM2635. One is to utilize the output inductor DC resistance, see Figure 7. The average voltage across the output inductor is actually that across its DC resistance. That average voltage is proportional to load current.

Since the switching node voltage V_A bounces between the input voltage and ground at the switching frequency, it is impossible to choose point A as the feedback point, otherwise the dynamic performance will suffer and the system may have some noise problems. Using a low pass filter network around the inductor, such as the one shown in the figure, seems to be a good idea. The feedback point is C.

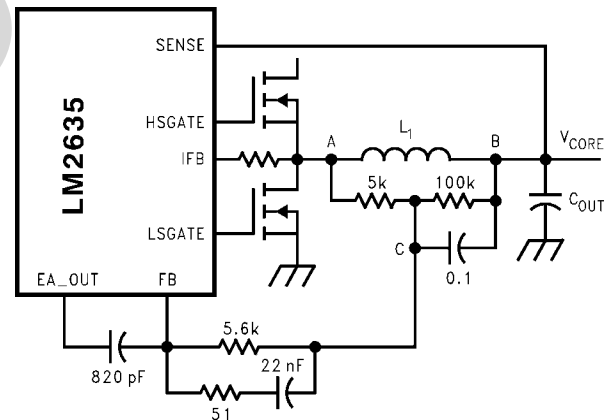

10011926

FIGURE 7. Dynamic Voltage Positioning by Utilizing Output Inductor DC Resistance

Since at the switching frequency the impedance of the 0.1 μF is much less than 5 k Ω , the bouncing voltage at point A will be mainly applied across the resistor 5 k Ω , and point C will be much quieter than A. However, V_{CB} average is still the majority of V_{AB} average, because of the resistor divider. So in steady state $V_C = I_O \times r_L + V_{\text{CORE}}$, where r_L is the inductor DC resistance. So at no load, output voltage is equal to V_C , and at full load, output voltage is $I_O \times r_L$ lower than V_C . To further utilize the steady state window, a resistor can be connected between the FB pin and ground to increase the no load output voltage to close to the upper limit of the window.

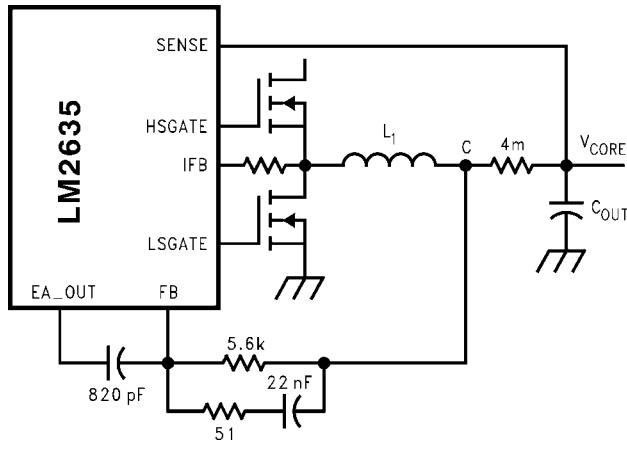

FIGURE 8. Dynamic Voltage Positioning by Using A Stand-Alone Resistor

A possible drawback of the scheme in Figure 7 is slow transient recovery speed. Since the 5 kΩ resistor and the 0.1 μF capacitor have a large time constant, the settling of point C to its steady state value during a load transient may take a few milliseconds. Depending on the interaction between the compensation network and the 0.1 μF capacitor, V_{CORE} may take different routes to reach its steady state value. This is undesired when the load transients happens more than 1000 times per second. Reducing the time constant will result in a more fluctuating V_C due to a less effective low pass filter. Fine tuning the parameters may balance the tradeoffs.

Another way to implement the dynamic voltage positioning is through the use of a stand-alone resistor, such as the 4 mΩ resistor in Figure 8 above. The advantage of this implementation over the previous one is a much faster speed of V_{CORE} from transient level to steady state level. The disadvantage is less efficiency. The total power loss can be 0.78W at 14A of load current. The cost of the resistor can be minimized by implementing it through a PCB trace.

REFERENCE VOLTAGE

The V_{REF} pin can have many uses, such as in the watchdog circuitry and in an LDO controller. Figure 9 shows an application where V_{REF} is used to build a N-FET LDO controller. An appropriate compensation network is necessary to tailor the dynamic performance of the whole power supply.

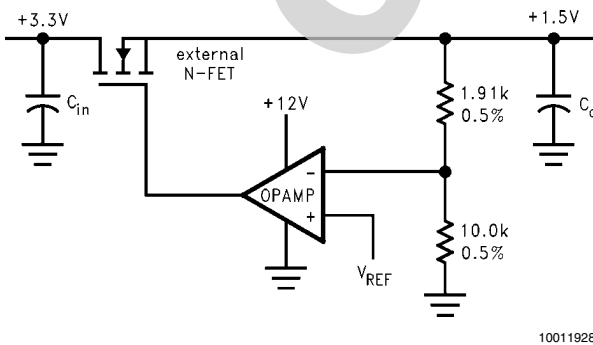

FIGURE 9. V_{REF} Used in an N-FET LDO Supply

PCB LAYOUT CONSIDERATIONS

There are several points to consider.

1. Try to use 2 oz. copper for the ground plane if tight load regulation is desired. In the case of dynamic voltage positioning, this may not be a concern because the loose load regulation is desired anyway. However, do not forget to take into consideration the voltage drop caused by the ground plane when calculating dynamic voltage positioning parameters.
2. Try to keep gate traces short. However, do not make them too short or else the LM2635 may stay too close to the MOSFETs and get heated up by them. For the same reason, do not use wide traces, 10 mil traces should be enough.
3. When not employing dynamic voltage positioning, place the feedback point at the VRM connector pins to have a tight load regulation. If it is an on-board power supply, place the feedback point at Slot I connector or wherever is closest to the MPU.
4. Start component placement with the power devices such as MOSFETs and inductors.
5. Do not place the LM2635 directly underneath the MOSFETs when surface mount MOSFETs are used.
6. If possible, keep the capacitors some distance away from the inductors so that the capacitors will have a lower temperature environment.
7. When implementing dynamic voltage positioning through a PCB trace, be aware that the PCB trace is a heat source and try to avoid placing the trace directly underneath the LM2635.

Physical Dimensions inches (millimeters) unless otherwise noted

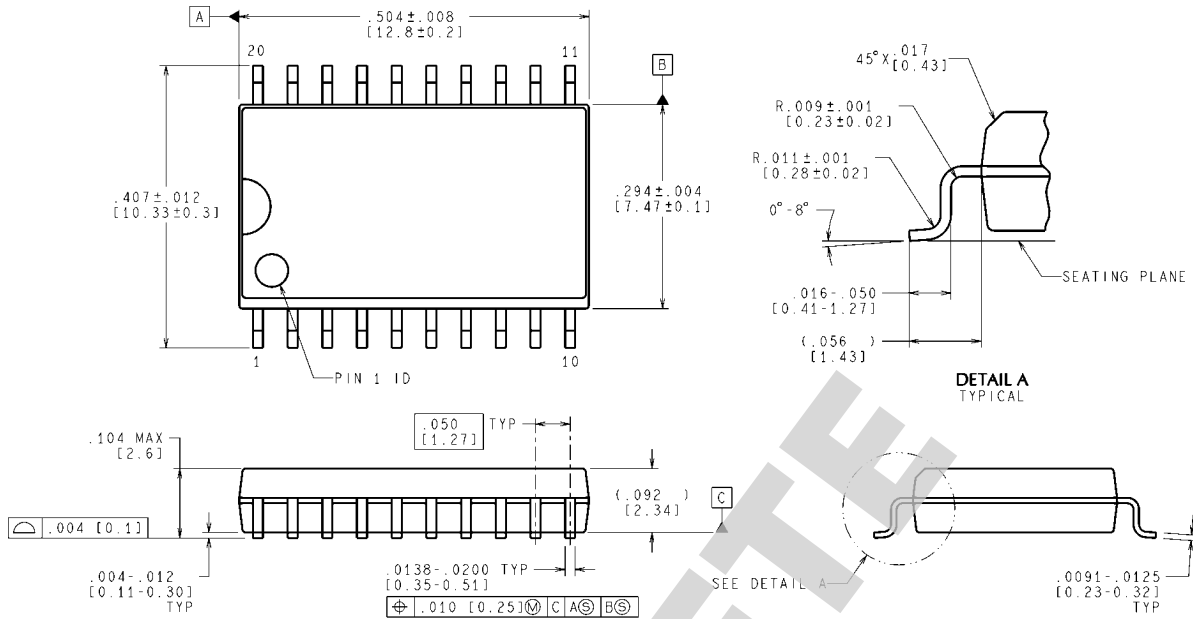

CONTROLLING DIMENSION IS INCH
VALUES IN [] ARE MILLIMETERS

20-Lead Plastic SO Package
Order Number LM2635M
NS Package Number M20B

M20B (Rev G)

OBSOLETE

Notes

For more National Semiconductor product information and proven design tools, visit the following Web sites at:
www.national.com

Products		Design Support	
Amplifiers	www.national.com/amplifiers	WEBENCH® Tools	www.national.com/webench
Audio	www.national.com/audio	App Notes	www.national.com/appnotes
Clock and Timing	www.national.com/timing	Reference Designs	www.national.com/refdesigns
Data Converters	www.national.com/adc	Samples	www.national.com/samples
Interface	www.national.com/interface	Eval Boards	www.national.com/evalboards
LVDS	www.national.com/lvds	Packaging	www.national.com/packaging
Power Management	www.national.com/power	Green Compliance	www.national.com/quality/green
Switching Regulators	www.national.com/switchers	Distributors	www.national.com/contacts
LDOs	www.national.com/ldo	Quality and Reliability	www.national.com/quality
LED Lighting	www.national.com/led	Feedback/Support	www.national.com/feedback
Voltage References	www.national.com/vref	Design Made Easy	www.national.com/easy
PowerWise® Solutions	www.national.com/powerwise	Applications & Markets	www.national.com/solutions
Serial Digital Interface (SDI)	www.national.com/sdi	Mil/Aero	www.national.com/milaero
Temperature Sensors	www.national.com/tempensors	SolarMagic™	www.national.com/solarmagic
PLL/VCO	www.national.com/wireless	PowerWise® Design University	www.national.com/training

THE CONTENTS OF THIS DOCUMENT ARE PROVIDED IN CONNECTION WITH NATIONAL SEMICONDUCTOR CORPORATION ("NATIONAL") PRODUCTS. NATIONAL MAKES NO REPRESENTATIONS OR WARRANTIES WITH RESPECT TO THE ACCURACY OR COMPLETENESS OF THE CONTENTS OF THIS PUBLICATION AND RESERVES THE RIGHT TO MAKE CHANGES TO SPECIFICATIONS AND PRODUCT DESCRIPTIONS AT ANY TIME WITHOUT NOTICE. NO LICENSE, WHETHER EXPRESS, IMPLIED, ARISING BY ESTOPPEL OR OTHERWISE, TO ANY INTELLECTUAL PROPERTY RIGHTS IS GRANTED BY THIS DOCUMENT.

TESTING AND OTHER QUALITY CONTROLS ARE USED TO THE EXTENT NATIONAL DEEMS NECESSARY TO SUPPORT NATIONAL'S PRODUCT WARRANTY. EXCEPT WHERE MANDATED BY GOVERNMENT REQUIREMENTS, TESTING OF ALL PARAMETERS OF EACH PRODUCT IS NOT NECESSARILY PERFORMED. NATIONAL ASSUMES NO LIABILITY FOR APPLICATIONS ASSISTANCE OR BUYER PRODUCT DESIGN. BUYERS ARE RESPONSIBLE FOR THEIR PRODUCTS AND APPLICATIONS USING NATIONAL COMPONENTS. PRIOR TO USING OR DISTRIBUTING ANY PRODUCTS THAT INCLUDE NATIONAL COMPONENTS, BUYERS SHOULD PROVIDE ADEQUATE DESIGN, TESTING AND OPERATING SAFEGUARDS.

EXCEPT AS PROVIDED IN NATIONAL'S TERMS AND CONDITIONS OF SALE FOR SUCH PRODUCTS, NATIONAL ASSUMES NO LIABILITY WHATSOEVER, AND NATIONAL DISCLAIMS ANY EXPRESS OR IMPLIED WARRANTY RELATING TO THE SALE AND/OR USE OF NATIONAL PRODUCTS INCLUDING LIABILITY OR WARRANTIES RELATING TO FITNESS FOR A PARTICULAR PURPOSE, MERCHANTABILITY, OR INFRINGEMENT OF ANY PATENT, COPYRIGHT OR OTHER INTELLECTUAL PROPERTY RIGHT.

LIFE SUPPORT POLICY

NATIONAL'S PRODUCTS ARE NOT AUTHORIZED FOR USE AS CRITICAL COMPONENTS IN LIFE SUPPORT DEVICES OR SYSTEMS WITHOUT THE EXPRESS PRIOR WRITTEN APPROVAL OF THE CHIEF EXECUTIVE OFFICER AND GENERAL COUNSEL OF NATIONAL SEMICONDUCTOR CORPORATION. As used herein:

Life support devices or systems are devices which (a) are intended for surgical implant into the body, or (b) support or sustain life and whose failure to perform when properly used in accordance with instructions for use provided in the labeling can be reasonably expected to result in a significant injury to the user. A critical component is any component in a life support device or system whose failure to perform can be reasonably expected to cause the failure of the life support device or system or to affect its safety or effectiveness.

National Semiconductor and the National Semiconductor logo are registered trademarks of National Semiconductor Corporation. All other brand or product names may be trademarks or registered trademarks of their respective holders.

Copyright© 2011 National Semiconductor Corporation

For the most current product information visit us at www.national.com



www.national.com

**National Semiconductor
Americas Technical
Support Center**

Email: support@nsc.com
Tel: 1-800-272-9959

**National Semiconductor Europe
Technical Support Center**

Email: europe.support@nsc.com

**National Semiconductor Asia
Pacific Technical Support Center**

Email: ap.support@nsc.com

**National Semiconductor Japan
Technical Support Center**

Email: jpn.feedback@nsc.com