

Description

The ICS3726-02 is a low cost, low-jitter, high-performance VCXO designed to replace expensive discrete VCXOs modules. The ICS3726-02 offers a wide operating frequency range and high power supply noise rejection. Using ICS' patented VCXO techniques, the device accepts an inexpensive external pullable crystal in the range of 24 to 36 MHz to produce a VCXO output clock at the same frequency.

The frequency of the on-chip VCXO is adjusted by an external control voltage input into pin VIN. Because VIN is a high-impedance input, it can be driven directly from an PWM RC integrator circuit. Frequency output increases with VIN voltage input. The usable range of VIN is 0 to 3.3 V.

This part is ideal for Set-Top Box, multimedia clock synthesizers and ADSL/VDSL applications.

Features

- Packaged in 8-pin SOIC
- Operational frequency range of 24 MHz to 36 MHz
- Uses an inexpensive external pullable crystal
- On-chip patented VCXO with pull range of ± 115 ppm
- VCXO tuning voltage of 0 to 3.3 V
- Output Enable control
- 12 mA output drive capability at TTL levels
- Advanced, low-power, sub-micron CMOS process
- Available in Pb (lead) free package

Block Diagram

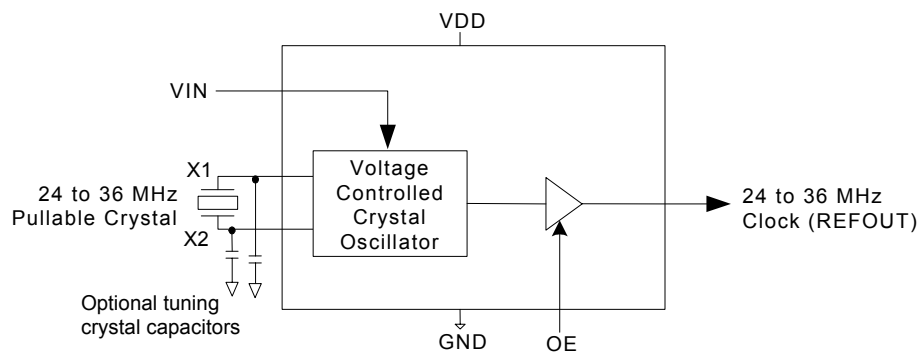

Pin Assignment

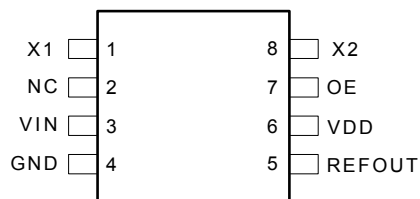

ICS3726-02

8-Pin (150 mil) SOIC

Pin Descriptions

Pin Number	Pin Name	Pin Type	Pin Description
1	X1	Input	Crystal connection. Connect to an external pullable crystal.
2	NC	—	Do not connect this pin to anything.
3	VIN	Input	Control input to VCXO. 0 to 3.3 V signal which varies the VCXO output frequency.
4	GND	Power	Connect to ground.
5	REFOUT	Output	VCXO clock output.
6	VDD	Power	Connect to +3.3 V.
7	OE	Input	Output enable, OE=1 enables output, OE=0 disable output, internal pull-up.
8	X2	Input	Crystal connection. Connect to a pullable 24 to 36 MHz crystal.

External Component Selection

The ICS3726-02 requires a minimum number of external components for proper operation.

Decoupling Capacitors

A decoupling capacitor of 0.01 μ F should be connected between VDD and GND on pins 6 and 4 as close to the ICS3726-02 as possible. For optimum device performance, the decoupling capacitor should be mounted on the component side of the PCB. Avoid the use of vias in the decoupling circuit.

Series Termination Resistor

When the PCB trace between the clock output and the load is over 1 inch, series termination should be used. To series terminate a 50 Ω trace (a commonly used trace impedance), place a 33 Ω resistor in series with the clock line, as close to the clock output pin as possible. The nominal impedance of the clock output is 20 Ω .

Quartz Crystal

The ICS3726-02 VCXO function consists of the external crystal and the integrated VCXO oscillator circuit. To assure the best system performance (frequency pull range) and reliability, a crystal device with the recommended parameters (shown below) must be used, and the layout guidelines discussed in the following section shown must be followed.

The oscillation frequency of a quartz crystal is determined by its “cut” and by the load capacitors connected to it. The ICS3726-02 incorporates on-chip variable load capacitors that pull (change) the frequency of the crystal. The crystal specified for use with the ICS3726-02 is designed to have zero frequency error when the total of on-chip + stray capacitance is 10 pF.

Recommended Crystal Parameters:

Initial Accuracy at 25°C	\pm 20 ppm
Temperature Stability	\pm 30 ppm
Aging	\pm 20 ppm
Load Capacitance	14 pF
Shunt Capacitance, C0	7 pF max
C0/C1 Ratio	250 max
Equivalent Series Resistance	35 Ω max

The external crystal must be connected as close to the chip as possible and should be on the same side of the PCB as the ICS3726-02. There should be no via's between the crystal pins and the X1 and X2 device pins. There should be no signal traces underneath or close to the crystal. See application note MAN05.

Crystal Tuning Load Capacitors

The crystal traces should include pads for small fixed capacitors, one between X1 and ground, and another between X2 and ground. Stuffing of these capacitors on the PCB is optional. The need for these capacitors is determined at system prototype evaluation, and is influenced by the particular crystal used (manufacture and frequency) and by PCB layout. The typical required capacitor value is 1 to 4 pF. This chip has internal load capacitors and is designed to work with surface mount crystals with 10 pF load capacitance.

The procedure for determining the value of these capacitors can be found in application note MAN05.

Absolute Maximum Ratings

Stresses above the ratings listed below can cause permanent damage to the ICS3726-02. These ratings, which are standard values for ICS commercially rated parts, are stress ratings only. Functional operation of the device at these or any other conditions above those indicated in the operational sections of the specifications is not implied. Exposure to absolute maximum rating conditions for extended periods can affect product reliability. Electrical parameters are guaranteed only over the recommended operating temperature range.

Item	Rating
Supply Voltage, VDD	7 V
All Inputs and Outputs	-0.5 V to VDD+0.5 V
Ambient Operating Temperature	0 to +70°C
Storage Temperature	-65 to +150°C
Soldering Temperature	260°C

Recommended Operation Conditions

Parameter	Min.	Typ.	Max.	Units
Ambient Operating Temperature	0	–	+70	°C
Power Supply Voltage (measured in respect to GND)	+3.135		+3.465	V
Reference crystal parameters	Refer to page 3			

DC Electrical Characteristics

VDD=3.3 V ±5% , Ambient temperature 0 to +70°C, unless stated otherwise

Parameter	Symbol	Conditions	Min.	Typ.	Max.	Units
Operating Voltage	VDD		3.135		3.465	V
Output High Voltage	V _{OH}	I _{OH} = -12 mA	2.4			V
Output Low Voltage	V _{OL}	I _{OL} = 12 mA			0.4	V
Output High Voltage (CMOS Level)	V _{OH}	I _{OH} = -4 mA	VDD-0.4			V
Operating Supply Current	IDD	No load		6		mA
Short Circuit Current	I _{OS}			±50		mA
VIN, VCXO Control Voltage	V _{IA}		0		3.3	V

AC Electrical Characteristics

VDD = 3.3 V ±5%, Ambient Temperature 0 to +70° C, unless stated otherwise

Parameter	Symbol	Conditions	Min.	Typ.	Max.	Units
Output Frequency	F _O		24		36	MHz
Crystal Pullability	F _P	0V ≤ VIN ≤ 3.3 V, Note 1	± 115			ppm
VCXO Gain		VIN = VDD/2 ± 1 V, Note 1		150		ppm/V
Output Rise Time	t _{OR}	0.8 to 2.0 V, C _L =15 pF		0.5	1.5	ns
Output Fall Time	t _{OF}	2.0 to 0.8 V, C _L =15 pF		0.6	1.5	ns
Output Clock Duty Cycle	t _D	Measured at 1.4 V, C _L =15 pF	40	50	60	%
Period Jitter RMS	t _J	C _L =15 pF @ 35.328 MHz		8		ps
Period Jitter P- P	t _J	C _L =15 pF @ 35.328 MHz		90		ps
Integrated Jitter RMS		Integrated 12 kHz to 20 MHz @ 35.328 MHz		1		ps
Phase Noise relative to Carrier		@ 35.328 MHz Carrier frequency				
		@ 10 Hz		-60		dBc/Hz
		@ 100 Hz		-88		dBc/Hz
		@ 1 kHz		-117		dBc/Hz
		@ 10 kHz		-135		dBc/Hz
		@ 100 kHz		-150		dBc/Hz
		@ 1 MHz		-145		dBc/Hz

Note 1: External crystal device must conform with Pullable Crystal Specifications listed on page 3.

Package Outline and Package Dimensions (8-pin SOIC)

Package dimensions are kept current with JEDEC Publication No. 95

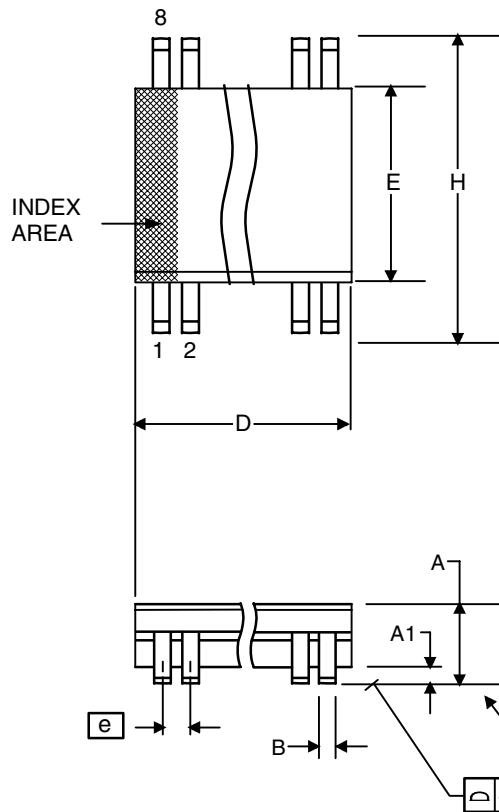

Symbol	Millimeters		Inches*	
	Min	Max	Min	Max
A	1.35	1.75	.0532	.0688
A1	0.10	0.25	.0040	.0098
B	0.33	0.51	.013	.020
C	0.19	0.25	.0075	.0098
D	4.80	5.00	.1890	.1968
E	3.80	4.00	.1497	.1574
e	1.27 BASIC		0.050 BASIC	
H	5.80	6.20	.2284	.2440
h	0.25	0.50	.010	.020
L	0.40	1.27	.016	.050
α	0°	8°	0°	8°

*For reference only. Controlling dimensions in mm.

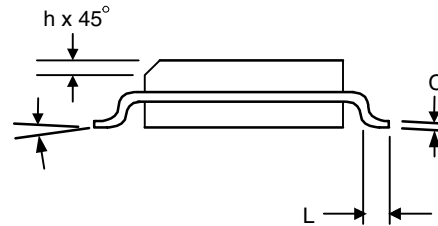

Ordering Information

Part / Order Number	Marking	Shipping Packaging	Package	Temperature
ICS3726M-02	3726M-02	Tubes	8-pin SOIC	0 to +70° C
ICS3726M-02T	3726M-02	Tape and Reel	8-pin SOIC	0 to +70° C
ICS3726M-02LF	3726M02L	Tubes	8-pin SOIC	0 to +70° C
ICS3726M-02LFT	3726M02L	Tape and Reel	8-pin SOIC	0 to +70° C

Parts that are ordered with a "LF" suffix to the part number are the Pb-Free configuration and are RoHS compliant.

While the information presented herein has been checked for both accuracy and reliability, Integrated Circuit Systems (ICS) assumes no responsibility for either its use or for the infringement of any patents or other rights of third parties, which would result from its use. No other circuits, patents, or licenses are implied. This product is intended for use in normal commercial applications. Any other applications such as those requiring extended temperature range, high reliability, or other extraordinary environmental requirements are not recommended without additional processing by ICS. ICS reserves the right to change any circuitry or specifications without notice. ICS does not authorize or warrant any ICS product for use in life support devices or critical medical instruments.

Revision History

Rev.	Originator	Date	Description of Change
C	P.G.	03/07/06	Changed operational frequency range from 20/52 MHz to 24/36 MHz; updates to Pin Descriptions; numerous updates to typical values in AC chars.

IMPORTANT NOTICE AND DISCLAIMER

RENESAS ELECTRONICS CORPORATION AND ITS SUBSIDIARIES (“RENESAS”) PROVIDES TECHNICAL SPECIFICATIONS AND RELIABILITY DATA (INCLUDING DATASHEETS), DESIGN RESOURCES (INCLUDING REFERENCE DESIGNS), APPLICATION OR OTHER DESIGN ADVICE, WEB TOOLS, SAFETY INFORMATION, AND OTHER RESOURCES “AS IS” AND WITH ALL FAULTS, AND DISCLAIMS ALL WARRANTIES, EXPRESS OR IMPLIED, INCLUDING, WITHOUT LIMITATION, ANY IMPLIED WARRANTIES OF MERCHANTABILITY, FITNESS FOR A PARTICULAR PURPOSE, OR NON-INFRINGEMENT OF THIRD PARTY INTELLECTUAL PROPERTY RIGHTS.

These resources are intended for developers skilled in the art designing with Renesas products. You are solely responsible for (1) selecting the appropriate products for your application, (2) designing, validating, and testing your application, and (3) ensuring your application meets applicable standards, and any other safety, security, or other requirements. These resources are subject to change without notice. Renesas grants you permission to use these resources only for development of an application that uses Renesas products. Other reproduction or use of these resources is strictly prohibited. No license is granted to any other Renesas intellectual property or to any third party intellectual property. Renesas disclaims responsibility for, and you will fully indemnify Renesas and its representatives against, any claims, damages, costs, losses, or liabilities arising out of your use of these resources. Renesas' products are provided only subject to Renesas' Terms and Conditions of Sale or other applicable terms agreed to in writing. No use of any Renesas resources expands or otherwise alters any applicable warranties or warranty disclaimers for these products.

(Disclaimer Rev.1.0 Mar 2020)

Corporate Headquarters

TOYOSU FORESIA, 3-2-24 Toyosu,
Koto-ku, Tokyo 135-0061, Japan
www.renesas.com

Contact Information

For further information on a product, technology, the most up-to-date version of a document, or your nearest sales office, please visit:
www.renesas.com/contact/

Trademarks

Renesas and the Renesas logo are trademarks of Renesas Electronics Corporation. All trademarks and registered trademarks are the property of their respective owners.