



DEMOAX9S12

Demonstration Board for Freescale Microcontrollers

Supporting
MC9S12P128
MC9S12XEP100
MC9S12XS128

HARDWARE USER GUIDE



Web Site: www.axman.com

Support: support@axman.com

CONTENTS

CAUTIONARY NOTES	4
TERMINOLOGY.....	4
FEATURES	5
BOARD FEATURES	6
REFERENCE MANUAL.....	6
DEVELOPMENT SUPPORT	6
OSBDM BOOTLOADER.....	7
BKGD HEADER, J20.....	7
POWER.....	7
POWER SELECT	8
RESET SWITCH	8
LOW VOLTAGE RESET	8
TIMING.....	8
COMMUNICATIONS.....	8
COM_EN.....	9
LIN PORT.....	9
LIN CONNECTOR.....	10
CAN PORT	10
USER PERIPHERALS	11
USER LED'S	11
USER DIP SWITCHES.....	11
PUSHBUTTON SWITCHES.....	12
LIGHT SENSOR.....	12
IO RING.....	12
DEFAULT SHUNT POSITION	14

FIGURES

Figure 1: BKGD Header, J207
 Figure 2: PWR_SEL Option Header8
 Figure 3: COM_EN Option Header (default).....9
 Figure 4: COM_EN Option Header (default).....9
 Figure 5: LIN Block Diagram.....10
 Figure 6: LIN Connector10
 Figure 7: CAN_PORT10
 Figure 8: LED Option Header – J911
 Figure 9: DIP SWITCH Option Header – J1012
 Figure 10: IO Ring13
 Figure 11: Default Shunt Configuration14

REVISION

Date	Rev	Comments
November 18, 2013	A	Initial Release

CAUTIONARY NOTES

Electrostatic Discharge (ESD) prevention measures should be used when handling this product. ESD damage is not a warranty repair item.

Axiom Manufacturing does not assume any liability arising out of the application or use of any product or circuit described herein; neither does it convey any license under patent rights or the rights of others.

EMC Information on the DEMOAX9S12 board:

1. This product as shipped from the factory with associated cables has been verified to meet with requirements of CE and the FCC as a CLASS A product.
2. This product is designed and intended for use as a development platform for hardware or software in an educational or professional laboratory.
3. In a domestic environment, this product may cause radio interference in which case the user may be required to take adequate prevention measures.
4. Attaching additional wiring to this product or modifying the products operation from the factory default as shipped may affect its performance and cause interference with nearby electronic equipment. If such interference is detected, suitable mitigating measures should be taken.

TERMINOLOGY

This development module utilizes option select jumpers to configure default board operation. Terminology for application of the option jumpers is as follows:

Jumper – a plastic shunt that connects 2 terminals electrically

Jumper on, in, or installed = jumper is a plastic shunt that fits across 2 pins and the shunt is installed so that the 2 pins are connected with the shunt.

Jumper off, out, or idle = jumper or shunt is installed so that only 1 pin holds the shunt, no 2 pins are connected, or jumper is removed. It is recommended that the jumpers be placed idle by installing on 1 pin so they will not be lost.

Cut-Trace – a circuit trace connection between component pads. The circuit trace may be cut using a knife to break the default connection. To reconnect the circuit, simply install a suitably sized 0-ohm resistor or attach a wire across the pads.

Signal names followed by an asterisk (*) denote active-low signals.

FEATURES

The DEMOAX9S12 board is a demonstration board designed to support 3 different Freescale microprocessors: the MC9S12P128, the MC9S12XEP100, and the MC9S12XS128. These MCUs target generic automotive applications requiring CAN or LIN/J2602; such as body controllers, occupant detection, door modules, or seat controllers. Features for each MCU include; error correction code (ECC), flash memory, a separate data-flash module for data storage, an analog-to-digital converter (ATD), and a frequency modulated phase-locked-loop (FMPLL). The MC9S12XEP100 and MC9S12XS128 further apply the X-Gate co-processor, which is optimized for data movement and logic manipulation.

An integrated Open-Source BDM, software tools, and examples provided with the development board make application development and debug quick and easy. An IO Ring provides access to all available MCU signals.

Supported MCUs include:

- MC9S12P128, 80QFP
 - 128K Bytes Flash (ECC)
 - 4K Bytes Data Flash
 - 6K Bytes RAM
 - 32MHz Bus Frequency
 - Internal Oscillator
 - 8ch x 16bit Timer
 - 6ch x 8bit PWM
 - 10ch x 12bit ADC
 - SCI, SPI, CAN
- MC9S12XEP100, 112 QFP
 - 1M Byte FLASH (ECC)
 - 32K Byte Data Flash
 - 64K Byte RAM
 - 4K Byte EEPROM
 - 8ch x 16bit Timer
 - 16ch x 12bit ADC
 - 8ch x 8bit or 4ch x 16bit PWM
 - SCI, SPI, CAN, IIC
 - External Bus Interface,
- MC9S12XS128, 112 QFP
 - 256K Byte FLASH (ECC)
 - 8K Byte Data Flash
 - 12K Byte RAM
 - 8ch x 16bit Timer
 - 16ch x 12bit ADC
 - 8ch x 8bit or 4ch x 16bit PWM
 - SCI, SPI, CAN, IIC

Labeling blocks located below the MCU allow marking to indicate the MCU installed.

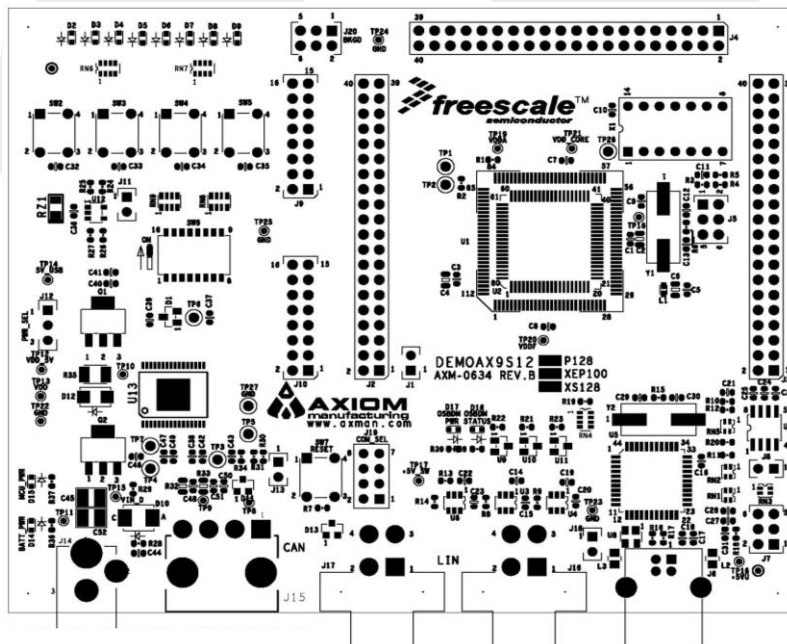

BOARD FEATURES

- Integrated Open Source BDM (OSBDM)
- BDM_PORT header for external BDM cable support
- MC33905S System Basis Chip (SBC) provides power and supports CAN and LIN communications.
- Serial Com supported through OSBDM
- RESET Push Button
- User Peripherals
 - 4 User Push Button Switches, active low
 - 8 User LED Indicators, active low, with option jumpers
 - 8-pos DIP switch, active low, with option jumpers
 - Light Sensor, photo-transistor, w/ amplifier and option jumper
- COM select Option Header to configure LIN and CAN communications
- Connectors
 - BDM Header to allow use of external BDM
 - 2.0 mm center-positive barrel connector supports power input
 - USB type-B connector for OSBDM
 - 1x4, 4.2mm, Molex CAN Cable Connector
 - 2x2, 4.2mm, Molex LIN Cable Connector

Specifications:

Board Size 5.0" x 4.0" overall

Power Input: +12VDC at barrel connector

NOTE:

CAN and LIN communications are not supported when powered from the OSBDM.

REFERENCE MANUAL

Refer to the installed MCU Reference Manual (RM) for details on use and configuration of the MCU and MCU peripherals. RMs may be found at www.freescale.com. The links below may also be used to access each RM directly.

[MC9S12P128](#) Reference Manual

[MC9S12XEP100](#) Reference Manual

[MC9S12XS128](#) Reference Manual

DEVELOPMENT SUPPORT

The DEMOAX9S12 board applies an integrated Open-Source Background Debug Mode, OSBDM, fully supporting program development and debug. CodeWarrior fully supports the OSBDM providing direct, non-intrusive access to target device internals. While in BDM mode, no internal resources are used. Code stepping and break-points are fully supported.

A USB, type-B, connector provides connection to the host PC. The target board may be powered from the OSBDM; however, using OSBDM input power allows use of the target MCU and user peripherals only. CAN and LIN communications are not supported if the target board is powered from the OSBDM. If using the OSBDM to power the target board, the user must ensure the design – and all connected wiring – does not exceed maximum current drain from the host PC. The USB Specification limits maximum current drain to 500 mA; excessive current drain may damage the target board, the host PC, or both.

CAUTION:

When powered from the USB bus, do not exceed the 500mA maximum current drain allowed under the USB specification. Damage to the target board or host PC may result

OSBDM Bootloader

The OSBDM is pre-programmed with a bootloader application to allow field updates. The USB bootloader communicates with a GUI application running on a host PC. This GUI application allows the user to update OSBDM firmware easily and quickly. Option jumper JP401 enables the bootloader at startup. This option header is not populated in default configuration. Refer to Freescale Application Note [AN3561](#) for details on using the GUI application and bootloader. This application note may also be accessed at www.freescale.com or at www.axman.com/support.

BKGD Header, J20

A compatible HCS12 BDM cable may also be used to program/ debug the target MCU. The external BDM connects to the 6-pin BDM interface header at J20. Refer to the external programming/debug cable documentation for details on use. The figure below shows the pin-out for the BKGD header.

Figure 1: BKGD Header, J20

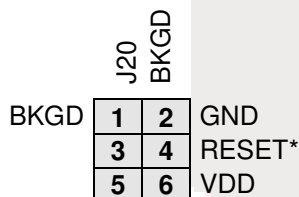

See the associated MCU RM for details on configuration, use, and capabilities of the DEBUG/BKGD port.

POWER

The DEMOAX9S12 board may be powered from the OSBDM for application development and debugging, which do not require CAN or LIN communications. The DEMOAX9S12 board may also be powered using the MC33905S, System Basis Chip for applications requiring CAN and LIN functionality. The PWR_SEL option header allows selection between power input options.

As noted above, when using the OSBDM to power the target board, the user must ensure total current drain does not exceed the maximum allowable under the USB specification.

The barrel connector at J14 allows use of the SBD to power the target design. This power input also supports use CAN and LIN communications. Input voltage must exceed +12VDC to support CAN and LIN functionality. Input voltage should not exceed +27VDC.

Power Select

The PWR_SEL option header selects the input power source for the target board. When powered from the Tower System, the OSBDM voltage output is disabled.

Figure 2: PWR_SEL Option Header

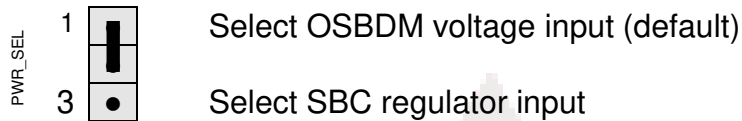

RESET SWITCH

The RESET switch applies an asynchronous RESET input to the MCU allowing the user to reset the target MCU at any time. The RESET switch is connected directly to the RESET* input on the MCU. Pressing the RESET switch applies a low voltage level to the RESET* input. A pull-up bias resistor allows normal MCU operation.

LOW VOLTAGE RESET

Each target MCU, supported by the DEMOAX9S12, applies an internal Power-On Reset (POR) circuit and an internal Low Voltage Reset (LVR) circuit to ensure proper device operation. The POR circuit holds the MCU in reset until applied voltage reaches an appropriate level. The LVR forces the device into reset if input voltage falls too low, protecting against brown-out conditions. A user configurable Low-Voltage Detect (LVD) with interrupt output is also available. Consult the installed MCU RM for details of POR, LVR, and LVD operation.

TIMING

The DEMOAX9S12 applies a 4MHz crystal (XTAL). The MC9S12P28 applies an internal enabled out of reset. Use of the external XTAL must be enabled by the user application. The MC9S12XEP100 and MC9S12XS128 enable and use the external XTAL by default. Refer to the installed MCU RM for details on using and configuring the external clock.

COMMUNICATIONS

The DEMOAX9S12 supports CAN, LIN, and serial communications. CAN and LIN communications are provided by the SBC while serial communications are supported using the OSBDM Virtual Serial Port. Refer to www.freescale.com for details on use of the OSBDM Virtual Serial Port. Refer to the [OBDM USER GUIDE Installation and Operation of the OSBDM](#) from P&E Microsystems for details on installation and use of the OSBDM Virtual Serial Port.

The MC9S12P128 applies only 1 SCI port while both the MC9S12XEP100 and the MC9S12XS128 apply multiple SCI ports. The COM_SEL option header allows the user to configure how the installed MCU communicates.

COM_EN

The COM_EN option header allows the user to configure how the installed MCU connects to either the SBC LIN port or the OSBDM Virtual Serial Port. The MC9S12P128 applies 1 SCI port while both the MC9S12XEP100 and the MC9S12XS128 apply multiple SCI ports. Figure 3 below shows default configuration for the COM_SEL option header

The COM_EN option header connects the MCU SCI port to either the SBC LIN port or the OSBDM Virtual Serial Port. Figure 3 below shows the option jumper configuration for the COM_EN option header.

Figure 3: COM_EN Option Header (default)

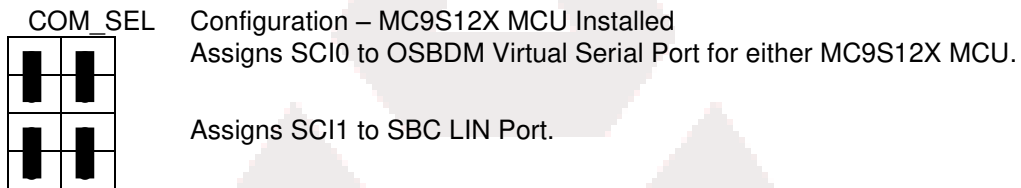
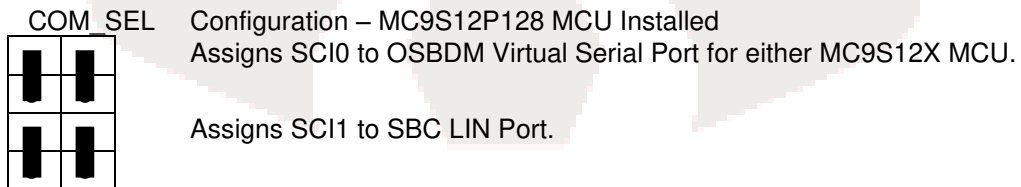

Figure 4 shows the default configuration for the COM_SEL option header with the MC9S12P128 MCU installed.

Figure 4: COM_EN Option Header (default)



LIN Port

The MC33905S System Basis Chip (SBC) supports LIN communications for the DEMOAX9S12 board. Refer to the MC33905S data sheet for details on use and configuration of LIN communications port. Figure 5 below shows the LIN block diagram.

[MC33905S](#) – System Basis Chip Gen2 w/ High-Speed CAN and LIN Interface

Figure 5: LIN Block Diagram

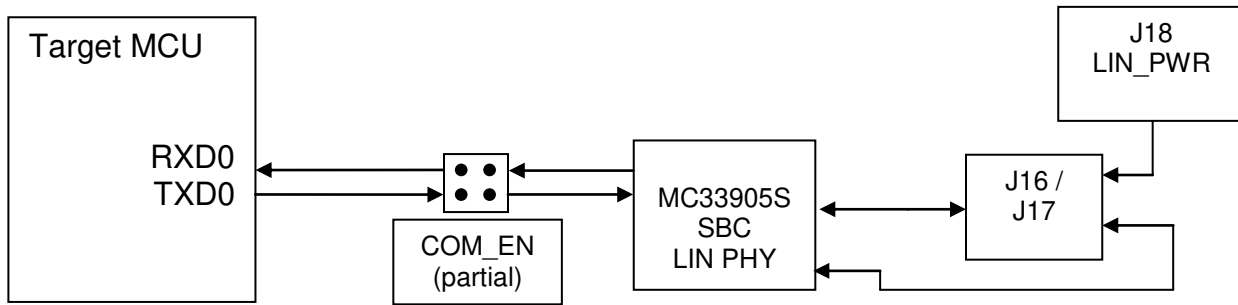

LIN Connector

The DEMOAX9S12 supports two, 2 x 2 Molex connectors to interface to the LIN bus. Figure 6 below shows the pin-out of the LIN bus connector. Only 1 connector is installed in default configurations.

Figure 6: LIN Connector

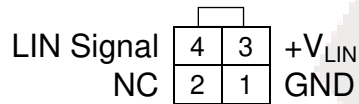

Front View – Looking into Connector

NOTE: LIN Port Connector – Molex 39-29-1048
Mates with; Housing – Molex 39-01-2040, Pin – Molex 39-00-0036

CAN Port

The MC33905S System Basis Chip (SBC) supports CAN communications for the DEMOAX9S12 board. Refer to the MC33905S data sheet for details on use and configuration of CAN communications port. Figure 7 below shows the CAN connector pin-out.

[MC33905S](#) – System Basis Chip Gen2 w/ High-Speed CAN and LIN Interface

Figure 7: CAN_PORT

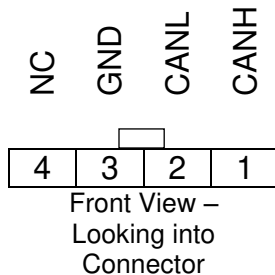

NOTE: CAN Port Connector – Molex 39-30-3045
Mates with; Housing – Molex 39-01-4040, Pin – Molex 39-00-0217









USER PERIPHERALS

User I/O for the DEMOAX9S12 includes 1 light sensor, 4 push button switches, and 8 DIP switches, and 8 green LEDs. Option headers at J9, J10, and J11 allow the user to enable or disable all User I/O except the push-buttons. Push-buttons are open by default and do not require option jumpers. Refer to the figures below for configuration of each USER jumper settings.

User LED's

The DEMOAX9S12 applies 8, green LEDs for output indication. Each LED is configured for active-low operation. A series, current-limit resistor prevents excessive diode current. Figure 8 below shows the USER jumper settings.

Figure 8: LED Option Header – J9

	J9	Signal
D2		PA7
D3		PA6
D4		PA5
D5		PA4
D6		PA3
D7		PA2
D8		PA1
D9		PA0

User DIP Switches

The DEMOAX9S12 applies 8, DIP Switches for user input. Each DIP switch is configured for active-low operation. A series, current-limit resistor prevents excessive diode current. Figure 8 below shows the USER jumper settings.

Figure 9: DIP SWITCH Option Header – J10

	J10	Signal
SW1		PA7
SW2		PA6
SW3		PA5
SW4		PA4
SW5		PA3
SW6		PA2
SW7		PA1
SW8		PA0

Pushbutton Switches

The DEMOAX9S12 applies 4 push-button switches for user input. Each push-button switch is configured for active-low operation and is connected to a key-wakeup input on the target MCU. No bias is applied to these push-button inputs; use of target MCU internal pull-ups is required for proper operation. No option header is applied to user push-button inputs.

Light Sensor

The DEMOAX9S12 applies 1 photosensitive transistor Light Sensor. The light sensor exhibits maximum sensitivity in the visible light spectrum (600nm). A gain stage amplifies the sensor output for use by the target MCU. Connection to MCU input signal PAD08 allows analog processing. An option header at J11 allows the user to enable or disable the amplifier output.

IO RING

The DEMOAX9S12 applies an IO Ring allowing access to all MCU signals. Figure 10 below shows connections for each of the 3 elements of the IO Ring.

Figure 10: IO Ring

The illustrations below show signal connections to the IO Ring headers, IO Ring headers are not installed in default configurations.

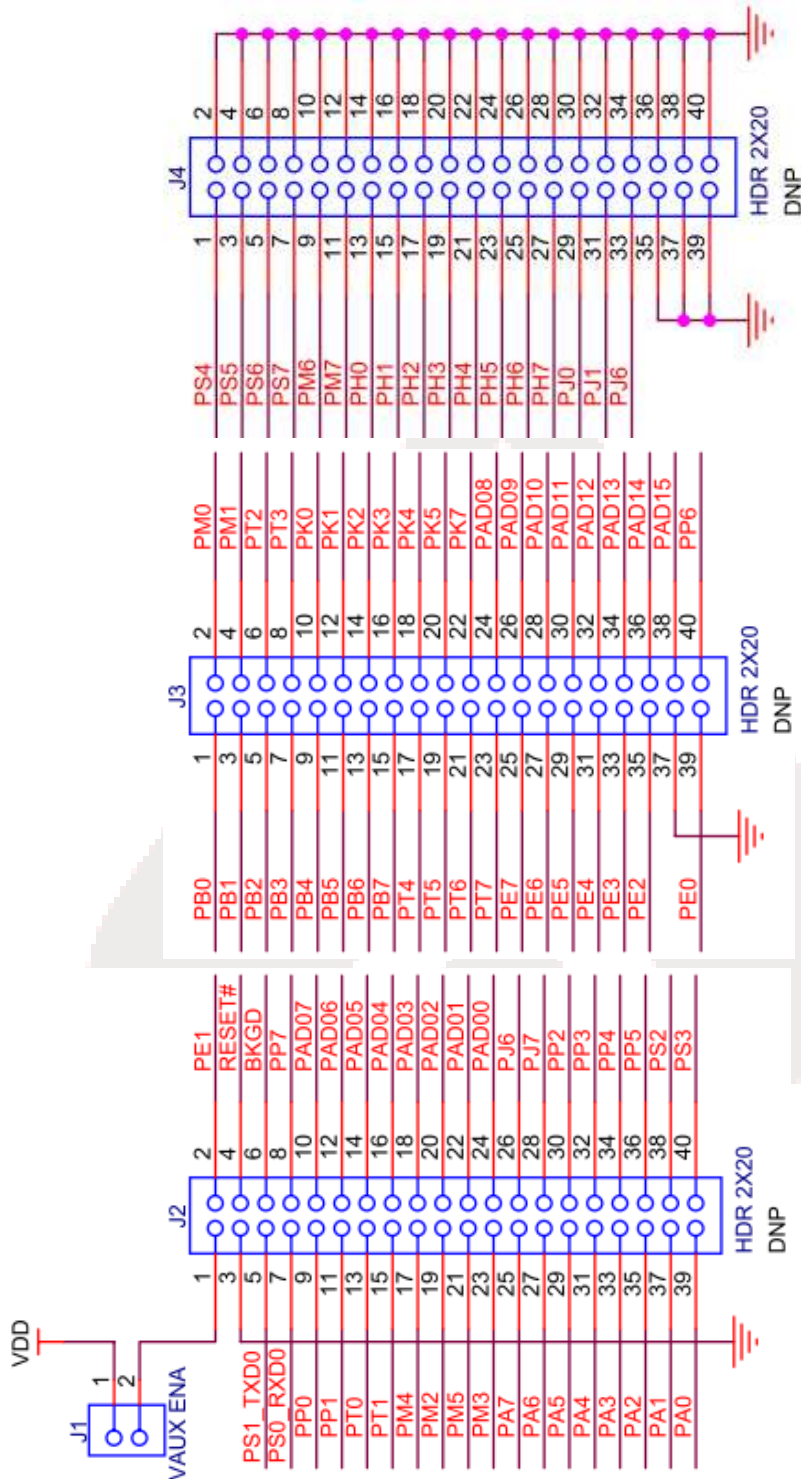

DEFAULT SHUNT POSITION

Figure 11: Default Shunt Configuration

