

REV.	DATE	ECR NO.	DESCRIPTION
NC	09/23/10	XXXXXX	INITIAL RELEASE

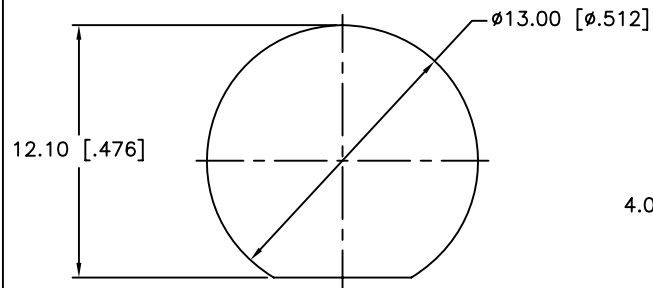

RECOMMENDED MOUNTING HOLE

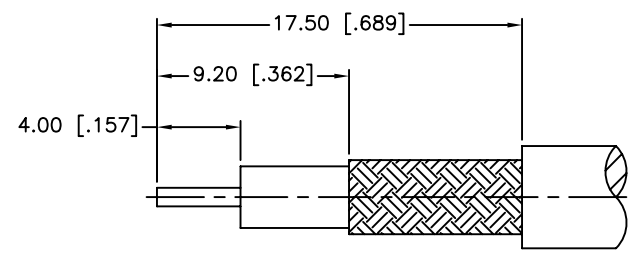

RECOMMENDED CABLE STRIPPING DIM'S

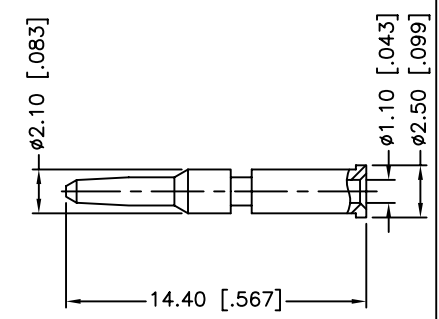
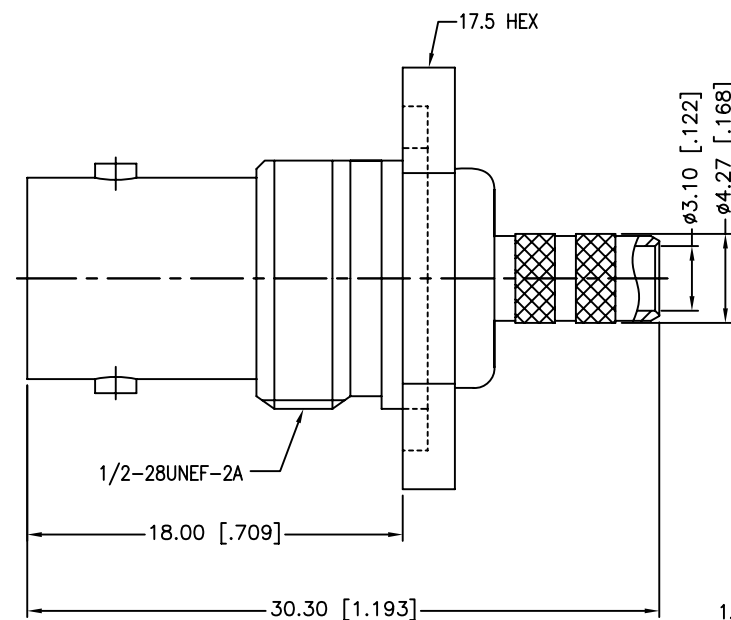
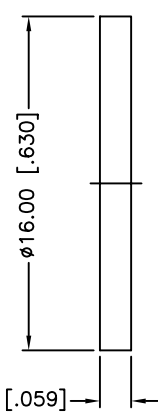
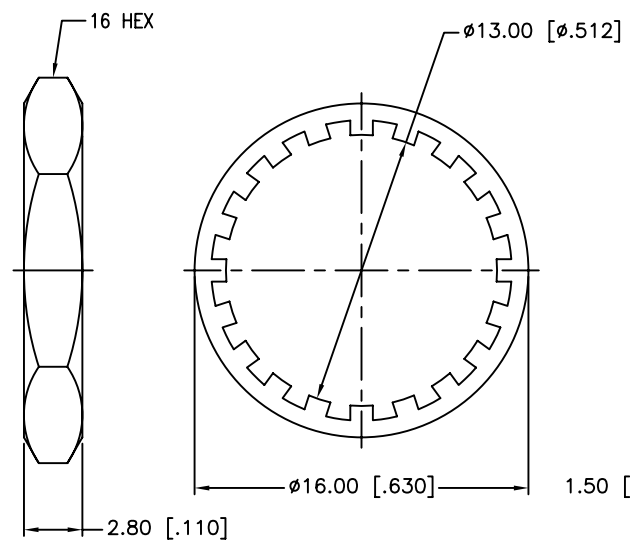
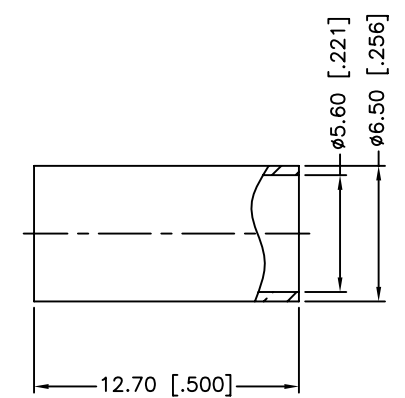

1. CRIMPED FERRULE HEX CRIMP SIZE .213"
2. CRIMPED CONTACT PIN HEX CRIMP SIZE .068"
3. MAX. PANEL THICKNESS=3.5mm

DESCRIPTION	MATERIAL	FINISH	QTY
9 FERRULE	BRASS	NICKEL	1
8 CONTACT PIN	BRASS	GOLD	1
7 HEX NUT	BRASS	NICKEL	1
6 LOCK WASHER	BRASS	NICKEL	1
5 GASKET	RUBBER	RED	1
4 BARREL	BRASS	NICKEL	1
3 INSULATOR	PTFE	NATURAL	1
2 BODY	BRASS	NICKEL	1
1 HOUSING	BRASS	NICKEL	1

UNLESS OTHERWISE SPECIFIED DIMENSIONS ARE IN MILLIMETERS. DIMENSIONS IN [] ARE IN INCHES AND FOR CUSTOMER REFERENCE ONLY.

UNLESS OTHERWISE SPECIFIED TOLERANCES FOR MILLIMETERS ARE:
0.5 - 8mm ± 0.20mm
8 - 30mm ± 0.40mm
30 - 120mm ± 0.50mm

UNLESS OTHERWISE SPECIFIED TOLERANCES FOR INCHES ARE:
.020 - .315 = ± 0.007"
.315 - 1.180 = ± 0.015"
1.180 - 4.724 = ± 0.020"

DO NOT SCALE DRAWING

APPROVALS	DATE
DRAWN M.ZHANG	09/23/10
CHECKED	
ISSUED	
SHEET 1 OF 1	
CAD FILE C:/CONNEX/112505RP.DWG	

Amphenol Connex

PART DESCRIPTION
**BNC REVERSE BULKHEAD CRIMP JACK
(FOR RG-55/U,142A/U,223/U,400/U CABLE)**

PART NO.
112505RP

DWG. NO. 112505RP.DWG REV. B SIZE A SCALE NA