

LEGEND = KEY PRODUCT CHARACTERISTICS

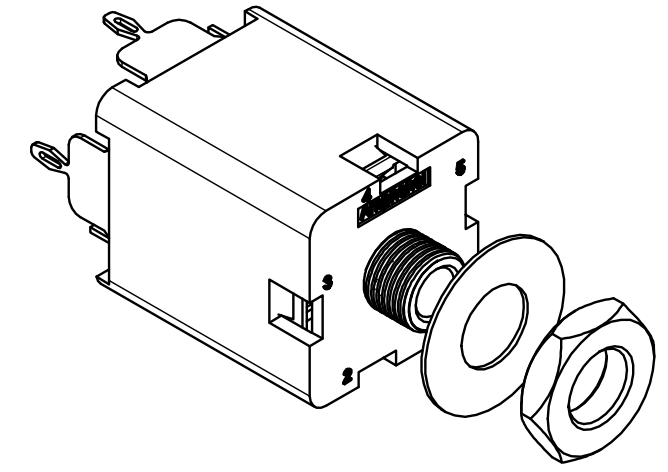

REVISION HISTORY				
REV	DESCRIPTION	DATE	BY	CHG/No
0	FIRST ISSUE	30/10/08	M.H	8798
1	ADD PCB LAYOUT ACC TO PART No	20/01/16	T.N	9330

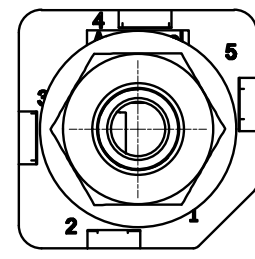
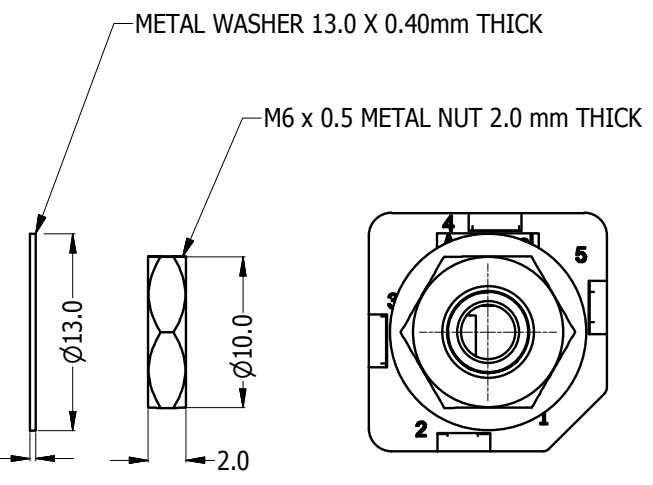
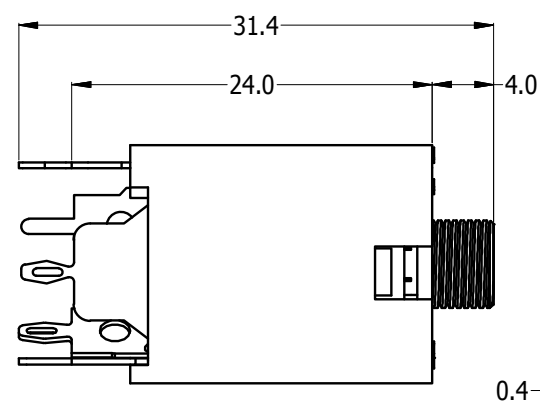
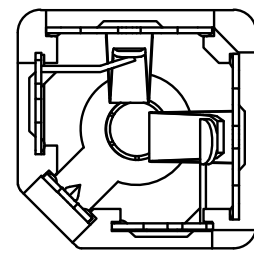

3D VIEW (2:1)

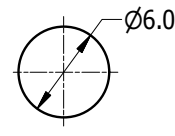

PANEL CUTOUT

PART NUMBER	ACJM-MV35-2	ACJM-MV35-2S	ACJS-MV35-3	ACJS-MV35-3S	ACJS-MV35-5
SCHEMATIC DIAGRAM					
PCB LAYOUT (CONNECTOR SIDE)					

NOTE: This connector is suitable for maximum 1.15mm panel thickness with Metal Washer & Nut

UNLESS OTHERWISE SPECIFIED TOLERANCE TO BE		THIS DOCUMENT IS THE PROPERTY OF AMPHENOL AUSTRALIA PTY. LTD. NO PART THEREOF MAY BE REPRODUCED AND USED WITHOUT THE PRIOR WRITTEN CONSENT OF THE OWNER				Amphenol Amphenol Australia Pty.Ltd, 22 Industry Boulevard, Carrum Downs, VIC 3201	
LINEAR	ANGULAR	MATERIAL: REFER TO COMPONENTS	DRN: B.Z	DATE: 25/04/08	TITLE: 3.5mm JACK VERTICAL CUSTOMER DRAWING		PART No: SEE CHART
X ±0.5	X' ±1	BREAK ALL SHARP EDGES AND REMOVE ALL BURRS	CKD: M.H	DATE: 29/10/08	DRAWING NO. 55010544-001-5		SHEET 1/1
X.X ±.1	X.X' ±.30'	DO NOT SCALE	APP'D: P.M	DATE: 29/10/08	CAD FILE 55010544001110		
X.XX ±.05	X.XX' ±.15'	DIMENSIONS IN MILLIMETRES	FINISH: REFER TO COMPONENTS	SCALE: NTS	SIZE: A3		