

*i*Coupler ADuM3221EBZ, 4 A Output-Isolated Gate Driver Evaluation Board

FEATURES

Isolated dual-channel gate driver with [ADuM3220/ADuM3221](#)
4 A peak output current
High frequency operation: 1 MHz maximum
CMOS input logic levels
2.5 kV rms isolation
Supports TO-263 or TO-252 IGBT/MOSFETs

SUPPORTED *i*Coupler® MODELS

[ADuM3220](#)
[ADuM3221](#)

GENERAL DESCRIPTION

The EVAL-ADuM3221EBZ supports the [ADuM3220/ADuM3221](#) isolated gate drivers. It is compatible with IGBT/MOSFETs in TO-263 or TO-252 packages. The evaluation board is ideal for evaluating the ADuM322x family with different power devices. It comes with an [ADuM3221A](#) installed.

EVALUATION BOARD

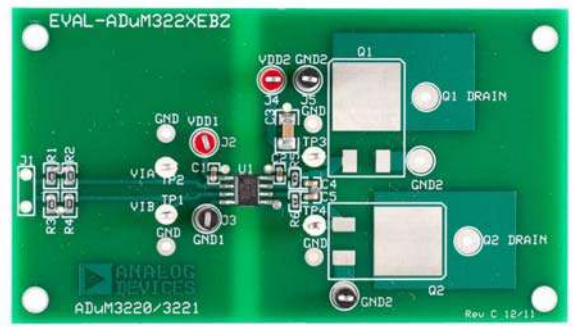

Figure 1. EVAL-ADuM3221EBZ Evaluation Board

TABLE OF CONTENTS

Features	1	Input Power Connections	3
Supported iCoupler® Models.....	1	Output Power Connections	3
General Description	1	I/O Connections.....	3
Evaluation Board	1	Evaluation Board Layout	4
Revision History	2	Ordering Information.....	5
Pad Layout for the DUT	3	Bill of Materials.....	5

REVISION HISTORY

3/12—Rev. 0 to Rev. A

Changes to User Guide Title, General Description Section, and Figure 1	1
Changes to Pad Layout for the DUT Section, Input Power Connections Section, Output Power Connections Section, I/O Connections Section, and Figure 3	3
Changes to Figure 4 and Figure 5.....	4
Added Ordering Information Section and Bill of Materials Section.....	5

2/11—Revision 0: Initial Version

PAD LAYOUT FOR THE DUT

Figure 4 and Figure 5 show the top and bottom layer artwork of the EVAL-ADuM3221EBZ evaluation board, respectively. Q1 and Q2 can be populated with TO-263 or TO-252 MOSFETs or IGBTs with the footprint shown in Figure 2. C4 and C5 are 2.2 nF and represent a typical gate capacitance. If MOSFETs/IGBTs are soldered to Q1 and Q2, remove these capacitors. R5 and R6 add resistance in series with the gates to control the edges of the gate driver. If the outputs have a lighter load than 2 nF, the resistance of R5 and R6 may need to be increased.

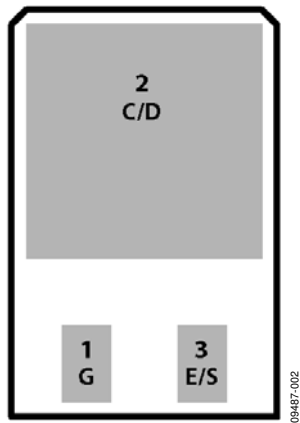

Figure 2. IGBT/MOSFET Footprint

INPUT POWER CONNECTIONS

Connect the input side supply, VDD1 (3 V to 5.5 V) to J2 and its return to J3 (GND1).

OUTPUT POWER CONNECTIONS

Connect the output supply voltage, VDD2 (4.5 V to 18 V) of the [ADuM3220/ADuM3221](#) to J4 and its return to J5 (GND2).

I/O CONNECTIONS

Connect Logic Input A/VIA and Logic Input B/VIB to an external logic signal via J1 or TP1/TP2. The two logic inputs have 50 Ω terminations. The collector/drain outputs of the two IGBTs/MOSFETs, Q1 and Q2, have labeled wire pads.

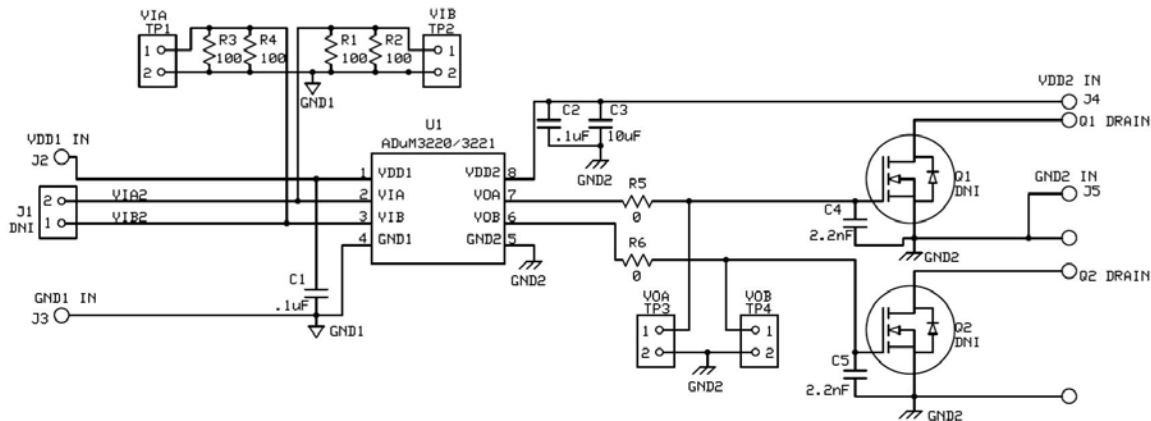

Figure 3. ADuM3220/ADuM3221 Schematic

EVALUATION BOARD LAYOUT

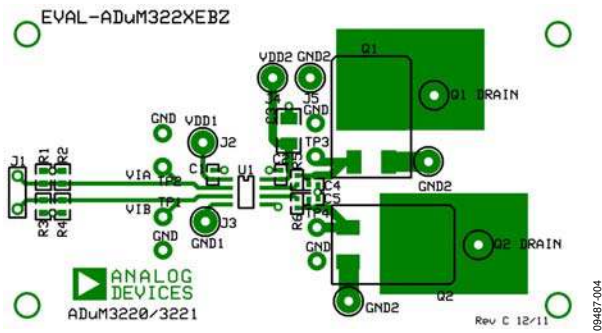

Figure 4. Top Layer of the EVAL-ADuM3221EBZ Evaluation Board

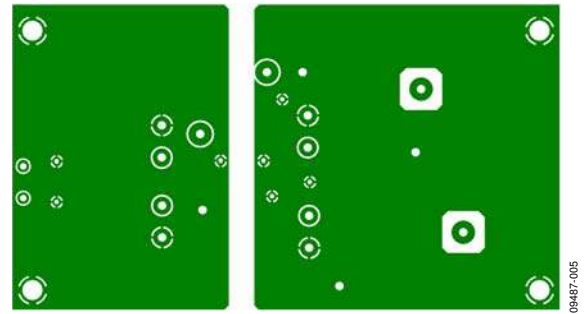

Figure 5. Bottom Layer of the EVAL-ADuM3221EBZ Evaluation Board

ORDERING INFORMATION**BILL OF MATERIALS**

Table 1.

Quantity	Reference Designator	Description
1	U1	ADuM3221A
4	R1 to R4	100 Ω , 1/4 W, 1%, 0805
2	R5, R6	0 Ω , 1/10 W, 0603
2	C1, C2	0.1 μ F, 25 V, 10%, 0603
1	C3	10 μ F, 25 V, 10%, 1206
2	C4, C5	2200 pF, 50 V, 5%, 0603
2	J3, J5	TP-104 series test point, black
2	J2, J4	TP-104 series test point, red
4	TP1 to TP4	TP-104 series test point, white
Not applicable	J1, Q1, Q2	Do not install

NOTES

NOTES

NOTES

**ESD Caution**

ESD (electrostatic discharge) sensitive device. Charged devices and circuit boards can discharge without detection. Although this product features patented or proprietary protection circuitry, damage may occur on devices subjected to high energy ESD. Therefore, proper ESD precautions should be taken to avoid performance degradation or loss of functionality.

Legal Terms and Conditions

By using the evaluation board discussed herein (together with any tools, components documentation or support materials, the "Evaluation Board"), you are agreeing to be bound by the terms and conditions set forth below ("Agreement") unless you have purchased the Evaluation Board, in which case the Analog Devices Standard Terms and Conditions of Sale shall govern. Do not use the Evaluation Board until you have read and agreed to the Agreement. Your use of the Evaluation Board shall signify your acceptance of the Agreement. This Agreement is made by and between you ("Customer") and Analog Devices, Inc. ("ADI"), with its principal place of business at One Technology Way, Norwood, MA 02062, USA. Subject to the terms and conditions of the Agreement, ADI hereby grants to Customer a free, limited, personal, temporary, non-exclusive, non-sublicensable, non-transferable license to use the Evaluation Board FOR EVALUATION PURPOSES ONLY. Customer understands and agrees that the Evaluation Board is provided for the sole and exclusive purpose referenced above, and agrees not to use the Evaluation Board for any other purpose. Furthermore, the license granted is expressly made subject to the following additional limitations: Customer shall not (i) rent, lease, display, sell, transfer, assign, sublicense, or distribute the Evaluation Board; and (ii) permit any Third Party to access the Evaluation Board. As used herein, the term "Third Party" includes any entity other than ADI, Customer, their employees, affiliates and in-house consultants. The Evaluation Board is NOT sold to Customer; all rights not expressly granted herein, including ownership of the Evaluation Board, are reserved by ADI. CONFIDENTIALITY. This Agreement and the Evaluation Board shall all be considered the confidential and proprietary information of ADI. Customer may not disclose or transfer any portion of the Evaluation Board to any other party for any reason. Upon discontinuation of use of the Evaluation Board or termination of this Agreement, Customer agrees to promptly return the Evaluation Board to ADI. ADDITIONAL RESTRICTIONS. Customer may not disassemble, decompile or reverse engineer chips on the Evaluation Board. Customer shall inform ADI of any occurred damages or any modifications or alterations it makes to the Evaluation Board, including but not limited to soldering or any other activity that affects the material content of the Evaluation Board. Modifications to the Evaluation Board must comply with applicable law, including but not limited to the RoHS Directive. TERMINATION. ADI may terminate this Agreement at any time upon giving written notice to Customer. Customer agrees to return to ADI the Evaluation Board at that time. LIMITATION OF LIABILITY. THE EVALUATION BOARD PROVIDED HEREUNDER IS PROVIDED "AS IS" AND ADI MAKES NO WARRANTIES OR REPRESENTATIONS OF ANY KIND WITH RESPECT TO IT. ADI SPECIFICALLY DISCLAIMS ANY REPRESENTATIONS, ENDORSEMENTS, GUARANTEES, OR WARRANTIES, EXPRESS OR IMPLIED, RELATED TO THE EVALUATION BOARD INCLUDING, BUT NOT LIMITED TO, THE IMPLIED WARRANTY OF MERCHANTABILITY, TITLE, FITNESS FOR A PARTICULAR PURPOSE OR NON-INFRINGEMENT OF INTELLECTUAL PROPERTY RIGHTS. IN NO EVENT WILL ADI AND ITS LICENSORS BE LIABLE FOR ANY INCIDENTAL, SPECIAL, INDIRECT, OR CONSEQUENTIAL DAMAGES RESULTING FROM CUSTOMER'S POSSESSION OR USE OF THE EVALUATION BOARD, INCLUDING BUT NOT LIMITED TO LOST PROFITS, DELAY COSTS, LABOR COSTS OR LOSS OF GOODWILL. ADI'S TOTAL LIABILITY FROM ANY AND ALL CAUSES SHALL BE LIMITED TO THE AMOUNT OF ONE HUNDRED US DOLLARS (\$100.00). EXPORT. Customer agrees that it will not directly or indirectly export the Evaluation Board to another country, and that it will comply with all applicable United States federal laws and regulations relating to exports. GOVERNING LAW. This Agreement shall be governed by and construed in accordance with the substantive laws of the Commonwealth of Massachusetts (excluding conflict of law rules). Any legal action regarding this Agreement will be heard in the state or federal courts having jurisdiction in Suffolk County, Massachusetts, and Customer hereby submits to the personal jurisdiction and venue of such courts. The United Nations Convention on Contracts for the International Sale of Goods shall not apply to this Agreement and is expressly disclaimed.