

PANEL THICKNESS AND HARDWARE INSTALLATION

PANEL THICKNESS	W07 - LARGE SHOULDER NUT									W11 - SMALL SHOULDER NUT						
	0.050	0.055	0.060	0.065	0.070	0.075	0.080	0.085	0.090	0.095	0.100	0.105	0.110	0.115	0.120	0.125
WASHER (K178)	YES	YES	YES	YES	YES	NO	NO	NO	NO	YES	YES	YES	YES	YES	NO	NO

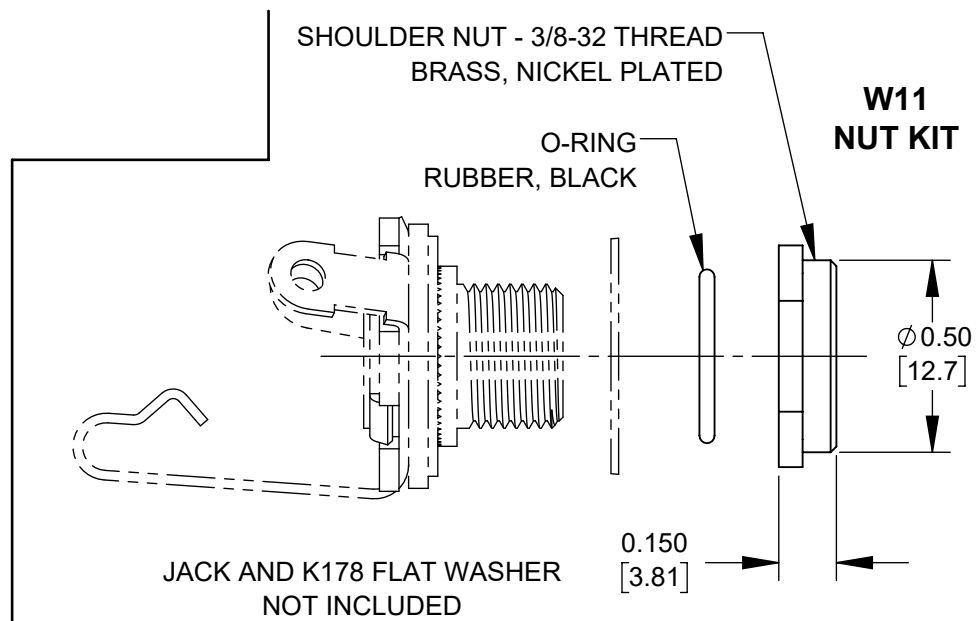
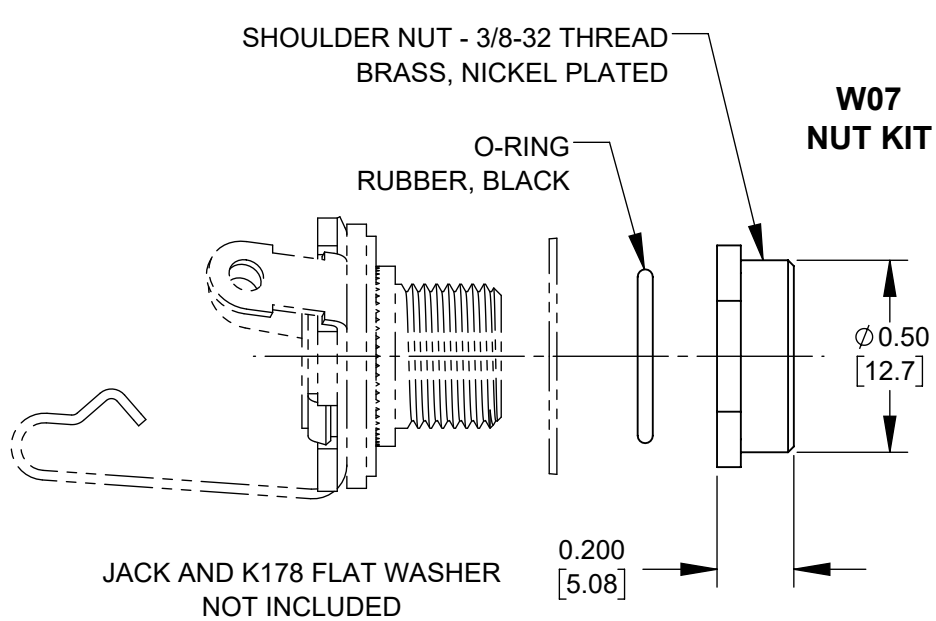

- NOTES:**
- JACK SEAL KIT TO BE USED WITH SWITCHCRAFT Ø 1/4" OPEN FRAME JACKS.
EXAMPLES - 11, 12A & 12B JACKS
 - IP66 RATED WHEN MATED WITH 250S15-S28 OR 267S15-S28 SERIES PLUGS.

CUSTOMER DRAWING

					THIS DRAWING DESCRIBES A DESIGN CONSIDERED PROPRIETARY IN NATURE, DEVELOPED AND MANUFACTURED BY SWITCHCRAFT INC. AND IS RELEASED ON A CONFIDENTIAL BASIS FOR IDENTIFICATION PURPOSES ONLY.						
					SIZE	WIDTH	MULT	LBS/M	TEMPER		
					UNLESS OTHERWISE SPECIFIED			FINISH			
					1. ALL DIMENSIONS IN INCHES [mm]			MATERIAL			
					- TWO PLACE DECIMALS ±0.02 [0.5]			SPEC No.			
					- THREE PLACE DECIMALS ±0.005 [0.13]			SCALE			
					FIRST USED ON		2:1				
A	28492	5/18/22	TJK	TJK	DATE DRAWN	BY	CHKD	APVD	Switchcraft®		
REV	ECO NUMBER	DATE	BY	APVD	3/23/22	TJK	TJK	TJK			
REVISIONS					DO NOT SCALE DRAWING					SHEET 1 OF 1	
					NAME SHOULDER NUT KIT FOR Ø 1/4" SEALED JACKS, RoHS					PART No. W07-W11	
										REV A	