

Type N Straight Plug Crimp Style for RG-58, 142, 213, 214 and LMR-400 Flexible Cable

1. Identify connector parts. (3 piece parts)
2. Strip cable to dimensions shown. Do not nick center conductor. A wire stripper of correct size is recommended for this step. Tin center conductor if contact will be solder attached. Do not tin center conductor if contact will be crimp attached. Slide crimp sleeve onto jacket of cable.
3. Assemble plug contact onto cable as shown. Plug contact should butt against cable dielectric during attachment. Solder Attachment: Solder plug contact to center conductor through solder hole using .020 (.051) diameter flux core solder wire. Use a minimum amount of solder for a good joint. Crimp Attachment: Crimp plug contact to center conductor using Johnson ergonomic hand crimp frame 140-0000-967 with recommended hex size die set. Crimp location should be on end of plug contact next to cable dielectric. Crimp attachment to solid center conductor cables is not recommended.
4. Flare braid and slide plug connector assembly over plug contact and under braid. Seat plug connector assembly firmly onto contact. Arrange braid uniformly around crimp stem. Slide crimp sleeve forward and crimp using Johnson ergonomic hand crimp frame 140-0000-967 with recommended hex size die set. Maintain forward pressure on cable while crimping.

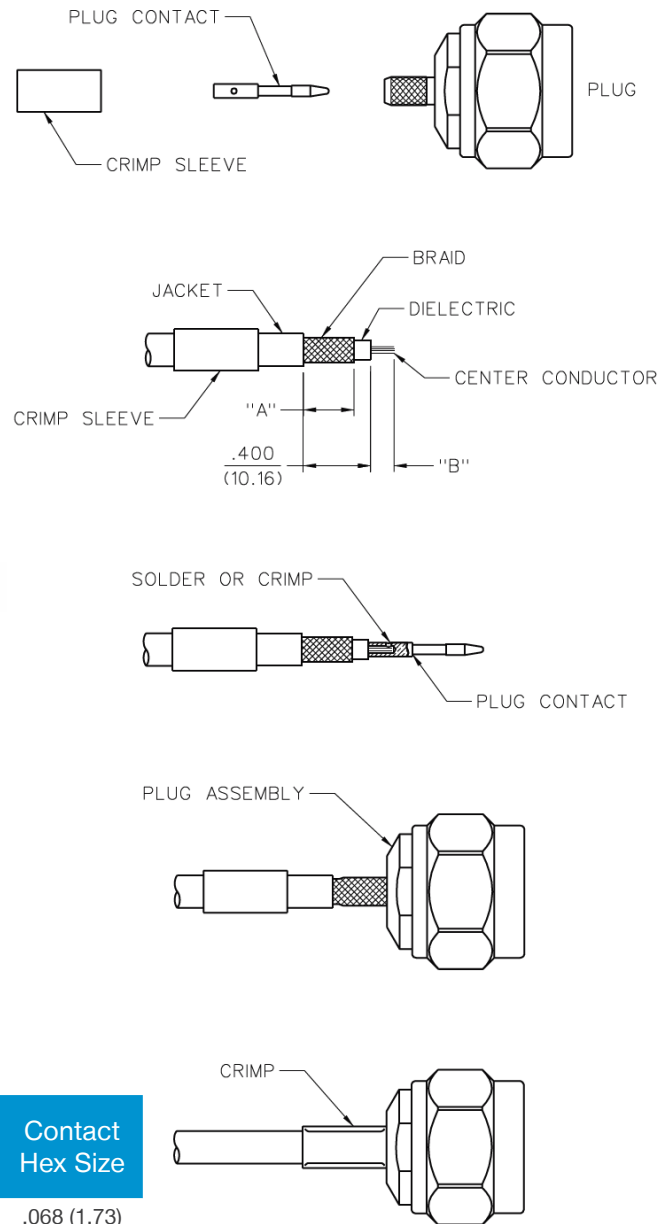

Cable Group	Part No.	"A"	"B"	Crimp Sleeve Hex Size	Contact Hex Size
RG-58/U, 141, 303	138-4407-007	.301 (7.65)	.140 (3.56)	.213 (5.41)	.068 (1.73)
RG-55/U, 142, 223, 400	138-4408-007	.301 (7.65)	.140 (3.56)	.213 (5.41)	.068 (1.73)
RG-8, 213	138-4416-007	.385 (9.78)	.170 (4.32)	.429 (10.90)	.111 (2.82)
RG-9, 214	138-4418-007	.385 (9.78)	.170 (4.32)	.429 (10.90)	.111 (2.82)
LMR-400, BELDEN 9913	138-4449-007	.385 (9.78)	.170 (4.32)	.429 (10.90)	.116 (2.95)

Assembly		
Tool	138-4407/4408-007	138-4416/4418/4449-007
Crimp Frame	140-0000-967	140-0000-967
Die Set	140-0000-990	140-0000-991

