

Product Specification

NHD-C0216CiZ-FN-FBW-3V

COG (Chip-on-Glass) Liquid Crystal Display Module

NHD-	Newhaven Display
C0216-	COG, 2 lines x 16 characters
CiZ-	Model
F-	Transflective
N-	No LED Backlight
B-	6:00 View Angle
W-	Wide Temperature (-20C to +70C)
3V-	3 Volt

Table of Contents

Document Revision History	2
Functions and Features	2
Mechanical Drawing	3
Pin Description	4
Driver Information	5
Electrical Characteristics	5
Optical Characteristics	5
Table of commands	7
Timing Characteristics	8
Built-in Font Table	9
Quality Information	12

Additional Resources

- **Support Forum:** <http://www.nhdforum.newhavendisplay.com>
- **Github:** <https://github.com/newhavendisplay>
- **Example Code:** https://www.newhavendisplay.com/example_code.html
- **Knowledge Center:** https://www.newhavendisplay.com/knowledge_center.html
- **Quality Center:** https://www.newhavendisplay.com/quality_center.html
- **Precautions for using LCDs/LCMs:** <https://www.newhavendisplay.com/specs/precautions.pdf>
- **Warranty / Terms & Conditions:** <https://www.newhavendisplay.com/terms.html>



Document Revision History

Revision	Date	Description	Changed By
0	3/10/2000	Initial Release	-
1	5/14/2009	User Guide Reformat	BE
2	10/9/2009	Updated Electrical Characteristics	MC
3	11/5/2009	Block Diagram Update	BE
4	2/12/2010	Update Font Table	MC
5	11/2/2010	Slave Address Corrected	SB
6	3/30/2012	Example Initialization Program Updated	AK
7	7/5/2019	Added PCB Footprint Drawing	AS
8	10/23/2020	Updated Symbol for LCD Supply Voltage	AS
9	7/13/2021	IC Updated	ZP

Functions and Features

- 2 lines x 16 characters
- Built-in AiP31032 IC with I2C Interface
- Built-in DC supply for VLCD (requires 2 external capacitors)
- 5x8 dots with cursor
- 3.0V power supply
- 1/16 duty, 1/5 bias
- RoHS Compliant

Mechanical Drawing

SYMBOL	REVISION	DATE

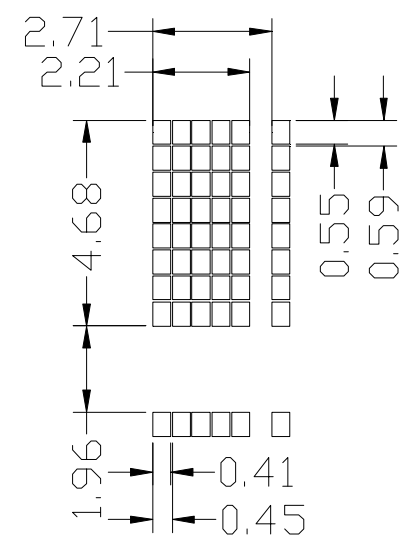
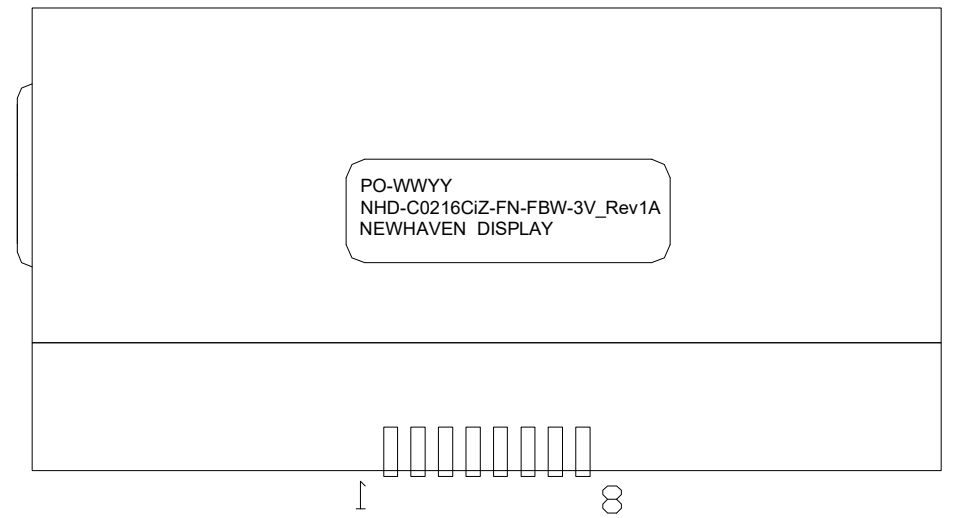
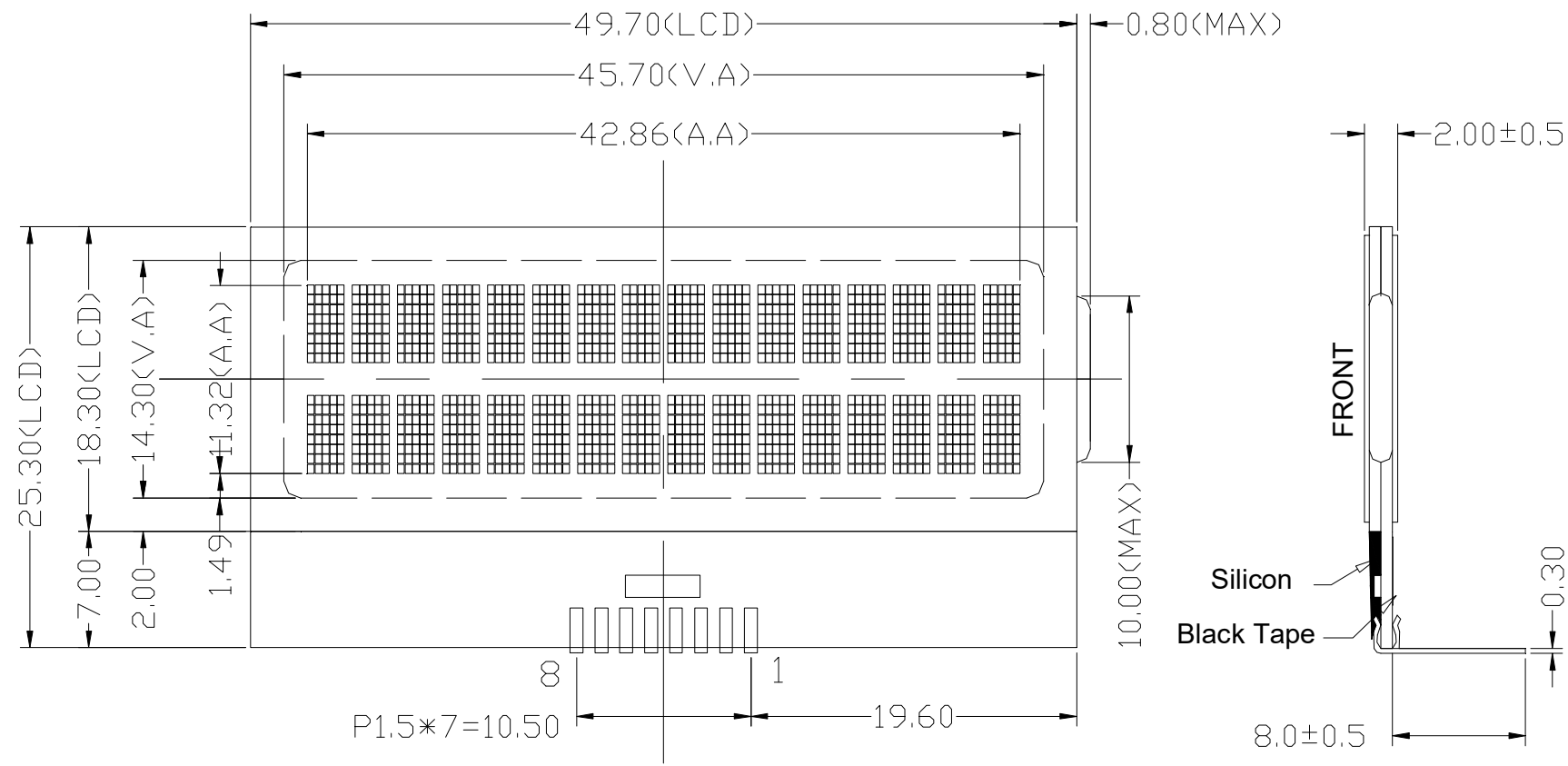

DETAIL:DOTS
 SCALE: 2:1

PIN CONNECTION	
NO	SYMBOL
1	REST
2	SCL
3	SDA
4	VSS
5	VDD
6	VOUT
7	C1+
8	C1-

- Notes:
- 1). Driver Method: 1/16 Duty, 1/5 Bias, VDD=3.0V, VLCD=5.0V
 - 2). Display Type: FSTN(+) Transflective
 - 3). Viewing Angle: 6:00
 - 4). Operating Temperature: -20C to +70C
 - 5). Storage Temperature: -30C to +80C
 - 6). Driver: AIP31032-I2C Interface
 - 7). RoHS Compliant

Standard Tolerance: (Unless otherwise specified) Linear: ±0.3mm		
	Drawing/Part Number: NHD-C0216CiZ-FN-FBW-3V	Revision: 1A
Unless otherwise specified: • Dimensions are in Millimeters • Third Angle Projection	Drawn By: Z.Palrang	Approved By: Z.Palrang
	Drawn Date: 07/13/2021	Approved Date: 07/13/2021
Do Not Scale Drawing		Sheet 1 of 1
This drawing is solely the property of Newhaven Display International, Inc. The information it contains is not to be disclosed, reproduced or copied in whole or part without written approval from Newhaven Display.		

Pin Description and Wiring Diagram

Pin No.	Symbol	External Connection	Function Description
1	RST	MPU	Active low Reset
2	SCL	MPU	Serial clock (requires pull-up resistor)
3	SDA	MPU	Serial Data (requires pull-up resistor)
4	Vss	Power Supply	Ground
5	VDD	Power Supply	+3.0V
6	VOUT	CAP	Voltage booster circuit– connect to 1uF cap to Vss or VDD
7	C1+	CAP	Connect to 1uF cap to PIN8
8	C1-	CAP	Connect to 1uF cap to PIN7

Recommended LCD connector: 1.5mm pitch pins

Backlight connector: - Mates with: -

Recommended Breakout Board: [NHD-PCB40](#)

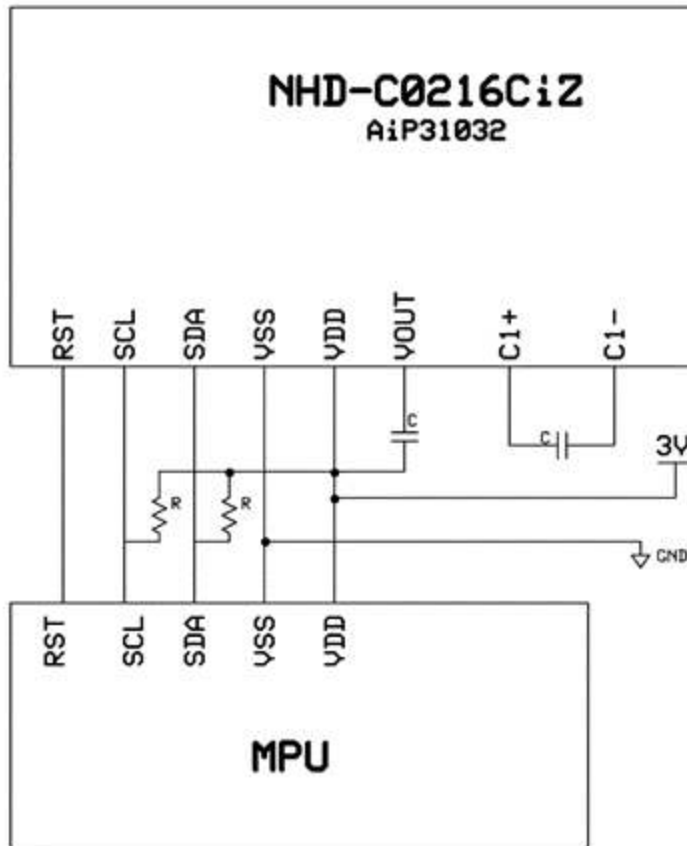

Electrical Characteristics

Item	Symbol	Condition	Min.	Typ.	Max.	Unit
Operating Temperature Range	Top	Absolute Max	-20	-	+70	°C
Storage Temperature Range	Tst	Absolute Max	-30	-	+80	°C
Supply Voltage	VDD		2.7	3.0	3.3	V
Supply Current	IDD	Ta=25°C, VDD=3.0V	-	0.3	0.5	mA
Supply for LCD (contrast)	V _{LCD}	V ₀ -V _{SS} , Ta=25°C	4.8	5.0	5.2	V
"H" Level input	V _{IH}		2.2	-	VDD	V
"L" Level input	V _{IL}		0	-	0.6	V
"H" Level output	V _{OH}		2.4	-	-	V
"L" Level output	V _{OL}		-	-	0.4	V

Optical Characteristics:

Item	Symbol	Condition	Min.	Typ.	Max.	Unit
Optimal Viewing Angles	Top	CR ≥ 2	30	40	-	°
	Bottom		50	60	-	°
	Left		50	60	-	°
	Right		50	60	-	°
Contrast Ratio	CR	-	2	5	-	-
Response Time (Rise)	T _R	T _{OP} = 25°C	-	150	250	ms
Response Time (Fall)	T _F		-	200	300	ms

Controller Information:

Built-in AiP31032 Controller.

Please download specification at

https://www.newhavendisplay.com/resources_dataFiles/datasheets/LCDs/AiP31032.pdf



Slave Address = 0x7C

Write mode

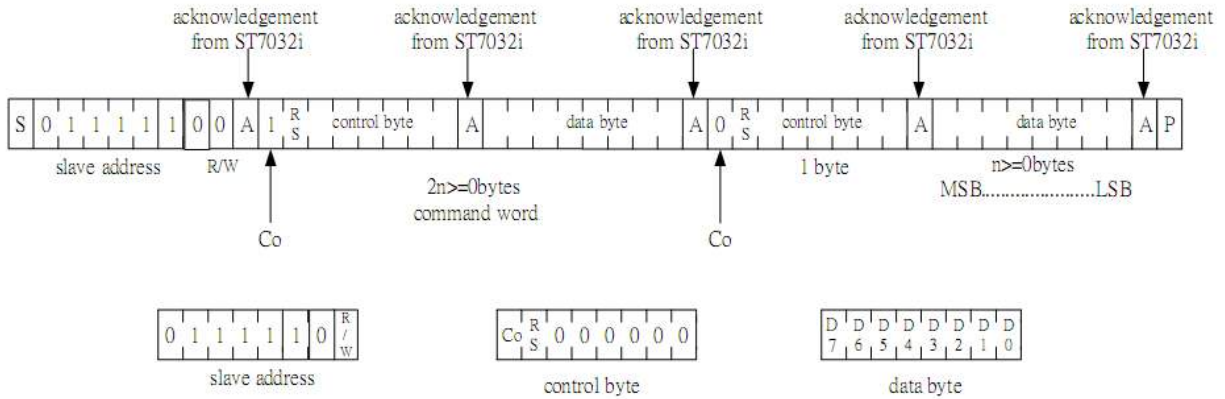
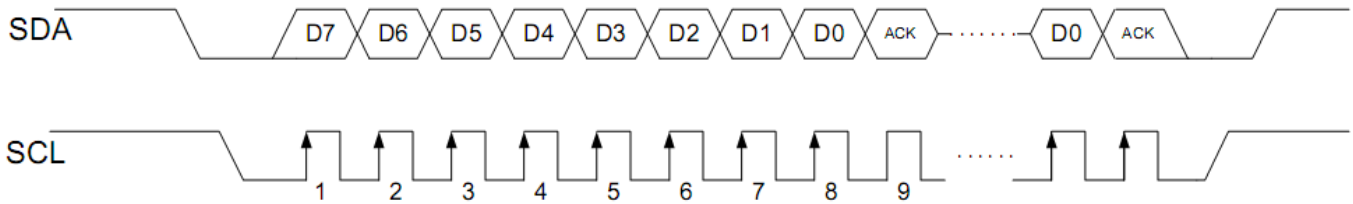

Figure 5. 2-line Interface protocol

Co	0	Last control byte to be sent. Only a stream of data bytes is allowed to follow. This stream may only be terminated by a STOP condition.
	1	Another control byte will follow the data byte unless a STOP condition is received.



Display Position	1	2	3	4	5	6	38	39	40
DDRAM Address (hexadecimal)	00	01	02	03	04	05	25	26	27
	40	41	42	43	44	45	65	66	67

Table of Commands

➤ instruction table at "Extension mode"

(when "EXT" option pin connect to VSS, the instruction set follow below table)

Instruction	Instruction Code										Description	Instruction Execution Time			
	RS	R/W	DB7	DB6	DB5	DB4	DB3	DB2	DB1	DB0		OSC=380KHz	OSC=540kHz	OSC=700KHz	
Clear Display	0	0	0	0	0	0	0	0	0	1	Write "20H" to DDRAM. and set DDRAM address to "00H" from AC	1.08 ms	0.76 ms	0.59 ms	
Return Home	0	0	0	0	0	0	0	0	0	1	x	Set DDRAM address to "00H" from AC and return cursor to its original position if shifted. The contents of DDRAM are not changed.	1.08 ms	0.76 ms	0.59 ms
Entry Mode Set	0	0	0	0	0	0	0	0	1	I/D	S	Sets cursor move direction and specifies display shift. These operations are performed during data write and read.	26.3 us	18.5 us	14.3 us
Display ON/OFF	0	0	0	0	0	0	0	1	D	C	B	D=1:entire display on C=1:cursor on B=1:cursor position on	26.3 us	18.5 us	14.3 us
Function Set	0	0	0	0	1	DL	N	DH	*0		IS	DL: interface data is 8/4 bits N: number of line is 2/1 DH: double height font IS: instruction table select	26.3 us	18.5 us	14.3 us
Set DDRAM address	0	0	1	AC6	AC5	AC4	AC3	AC2	AC1	AC0		Set DDRAM address in address counter	26.3 us	18.5 us	14.3 us

Instruction table 0(IS=0)

Cursor or Display Shift	0	0	0	0	0	1	S/C	R/L	x	x	S/C and R/L: Set cursor moving and display shift control bit, and the direction, without changing DDRAM data.	26.3 us	18.5 us	14.3 us
Set CGRAM	0	0	0	1	AC5	AC4	AC3	AC2	AC1	AC0	Set CGRAM address in address counter	26.3 us	18.5 us	14.3 us

Instruction table 1(IS=1)

Internal OSC frequency	0	0	0	0	0	1	BS	F2	F1	F0	BS=1:1/4 bias BS=0:1/5 bias F2~0: adjust internal OSC frequency for FR frequency.	26.3 us	18.5 us	14.3 us
Set ICON address	0	0	0	1	0	0	AC3	AC2	AC1	AC0	Set ICON address in address counter.	26.3 us	18.5 us	14.3 us
Power/ICON control/Contrast set	0	0	0	1	0	1	Ion	Bon	C5	C4	Ion: ICON display on/off Bon: set booster circuit on/off C5,C4: Contrast set for internal follower mode.	26.3 us	18.5 us	14.3 us
Follower control	0	0	0	1	1	0	Fon	Rab2	Rab1	Rab0	Fon: set follower circuit on/off Rab2~0: select follower amplified ratio.	26.3 us	18.5 us	14.3 us
Contrast set	0	0	0	1	1	1	C3	C2	C1	C0	Contrast set for internal follower mode.	26.3 us	18.5 us	14.3 us

Timing Characteristics

(Ta = -30°C to 85°C)

Item	Signal	Symbol	Condition	VDD=2.7 to 4.5V Rating		VDD=4.5 to 5.5V Rating		Units
				Min.	Max.	Min.	Max.	
SCL clock frequency	SCL	f_{SCLK}	—	DC	400	DC	400	KHz
SCL clock low period		t_{LOW}		1.3	—	1.3	—	us
SCL clock high period		t_{HIGH}		0.6	—	0.6	—	
Data set-up time	SI	$t_{SU:DAT}$	—	180	—	100	—	ns
Data hold time		$t_{HD:DAT}$		0	0.9	0	0.9	us
SCL,SDA rise time	SCL, SDA	t_r	—	$20+0.1C_b$	300	$20+0.1C_b$	300	ns
SCL,SDA fall time		t_f		$20+0.1C_b$	300	$20+0.1C_b$	300	
Capacitive load represent by each bus line		C_b	—	—	400	—	400	pf
Setup time for a repeated START condition	SI	$t_{SU:STA}$	—	0.6	—	0.6	—	us
Start condition hold time		$t_{HD:STA}$	—	0.6	—	0.6	—	us
Setup time for STOP condition		$t_{SU:STO}$	—	0.6	—	0.6	—	us
Bus free time between a Stop and START condition	SCL	t_{BUF}	—	1.3	—	1.3	—	us

- I2C interface

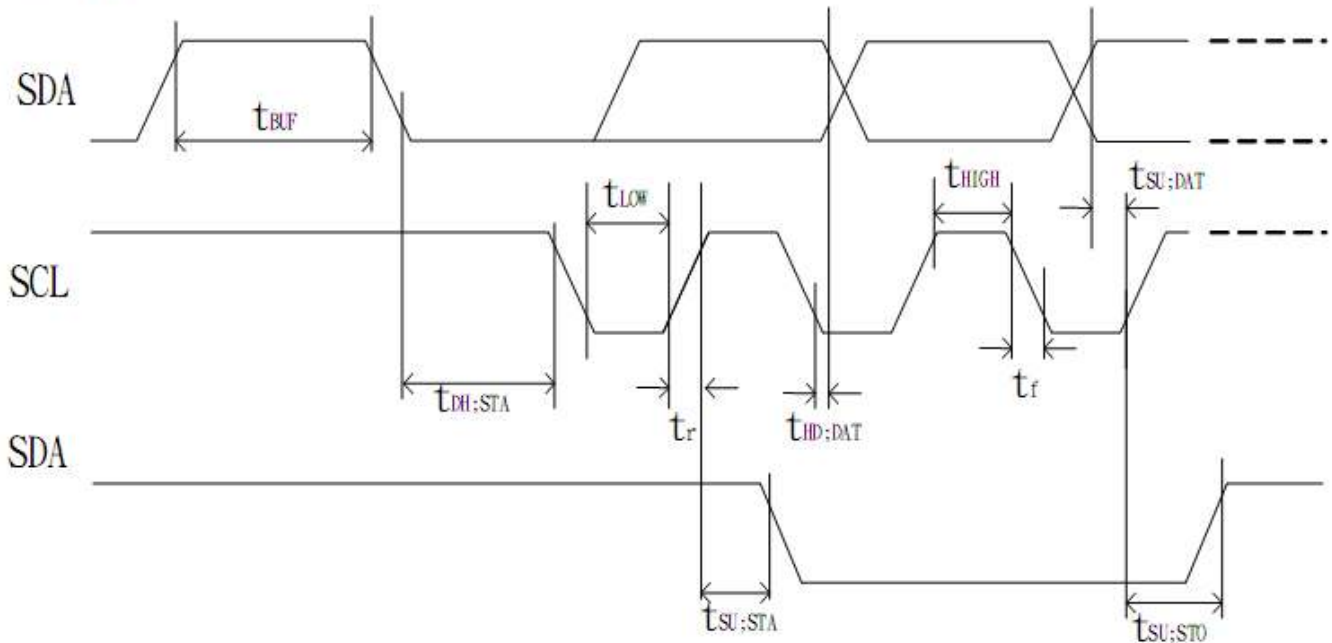

Built-in Font Table

OPR1, OPR2 = (0,0)

b7-b4 b3-b0	0000	0001	0010	0011	0100	0101	0110	0111	1000	1001	1010	1011	1100	1101	1110	1111
0000	À	Á	Â	Ã	Ä	Å	Æ	Ç	È	É	Ê	Ë	Ì	Í	Î	Ï
0001	Ð	Ñ	Ò	Ó	Ô	Õ	Ö	×	Ø	Ù	Ú	Û	Ü	Ý	Þ	ß
0010	à	á	â	ã	ä	å	æ	ç	è	é	ê	ë	ì	í	î	ï
0011	ð	ñ	ò	ó	ô	õ	ö	÷	ø	ù	ú	û	ü	ý	þ	ÿ
0100	ƒ	€	ƒ	ƒ	ƒ	ƒ	ƒ	ƒ	ƒ	ƒ	ƒ	ƒ	ƒ	ƒ	ƒ	ƒ
0101	ƒ	ƒ	ƒ	ƒ	ƒ	ƒ	ƒ	ƒ	ƒ	ƒ	ƒ	ƒ	ƒ	ƒ	ƒ	ƒ
0110	ƒ	ƒ	ƒ	ƒ	ƒ	ƒ	ƒ	ƒ	ƒ	ƒ	ƒ	ƒ	ƒ	ƒ	ƒ	ƒ
0111	ƒ	ƒ	ƒ	ƒ	ƒ	ƒ	ƒ	ƒ	ƒ	ƒ	ƒ	ƒ	ƒ	ƒ	ƒ	ƒ
1000	ƒ	ƒ	ƒ	ƒ	ƒ	ƒ	ƒ	ƒ	ƒ	ƒ	ƒ	ƒ	ƒ	ƒ	ƒ	ƒ
1001	ƒ	ƒ	ƒ	ƒ	ƒ	ƒ	ƒ	ƒ	ƒ	ƒ	ƒ	ƒ	ƒ	ƒ	ƒ	ƒ
1010	ƒ	ƒ	ƒ	ƒ	ƒ	ƒ	ƒ	ƒ	ƒ	ƒ	ƒ	ƒ	ƒ	ƒ	ƒ	ƒ
1011	ƒ	ƒ	ƒ	ƒ	ƒ	ƒ	ƒ	ƒ	ƒ	ƒ	ƒ	ƒ	ƒ	ƒ	ƒ	ƒ
1100	ƒ	ƒ	ƒ	ƒ	ƒ	ƒ	ƒ	ƒ	ƒ	ƒ	ƒ	ƒ	ƒ	ƒ	ƒ	ƒ
1101	ƒ	ƒ	ƒ	ƒ	ƒ	ƒ	ƒ	ƒ	ƒ	ƒ	ƒ	ƒ	ƒ	ƒ	ƒ	ƒ
1110	ƒ	ƒ	ƒ	ƒ	ƒ	ƒ	ƒ	ƒ	ƒ	ƒ	ƒ	ƒ	ƒ	ƒ	ƒ	ƒ
1111	ƒ	ƒ	ƒ	ƒ	ƒ	ƒ	ƒ	ƒ	ƒ	ƒ	ƒ	ƒ	ƒ	ƒ	ƒ	ƒ

Replaced By CGRAM Pattern

Example Initialization Program

```

/*****/
void I2C_out(unsigned char j)           //I2C Output
{
    int n;
    unsigned char d;
    d=j;
    for(n=0;n<8;n++){
        if((d&0x80)==0x80)
            SDA=1;
        else
            SDA=0;
        d=(d<<1);
        SCL = 0;
        SCL = 1;
        SCL = 0;
    }
    SCL = 1;
    while(SDA==1){
        SCL=0;
        SCL=1;
    }
    SCL=0;
}
/*****/
void I2C_Start(void)
{
    SCL=1;
    SDA=1;
    SDA=0;
    SCL=0;
}
/*****/
void I2C_Stop(void)
{
    SDA=0;
    SCL=0;
    SCL=1;
    SDA=1;
}
/*****/
void Show(unsigned char *text)
{
    int n;
    I2C_Start();
    I2C_out(Slave);
    I2C_out(Datasend);
    for(n=0;n<16;n++){
        I2C_out(*text);
        ++text;
    }
    I2C_Stop();
}
/*****/

```

```
*****/  
void init_LCD()  
{  
I2C_Start();  
I2C_out(0x7C);  
I2C_out(0x00);  
I2C_out(0x38);  
delay(10);  
I2C_out(0x39);  
delay(10);  
I2C_out(0x14);  
I2C_out(0x78);  
I2C_out(0x5E);  
I2C_out(0x6D);  
I2C_out(0x0C);  
I2C_out(0x01);  
I2C_out(0x06);  
delay(10);  
I2C_stop();  
}  
*****/
```

Quality Information

Test Item	Content of Test	Test Condition	Note
High Temperature storage	Endurance test applying the high storage temperature for a long time.	+80°C , 48hrs	2
Low Temperature storage	Endurance test applying the low storage temperature for a long time.	-30°C , 48hrs	1,2
High Temperature Operation	Endurance test applying the electric stress (voltage & current) and the high thermal stress for a long time.	+70°C , 48hrs	2
Low Temperature Operation	Endurance test applying the electric stress (voltage & current) and the low thermal stress for a long time.	-20°C , 48hrs	1,2
High Temperature / Humidity Operation	Endurance test applying the electric stress (voltage & current) and the high thermal with high humidity stress for a long time.	+40°C , 90% RH , 48hrs	1,2
Thermal Shock resistance	Endurance test applying the electric stress (voltage & current) during a cycle of low and high thermal stress.	0°C,30min -> 25°C,5min -> 50°C,30min = 1 cycle 10 cycles	
Vibration test	Endurance test applying vibration to simulate transportation and use.	10-55Hz , 15mm amplitude. 60 sec in each of 3 directions X,Y,Z For 15 minutes	3
Static electricity test	Endurance test applying electric static discharge.	VS=800V, RS=1.5kΩ, CS=100pF One time	

Note 1: No condensation to be observed.

Note 2: Conducted after 4 hours of storage at 25°C, 0%RH.

Note 3: Test performed on product itself, not inside a container.

Precautions for using LCDs/LCMs

See Precautions at www.newhavendisplay.com/specs/precautions.pdf

Warranty Information and Terms & Conditions

http://www.newhavendisplay.com/index.php?main_page=terms

