

HiPerFET™ Power MOSFETs IXFL 39N90

ISOPLUS264™

(Electrically Isolated Backside)

Single Die MOSFET

N-Channel Enhancement Mode

Avalanche Rated, High dv/dt, Low t_{rr}

Preliminary Data Sheet

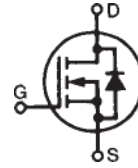

$$V_{DSS} = 900 \text{ V}$$

$$I_{D25} = 34 \text{ A}$$

$$R_{DS(on)} = 220 \text{ m}\Omega$$

$$t \leq \text{ns}$$

Symbol	Test Conditions	Maximum Ratings	
V_{DSS}	$T_J = 25^\circ\text{C}$ to 150°C	900	V
V_{DGR}	$T_J = 25^\circ\text{C}$ to 150°C ; $R_{GS} = 1 \text{ M}\Omega$	900	V
V_{GS}	Continuous	± 20	V
V_{GSM}	Transient	± 30	V
I_{D25}	$T_C = 25^\circ\text{C}$, Chip capability	34	A
I_{DM}	$T_C = 25^\circ\text{C}$, Note 1	154	A
I_{AR}	$T_C = 25^\circ\text{C}$	39	A
E_{AR}	$T_C = 25^\circ\text{C}$	64	mJ
E_{AS}	$T_C = 25^\circ\text{C}$	4	J
dv/dt	$I_S \leq I_{DM}$, $di/dt \leq 100 \text{ A}/\mu\text{s}$, $V_{DD} \leq V_{DSS}$ $T_J \leq 150^\circ\text{C}$, $R_G = 2 \Omega$	5	V/ns
P_D	$T_C = 25^\circ\text{C}$	580	W
T_J		-40 ... +150	$^\circ\text{C}$
T_{JM}		150	$^\circ\text{C}$
T_{stg}		-40 ... +150	$^\circ\text{C}$
V_{ISOL}	50/60 Hz, RMS $t = 1 \text{ min}$ $I_{ISOL} \leq 1 \text{ mA}$ $t = 1 \text{ s}$	2500 3000	V~ V~
Weight		8	g

ISOPLUS-264™

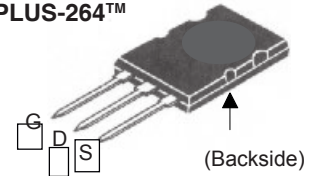

G = Gate D = Drain
S = Source

Features

- Silicon chip on Direct-Copper-Bond substrate
 - High power dissipation
 - Isolated mounting surface
 - 2500V electrical isolation
- Low drain to tab capacitance (<30pF)
- Low $R_{DS(on)}$ HDMOS™ process
- Rugged polysilicon gate cell structure
- Unclamped Inductive Switching (UIS) rated
- Fast intrinsic Rectifier

Applications

- DC-DC converters
- Battery chargers
- Switched-mode and resonant-mode power supplies
- DC choppers
- AC motor control

Advantages

- Easy assembly
- Space savings
- High power density

Symbol	Test Conditions	Characteristic Values ($T_J = 25^\circ\text{C}$, unless otherwise specified)		
		min.	typ.	max.
V_{DSS}	$V_{GS} = 0 \text{ V}$, $I_D = 3 \text{ mA}$	900		V
$V_{GH(th)}$	$V_{DS} = V_{GS}$, $I_D = 8 \text{ mA}$	2.5		V
I_{GSS}	$V_{GS} = \pm 20 \text{ V}_{DC}$, $V_{DS} = 0$			± 200 nA
I_{DSS}	$V_{DS} = V_{DSS}$, $T_J = 25^\circ\text{C}$ $V_{GS} = 0 \text{ V}$, $T_J = 125^\circ\text{C}$			100 μA 2 mA
$R_{DS(on)}$	$V_{GS} = 10 \text{ V}$, $I_D = I_T$ Notes 2, 3			220 m Ω

Symbol	Test Conditions	Characteristic Values ($T_J = 25^\circ\text{C}$, unless otherwise specified)		
		min.	typ.	max.
g_{fs}	$V_{DS} = 15\text{ V}; I_D = I_T$, Note 2	30	45	S
C_{iss}	$V_{GS} = 0\text{ V}, V_{DS} = 25\text{ V}, f = 1\text{ MHz}$		13400	pF
C_{oss}			1230	pF
C_{rss}			320	pF
$t_{d(on)}$	$V_{GS} = 10\text{ V}, V_{DS} = 0.5 \cdot V_{DSS}, I_D = I_T$ $R_G = 1\ \Omega$ (External),		45	ns
t_r			68	ns
$t_{d(off)}$			125	ns
t_f			30	ns
$Q_{g(on)}$	$V_{GS} = 10\text{ V}, V_{DS} = 0.5 \cdot V_{DSS}, I_D = I_T$		375	nC
Q_{gs}			75	nC
Q_{gd}			190	nC
R_{thJC}			0.22	K/W
R_{thCK}		0.07		K/W

ISOPLUS 264 OUTLINE

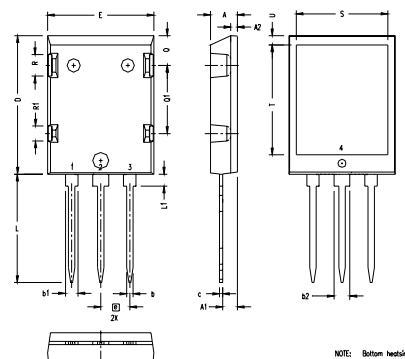

SYM	INCHES		MILLIMETERS	
	MIN	MAX	MIN	MAX
A	.190	.205	4.83	5.21
A1	.102	.118	2.59	3.00
A2	.046	.055	1.17	1.40
b	.045	.055	1.14	1.40
b1	.087	.102	2.21	2.59
b2	.111	.126	2.82	3.20
c	.020	.029	0.51	0.74
D	1.020	1.040	25.91	26.42
E	.770	.799	19.56	20.29
e	.215 BSC		5.46 BSC	
L	.780	.820	19.81	20.83
L1	.080	.102	2.03	2.59
Q	.210	.235	5.33	5.97
Q1	.490	.513	12.45	13.03
R	.150	.180	3.81	4.57
R1	.100	.130	2.54	3.30
S	.668	.690	16.97	17.53
T	.801	.821	20.34	20.85
U	.065	.080	1.65	2.03

NOTE: Bottom heatsink meets 2500Vrms isolation to the other pins.

Symbol	Test Conditions	Characteristic Values ($T_J = 25^\circ\text{C}$, unless otherwise specified)		
		min.	typ.	max.
I_s	$V_{GS} = 0\text{ V}$			39 A
I_{SM}	Repetitive; Note 1			154 A
V_{SD}	$I_F = I_s, V_{GS} = 0\text{ V}$, Note 2			1.3 V
t_{rr}	$I_F = 25\text{ A}, -di/dt = 100\text{ A}/\mu\text{s}, V_R = 100\text{ V}$			250 ns
Q_{RM}			2	μC
I_{RM}			9	A

- Notes:
1. Pulse width limited by T_{JM} .
 2. Pulse test, $t \leq 300\text{ ms}$, duty cycle $d \leq 2\%$.
 3. I_T Test current: $I_T = 19.5\text{ A}$

Please see IXFN39N90 data sheet for characteristic curves.

IXYS reserves the right to change limits, test conditions, and dimensions.