

OA254LFG XC Series

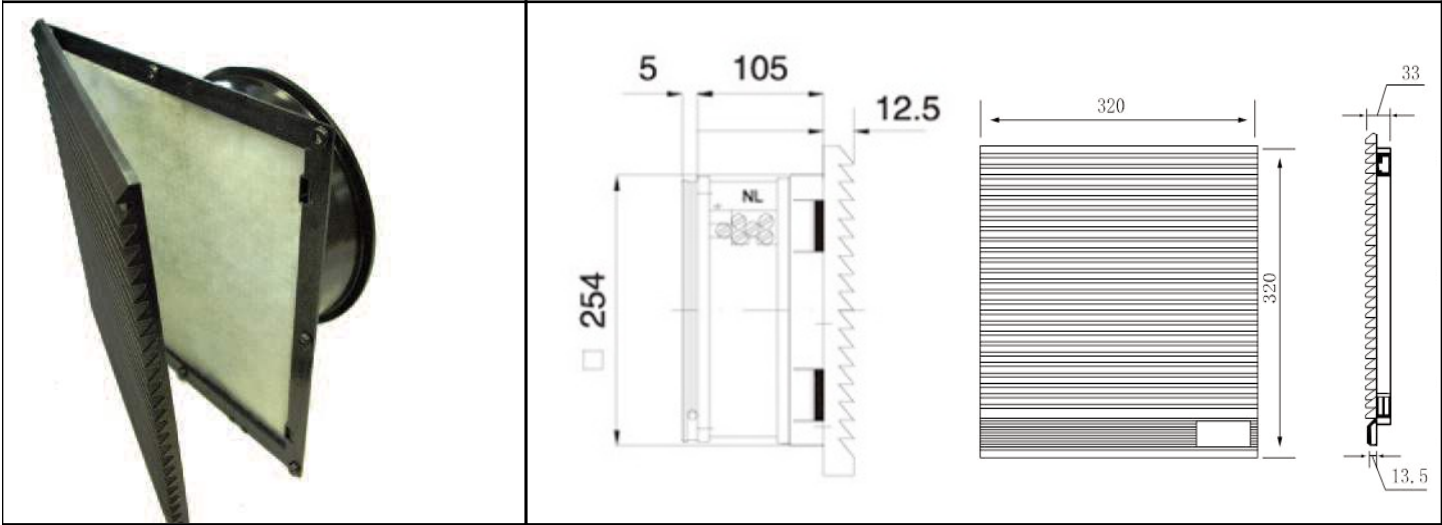

Louvered Filter Fan Kit with Fan Installed



Frame	Diecast Aluminum	Operating Temperature Ball Bearing -40C ~ +70C Life Expectancy Ball Bearing 60,000 hours (L10 at 40C) Environmental: Class B Insulation Rated IP54 Guard Guard Frame: ABS Resin UL94V-0 with UV protection Color: Black (standard) or Gray Filter Mesh: Nylon fiber Synthetic Resin m0
Impeller	PBT, UL94V-O plastic	
Connection	2x Lead Wires or Terminals	
Motor	Capacitor drive, impedance protected	
Bearing System	Dual ball	
Insulation Resistance	>100M ohm between lead-wire and frame (500VDC)	
Dielectric Strength	1 min at 1500 VAC, 50/60Hz	

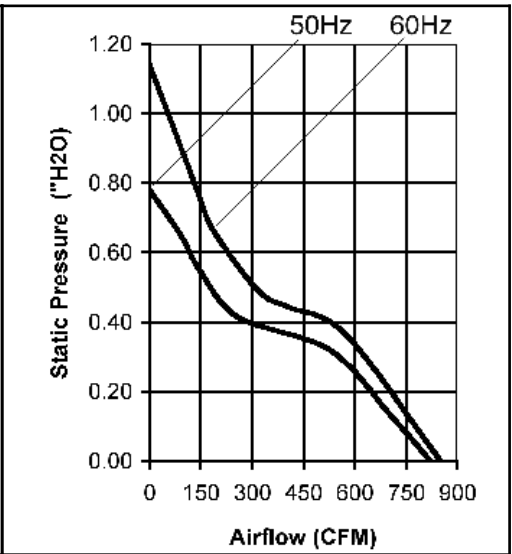

Model Number	OA254LFG111TXC	OA254LFG221TXC
Nominal Voltage	115 VAC	230 VAC
Voltage Range	80 ~ 130	160 ~ 260
Rated Power	75	75
Rated Speed (RPM)	2700	2700
Airflow (CFM)	850	850
Noise Level (dB)	69	69
Max. Static Pressure	0.78 "H2O	0.78" H2O

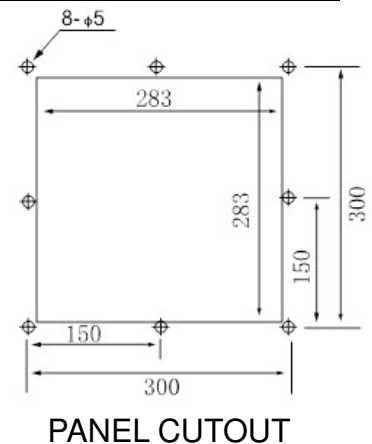

* Note: Airflow data is for the fan without the louvered filter attached. Calculations indicate that up to a 40% reduction (~ 510 CFM) in fan airflow is possible with LFG unit installed.