

REVISION		
REV	DESCRIPTION	DATE
C	REVISED PER ECO-12-018952	26OCT2012

If this document is printed it becomes uncontrolled. Check for the latest revision

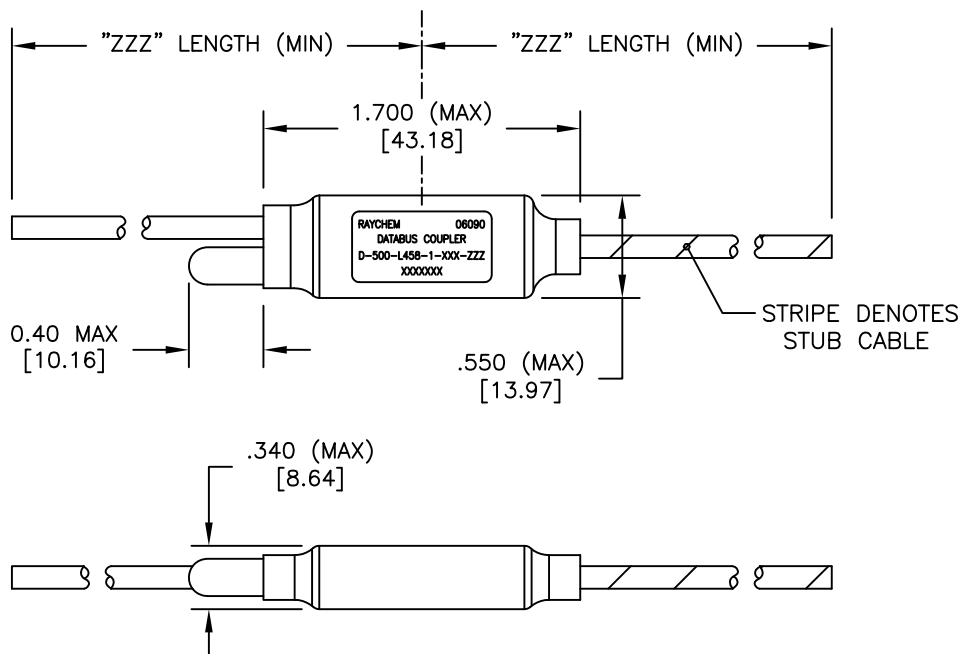

COMPONENT NUMBER

D-500-L458-1-XXX-ZZZ

8: REVERSE WITH INTERNAL TERMINATOR

SCHEMATIC

CABLE LENGTH (INCHES)

NUMBER OF STUBS

CABLE

- 612: 10612 (OPTIMIZED SINGLE SHIELD)
- 613: 10613 (OPTIMIZED DOUBLE SHIELD)
- 614: 10614 (EMP HARDENED)
- EP3: EPD30653Q (BUS), EPD31346A-6L9-US (STUB) (OPTIMIZED DOUBLE SHIELD)
- H06: 7724H0664 (FLAT SHIELD WIRE, UNFILLED)
- 6D0: 7726D0664 26 AWG OPTIMIZED SINGLE SHIELD
- 6D3: 7726D3664 26 AWG OPTIMIZED DOUBLE SHIELD
- C86: CABLE 7724C8664 SILVER PLATED EMP HARDENED

© 2012 Tyco Electronics Corporation. All Rights Reserved.

Raychem Databus
CUSTOMER DRAWING

UNLESS OTHERWISE SPECIFIED DIMENSIONS ARE INCHES. METRIC DIMENSIONS ARE IN BRACKETS. DECIMAL TOLERANCES .XXX ± 0.005 [0.13 mm] .XX ± 0.010 [0.25 mm] .X ± 0.020 [0.50 mm] ANGLE TOLERANCE .X ± 0.5 DEG. WEIGHT WITHOUT CABLE (MAX) LBS. 0.0161 [7.30 gm]	DRAWN T RATZLAFF	DATE 18APR2003		
	MATERIAL FINISH			TITLE DATABUS MICROCOUPLER, SINGLE STUB, REVERSE, WITH INTERNAL TERMINATOR, LIGHTWEIGHT
CAD FILE D-500-L458-1-XXX-ZZZ.a	THIRD ANGLE PROJECTION 	SIZE A	CODE IDENT. NO. 06090	DWG. NO. D-500-L458-1-XXX-ZZZ
	DO NOT SCALE THIS DRAWING		SHEET 1 OF 2	

If this document is printed it becomes uncontrolled. Check for the latest revision

1. MATERIAL AND FINISHES:
 - 1.1 INTERNAL COMPONENTS:
 - TRANSFORMER TO MIL-PRF-21038 AND MIL-STD-1553B
 - ISOLATION RESISTORS TO MIL-PRF-39007/9, 57.6 OHMS
 - TERMINATION RESISTOR TO MIL-PRF-39007/9, 76.8 OHMS
 - 1.2 SHIELDED CASE: ALUMINUM PER ASTM B 618 OR ASTM B211
 - 1.3 SEALED COVER: MODIFIED CROSS-LINKED, FLAME RETARDANT, BLACK, FLUOROPOLYMER TO RAYCHEM SPECIFICATION RT-370.
 - 1.4 CABLE TO RAYCHEM SPECIFICATION 1200.

2. APPLICATION:
 - 2.1 THIS COUPLER IS DESIGNED TO BE INSTALLED INTO A DIGITAL MULTIPLEX ASSEMBLY MEETING THE REQUIREMENTS OF MIL-STD-1553B.
 - 2.2 CABLE BEND RADIUS PER SAE-AS50881 STATIC BEND: 5 x CABLE O.D. MIN.
DYNAMIC BEND: 10 x CABLE O.D. MIN.

3. TEMPERATURE:
 - 3.1 OPERATING TEMPERATURE: -65°C TO +150°C

4. PERFORMANCE SPECIFICATIONS:
 - 4.1 COUPLER MEETS THE PERFORMANCE REQUIREMENTS OF MIL-STD-1553B AND USAF DRAWING 8912026.

5. WEIGHT:
 - 5.1 WEIGHT WITHOUT CABLE: 7.3 GRAMS (MAXIMUM).

6. ORDERING INFORMATION:
 - 6.1 ORDER PER COMPONENT NUMBER (SEE SHEET 1) AND DESIRED "ZZZ" CABLE LENGTH.
 - 6.2 SPECIFY CERTIFICATION OF CONFORMANCE REQUIREMENTS AS SEPARATE LINE ITEM.
 - 6.3 SPLICE KITS TO BE ORDERED SEPARATELY. PRODUCT NUMBER: D-150-0708-5.

SINGLE STUB COUPLER SCHEMATIC

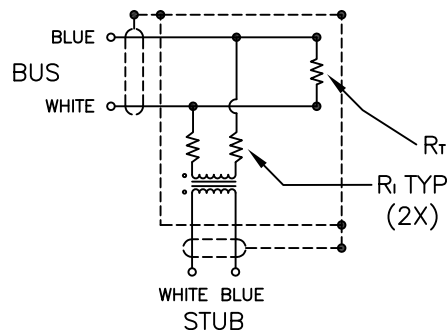

Raychem Databus
CUSTOMER DRAWING

SIZE	CODE IDENT. NO.	DWG. NO.	REV
A	06090	D-500-L458-1-XXX-ZZZ	C
DO NOT SCALE THIS DRAWING			SHEET 2 OF 2