

CIRCUIT SIZE	DIM. "A"	DIM. "B"	DIM. "C"	DIM. "D"	DIM. "E"
2	.520 (13.20)	—	.425 (10.80)	.370 (9.40)	.21 (5.4)
4	.685 (17.40)	.17 (4.2)	.590 (15.00)	.535 (13.60)	.38 (9.6)
6	.850 (21.60)	.33 (8.4)	.756 (19.20)	.701 (17.80)	.54 (13.8)
8	1.016 (25.80)	.50 (12.6)	.921 (23.40)	.866 (22.00)	.71 (18.0)
10	1.181 (30.00)	.66 (16.8)	1.087 (27.60)	1.031 (26.20)	.87 (22.2)
12	1.346 (34.20)	.83 (21.0)	1.252 (31.80)	1.197 (30.40)	1.04 (26.4)
14	1.512 (38.40)	.99 (25.2)	1.417 (36.00)	1.362 (34.60)	1.20 (30.6)
16	1.677 (42.60)	1.16 (29.4)	1.583 (40.20)	1.528 (38.80)	1.37 (34.8)
18	1.843 (46.80)	1.32 (33.6)	1.748 (44.40)	1.693 (43.00)	1.54 (39.0)
20	2.008 (51.00)	1.49 (37.8)	1.913 (48.60)	1.858 (47.20)	1.70 (43.2)
22	2.173 (55.20)	1.65 (42.0)	2.079 (52.80)	2.024 (51.40)	1.87 (47.4)
24	2.339 (59.40)	1.82 (46.2)	2.244 (57.00)	2.189 (55.60)	2.03 (51.6)

LEGEND:
 A - 42440 - *** *
 BASE NUMBER ——— PLATING (SEE NOTE 2.)
 CIRCUIT SIZE (02-24) ——— HOUSING MAT'L. & OPTIONS (SEE NOTE 1.)

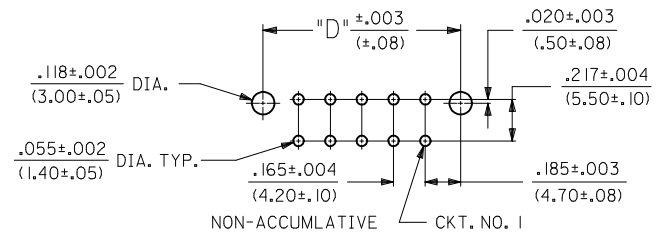

RECOMMENDED HOLE LAYOUT FOR .070/(1.78) MAX. THICK P.C. BOARD (SCALE: 2X)

---	22, ---23	42474-***21, 5556-GS*P	94V-0	BRASS	GOLD
---	12, ---13	42474-***11, 5556-GS*P	94V-2	BRASS	TIN
---	21	42474-***21, 5556-S*P	94V-0	BRASS	TIN
---	11	42474-***11, 5556-S*P	94V-2	BRASS	TIN
---	22, ---23,	A-42385-***B2, ---B4	94V-0	BRASS	GOLD
---	12, ---13,	A-42385-***A2, ---A4	94V-2	BRASS	GOLD
---	21	A-42385-***B1	94V-0	BRASS	TIN
---	11	A-42385-***A1	94V-2	BRASS	TIN
VERT. HEADER A-42440		MATING CONNECTOR	HSG. MAT'L. TERM. MAT'L., PLATING MATING CONNECTOR FEATURES		

ADD 0.40 TOL EC NO: UCP2013-0706 DRAWINGUYEN 2012/08/20 CHKD:JBELL 2012/08/20 APPR:FSMITH 2012/09/05	QUALITY SYMBOLS ▽=0 ▽=0 ▽=0	GENERAL TOLERANCES (UNLESS SPECIFIED)		DIMENSION STYLE IN/MM		SCALE 4:1	DESIGN UNITS METRIC	THIRD ANGLE PROJECTION
		mm INCH		DRAWN BY DATE GEP 1989/04/06		TITLE MINI-FIT B.M.I. VERTICAL HEADER ASSY		
Q5	REV	4 PLACES ± --- ± ---		CHECKED BY DATE RJF 1989/04/06		APPROVED BY DATE FSMITH 2011/02/11		
		3 PLACES ± --- ± .010		APPROVED BY DATE FSMITH 2011/02/11		MATERIAL NO. DOCUMENT NO. SEE CHART SDA-42440-****		
DRAFT WHERE APPLICABLE MUST REMAIN WITHIN DIMENSIONS		ANGULAR ± 5 °		SIZE C		SHEET NO. 1 OF 4		
THIS DRAWING CONTAINS INFORMATION THAT IS PROPRIETARY TO MOLEX INCORPORATED AND SHOULD NOT BE USED WITHOUT WRITTEN PERMISSION								

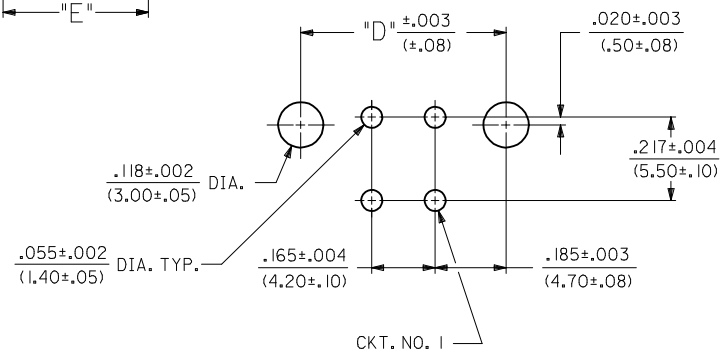
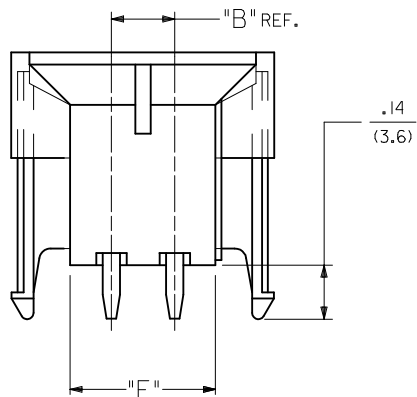
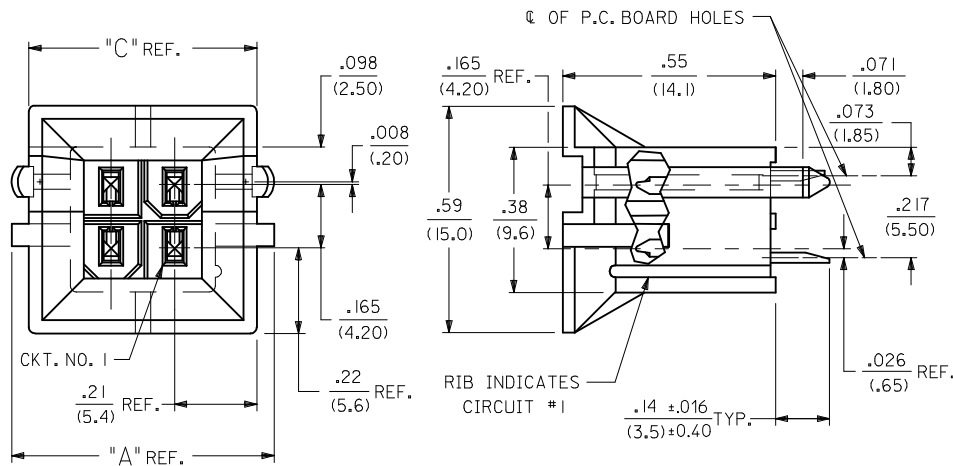

RECOMMENDED HOLE LAYOUT FOR .070/(1.78) MAX. THICK P.C. BOARD

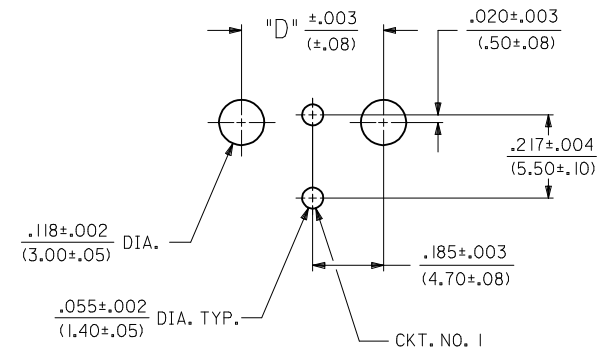
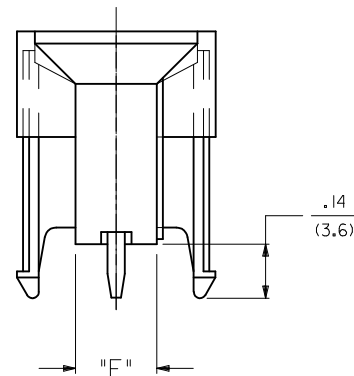
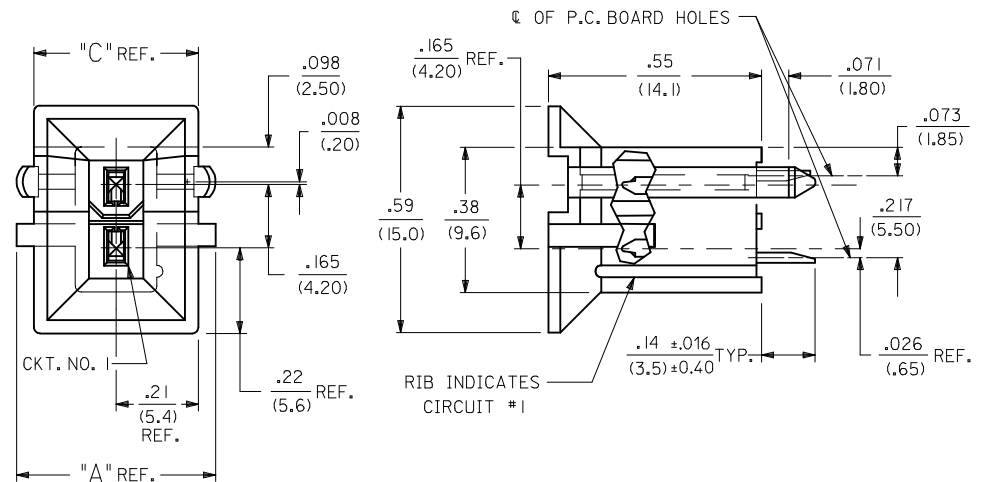

RECOMMENDED HOLE LAYOUT FOR .070/(1.78) MAX. THICK P.C. BOARD

SEE SHEET 1 EC NO: UCP2013-0706 DRAWN: NGUYEN CHKD: BELL APPR: FSMITH 2012/08/20 2012/08/20 2012/09/05	QUALITY SYMBOLS	GENERAL TOLERANCES (UNLESS SPECIFIED)	DIMENSION STYLE	SCALE	DESIGN UNITS	THIRD ANGLE PROJECTION
	▽=0	mm INCH	IN/MM	1:1	METRIC	
	▽=0	4 PLACES ± --- ± ---	DRAWN BY DATE	TITLE		
	▽=0	3 PLACES ± --- ± .010	CHECKED BY DATE	MINI-FIT B.M.I. VERTICAL HEADER ASSY		
	▽=0	2 PLACES ± 0.25 ± .015	RJF DATE	MOLEX INCORPORATED		
	1 PLACE ± 0.38 ± ---	APPROVED BY DATE	MATERIAL NO. DOCUMENT NO.			
		ANGULAR ± 5 °	SEE CHART			SHEET NO.
		DRAFT WHERE APPLICABLE MUST REMAIN WITHIN DIMENSIONS	THIS DRAWING CONTAINS INFORMATION THAT IS PROPRIETARY TO MOLEX INCORPORATED AND SHOULD NOT BE USED WITHOUT WRITTEN PERMISSION			2 OF 4

NOTES:

- 1) MATERIAL:
HOUSING MATERIAL:
1 = NYLON 6/6, UNFILLED UL 94V-2, COLOR: NATURAL
2 = NYLON 6/6, UNFILLED UL 94V-0, COLOR: NATURAL
TERMINALS: BRASS
- 2) TERMINAL PLATING:
S = .000100/(0.00254) MIN. BRIGHT TIN OVER .000050/(0.00127) MIN. NICKEL
GS = .000030/(0.00076) MIN. SELECT GOLD AND .000100/(0.00254) MIN.
SELECT MATTE TIN OVER .000050/(.00127) MIN. NICKEL OVERALL
GS3 = .000050/(0.00127) MIN. SELECT GOLD AND .000100/(0.00254) MIN.
SELECT MATTE TIN OVER .000050/(.00127) MIN. NICKEL OVERALL
- 3) PRODUCT SPECIFICATION: PS-5556-002
- 4) PACKAGING: SEE CHARTS
- 5) 6-24 CIRCUIT PARTS MATE WITH MINI-FIT JR. RECEPTACLES 5557, 42474, 44516 AND HEADERS 42385; 2 AND 4 CIRCUIT PARTS MATE WITH 42385,44516 AND 42474 ONLY.
- 6) PART ALLOWS FOR UP TO .100/(2.54) MISALIGNMENT WITH MATING RECEPTACLE IN ANY DIRECTION. SEE MATING CONNECTOR DRAWINGS FOR SPECIFIC ALLOWANCES.
- 7) CONNECTOR IS NOT DESIGNED FOR CURRENT SHARING.
- 8) CONNECTOR ASSEMBLIES ARE NOT BE MATED OR UNMATED WHILE CIRCUITS ARE LIVE.
- 9) RIB LOCATION IS DETERMINED BY MOLD DESIGN FOR MANUFACTURING EASE AND THE LOCATION DOES NOT AFFECT PART FUNCTION OR PERFORMANCE. LOCATION OF RIBS MAY VARY ON PARTS WITHIN MAUFACTURING LOT OR SHIPMENT. THIS DRAWING SHOWS TYPICAL RIB LOCATIONS.
- 10) PART CONFORMS TO CLASS "B" REQUIREMENTS OF COSMETIC SPECIFICATION PS-45499-002.
- 11) 12 CIRCUIT PARTS HAVE A SLOT BETWEEN CIRCUITS 7 AND 8.

SEE SHEET 1 EC NO: UCP2013-0706 DRAWING: NGUYEN 2012/08/20 CHKD: BELLE 2012/08/20 APPR: FSMITH 2012/09/05	QUALITY SYMBOLS	GENERAL TOLERANCES (UNLESS SPECIFIED)		DIMENSION STYLE IN/MM		SCALE 1:1	DESIGN UNITS METRIC	THIRD ANGLE PROJECTION	
		mm	INCH	DRAWN BY GEP	DATE 1989/04/06	TITLE MINI-FIT B.M.I. VERTICAL HEADER ASSY			
		4 PLACES ± ---	± ---	CHECKED BY RJF	DATE 1989/04/06				
		3 PLACES ± ---	± .010	APPROVED BY FSMITH	DATE 2011/02/11				
			2 PLACES ± 0.25	± .015	ANGULAR ± 5 °		MOLEX INCORPORATED		MATERIAL NO. SEE CHART
		1 PLACE ± 0.38	± ---	DRAFT WHERE APPLICABLE MUST REMAIN WITHIN DIMENSIONS		DOCUMENT NO. SDA-42440-****		SHEET NO. 3 OF 4	
Q5	REV	SIZE C THIS DRAWING CONTAINS INFORMATION THAT IS PROPRIETARY TO MOLEX INCORPORATED AND SHOULD NOT BE USED WITHOUT WRITTEN PERMISSION							

	13		12		11		10		9		8		7		6		5		4		3		2		1
J	PLATING:	TIN (SEE NOTE 2 OPTION 'S')				PLATING:	TIN (SEE NOTE 2 OPTION 'S')				PLATING:	30 M.I. SELECT GOLD (SEE NOTE 2 OPTION 'GS')				PLATING:	30 M.I. SELECT GOLD (SEE NOTE 2 OPTION 'GS')								
	DRAINS:	WITHOUT DRAIN HOLES				DRAINS:	WITHOUT DRAIN HOLES				DRAINS:	WITHOUT DRAIN HOLES				DRAINS:	WITHOUT DRAIN HOLES								
	PEGS:	WITH PEGS				PEGS:	WITH PEGS				PEGS:	WITH PEGS				PEGS:	WITH PEGS								
	MAT'L:	94V-2 [NATURAL]				MAT'L:	94V-0 [NATURAL]				MAT'L:	94V-2 [NATURAL]				MAT'L:	94V-0 [NATURAL]								
	PACKAGING:	TRAY PER PK-42440-001				PACKAGING:	TRAY PER PK-42440-001				PACKAGING:	TRAY PER PK-42440-001				PACKAGING:	TRAY PER PK-42440-001								
I	PART NO.	ENG NO.		CKTS	PART NO.	ENG NO.		CKTS	PART NO.	ENG NO.		CKTS	PART NO.	ENG NO.		CKTS									
	NO EDP	A-42440-0211	-	2	NO EDP	A-42440-0221	-	2	NO EDP	A-42440-0212	-	2	NO EDP	A-42440-0222	-	2									
	15-24-6041	A-42440-0411	-	4	15-24-6042	A-42440-0421	-	4	15-28-6041	A-42440-0412	-	4	15-28-6042	A-42440-0422	-	4									
	15-24-6061	A-42440-0611	-	6	15-24-6062	A-42440-0621	-	6	15-28-6061	A-42440-0612	-	6	15-28-6062	A-42440-0622	-	6									
	NO EDP	A-42440-0811	-	8	NO EDP	A-42440-0821	-	8	NO EDP	A-42440-0812	-	8	NO EDP	A-42440-0822	-	8									
	15-24-6101	A-42440-1011	-	10	15-24-6102	A-42440-1021	-	10	15-28-6101	A-42440-1012	-	10	15-28-6102	A-42440-1022	-	10									
	15-24-6121	A-42440-1211	-	12	15-24-6122	A-42440-1221	-	12	15-28-6121	A-42440-1212	-	12	15-28-6122	A-42440-1222	-	12									
	15-24-6141	A-42440-1411	-	14	15-24-6142	A-42440-1421	-	14	15-28-6141	A-42440-1412	-	14	15-28-6142	A-42440-1422	-	14									
	15-24-6161	A-42440-1611	-	16	15-24-6162	A-42440-1621	-	16	15-28-6161	A-42440-1612	-	16	NO EDP	A-42440-1622	-	16									
H	15-24-6181	A-42440-1811	-	18	15-24-6182	A-42440-1821	-	18	15-28-6181	A-42440-1812	-	18	15-28-6182	A-42440-1822	-	18									
	NO EDP	A-42440-2011	-	20	NO EDP	A-42440-2021	-	20	NO EDP	A-42440-2012	-	20	NO EDP	A-42440-2022	-	20									
	NO EDP	A-42440-2211	-	22	NO EDP	A-42440-2221	-	22	NO EDP	A-42440-2212	-	22	NO EDP	A-42440-2222	-	22									
	15-24-6241	A-42440-2411	-	24	15-24-6242	A-42440-2421	-	24	15-28-6241	A-42440-2412	-	24	15-28-6242	A-42440-2422	-	24									
		-	-			-	-			-	-			-	-										
		-	-			-	-			-	-			-	-										

G	PLATING:	50 M.I. SELECT GOLD (SEE NOTE 2 OPTION 'GS3')				PLATING:	50 M.I. SELECT GOLD (SEE NOTE 2 OPTION 'GS3')				PLATING:					PLATING:				
	DRAINS:	WITHOUT DRAIN HOLES				DRAINS:	WITHOUT DRAIN HOLES				DRAINS:					DRAINS:				
	PEGS:	WITH PEGS				PEGS:	WITH PEGS				PEGS:					PEGS:				
	MAT'L:	94V-2 [NATURAL]				MAT'L:	94V-0 [NATURAL]				MAT'L:					MAT'L:				
	PACKAGING:	TRAY PER PK-42440-001				PACKAGING:	TRAY PER PK-42440-001				PACKAGING:					PACKAGING:				
F	PART NO.	ENG NO.		CKTS	PART NO.	ENG NO.		CKTS	PART NO.	ENG NO.		CKTS	PART NO.	ENG NO.		CKTS				
	NO EDP	A-42440-0213	-	2	NO EDP	A-42440-0223	-	2	NO EDP	-	-	2	NO EDP	-	-	2				
	NO EDP	A-42440-0413	-	4	NO EDP	A-42440-0423	-	4	NO EDP	-	-	4	NO EDP	-	-	4				
	NO EDP	A-42440-0613	-	6	NO EDP	A-42440-0623	-	6	NO EDP	-	-	6	NO EDP	-	-	6				
	NO EDP	A-42440-0813	-	8	NO EDP	A-42440-0823	-	8	NO EDP	-	-	8	NO EDP	-	-	8				
	NO EDP	A-42440-1013	-	10	NO EDP	A-42440-1023	-	10	NO EDP	-	-	10	NO EDP	-	-	10				
	NO EDP	A-42440-1213	-	12	NO EDP	A-42440-1223	-	12	NO EDP	-	-	12	NO EDP	-	-	12				
E	NO EDP	A-42440-1413	-	14	NO EDP	A-42440-1423	-	14	NO EDP	-	-	14	NO EDP	-	-	14				
	NO EDP	A-42440-1613	-	16	NO EDP	A-42440-1623	-	16	NO EDP	-	-	16	NO EDP	-	-	16				
	NO EDP	A-42440-1813	-	18	NO EDP	A-42440-1823	-	18	NO EDP	-	-	18	NO EDP	-	-	18				
	NO EDP	A-42440-2013	-	20	NO EDP	A-42440-2023	-	20	NO EDP	-	-	20	NO EDP	-	-	20				
	NO EDP	A-42440-2213	-	22	NO EDP	A-42440-2223	-	22	NO EDP	-	-	22	NO EDP	-	-	22				
	NO EDP	A-42440-2413	-	24	NO EDP	A-42440-2423	-	24	NO EDP	-	-	24	NO EDP	-	-	24				
		-	-			-	-			-	-			-	-					
		-	-			-	-			-	-			-	-					

SEE SHEET 1 EC NO: UCP2013-0706 DRAWING NO: 2012/08/20 CHKD: JBELL APPR: FSMITH	DESCRIPTION QUALITY SYMBOLS ▽=0 ▽=0 ▽=0	GENERAL TOLERANCES (UNLESS SPECIFIED)		DIMENSION STYLE IN/MM		SCALE 1:1	DESIGN UNITS METRIC	THIRD ANGLE PROJECTION			
		4 PLACES ± --- ± ---	3 PLACES ± --- ± .010	2 PLACES ± 0.25 ± .015	1 PLACE ± 0.38 ± ---	DRAWN BY GEP	DATE 1989/04/06	TITLE MINI-FIT B.M.I. VERTICAL HEADER ASSY			
		ANGULAR ± 5 °				CHECKED BY RJF	DATE 1989/04/06				
		DRAFT WHERE APPLICABLE MUST REMAIN WITHIN DIMENSIONS				MATERIAL NO. SEE CHART		DOCUMENT NO. SDA-42440-****		SHEET NO. 4 OF 4	
THIS DRAWING CONTAINS INFORMATION THAT IS PROPRIETARY TO MOLEX INCORPORATED AND SHOULD NOT BE USED WITHOUT WRITTEN PERMISSION											

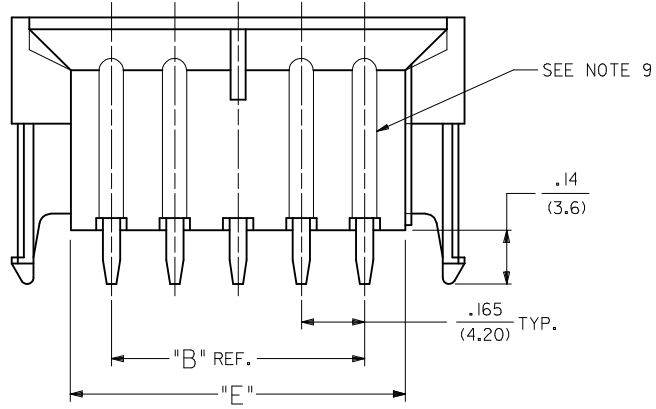
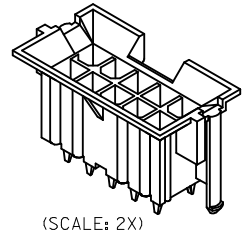
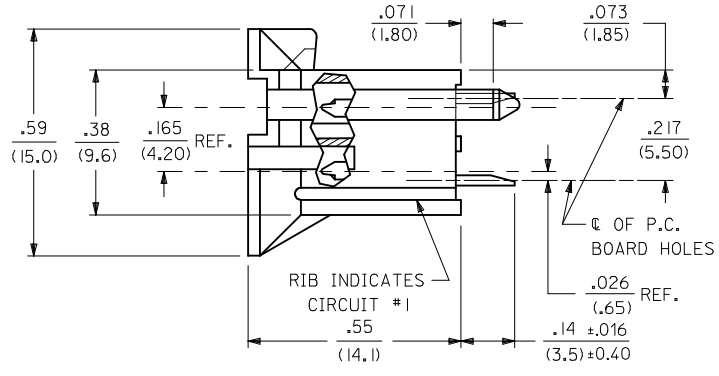
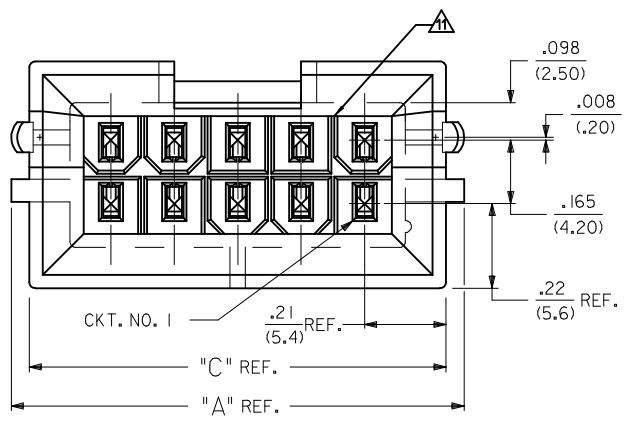

CIRCUIT SIZE	DIM. "A"	DIM. "B"	DIM. "C"	DIM. "D"	DIM. "E"
2	.520 (13.20)	—	.425 (10.80)	.370 (9.40)	.21 (5.4)
4	.685 (17.40)	.17 (4.2)	.590 (15.00)	.535 (13.60)	.38 (9.6)
6	.850 (21.60)	.33 (8.4)	.756 (19.20)	.701 (17.80)	.54 (13.8)
8	1.016 (25.80)	.50 (12.6)	.921 (23.40)	.866 (22.00)	.71 (18.0)
10	1.181 (30.00)	.66 (16.8)	1.087 (27.60)	1.031 (26.20)	.87 (22.2)
12	1.346 (34.20)	.83 (21.0)	1.252 (31.80)	1.197 (30.40)	1.04 (26.4)
14	1.512 (38.40)	.99 (25.2)	1.417 (36.00)	1.362 (34.60)	1.20 (30.6)
16	1.677 (42.60)	1.16 (29.4)	1.583 (40.20)	1.528 (38.80)	1.37 (34.8)
18	1.843 (46.80)	1.32 (33.6)	1.748 (44.40)	1.693 (43.00)	1.54 (39.0)
20	2.008 (51.00)	1.49 (37.8)	1.913 (48.60)	1.858 (47.20)	1.70 (43.2)
22	2.173 (55.20)	1.65 (42.0)	2.079 (52.80)	2.024 (51.40)	1.87 (47.4)
24	2.339 (59.40)	1.82 (46.2)	2.244 (57.00)	2.189 (55.60)	2.03 (51.6)

LEGEND:
 A - 42440 - *** *
 BASE NUMBER ——— PLATING (SEE NOTE 2.)
 CIRCUIT SIZE (02-24) ——— HOUSING MAT'L. & OPTIONS (SEE NOTE 1.)

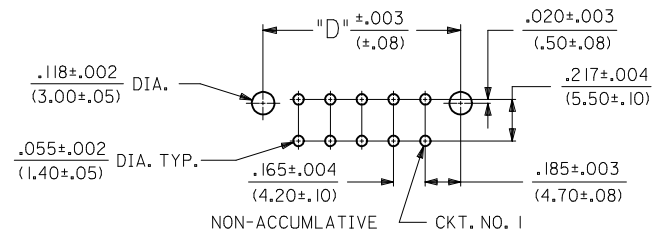

---	22, ---23	42474-***21, 5556-GS*P	94V-0	BRASS	GOLD
---	12, ---13	42474-***11, 5556-GS*P	94V-2	BRASS	TIN
---	21	42474-***21, 5556-S*P	94V-0	BRASS	TIN
---	11	42474-***11, 5556-S*P	94V-2	BRASS	TIN
---	22, ---23,	A-42385-***B2, ---B4	94V-0	BRASS	GOLD
---	12, ---13,	A-42385-***A2, ---A4	94V-2	BRASS	TIN
---	21	A-42385-***B1	94V-0	BRASS	TIN
---	11	A-42385-***A1	94V-2	BRASS	TIN
VERT. HEADER A-42440		MATING CONNECTOR	HSG. MAT'L. TERM. MAT'L. PLATING MATING CONNECTOR FEATURES		

ADD 0.40 TOL
 EC NO: UCP2013-0706
 DRAWING: NGUYEN 2012/08/20
 CHKD: JEBEL 2012/08/20
 APPR: FSMITH 2012/09/05

QUALITY SYMBOLS
 ▽=0
 ▽=0
 ▽=0

GENERAL TOLERANCES (UNLESS SPECIFIED)

	DIMENSION STYLE	
	mm	INCH
4 PLACES ± ---	± ---	± ---
3 PLACES ± ---	± .010	± .010
2 PLACES ± 0.25	± .015	± .015
1 PLACE ± 0.38	± ---	± ---
ANGULAR ± 5 °		

DRAFT WHERE APPLICABLE MUST REMAIN WITHIN DIMENSIONS

SCALE 4:1
DESIGN UNITS METRIC
THIRD ANGLE PROJECTION

MINI-FIT B.M.I. VERTICAL HEADER ASSY

MOLEX INCORPORATED

SEE CHART
 MATERIAL NO. SDA-42440-****
 DOCUMENT NO. 1 OF 4

THIS DRAWING CONTAINS INFORMATION THAT IS PROPRIETARY TO MOLEX INCORPORATED AND SHOULD NOT BE USED WITHOUT WRITTEN PERMISSION

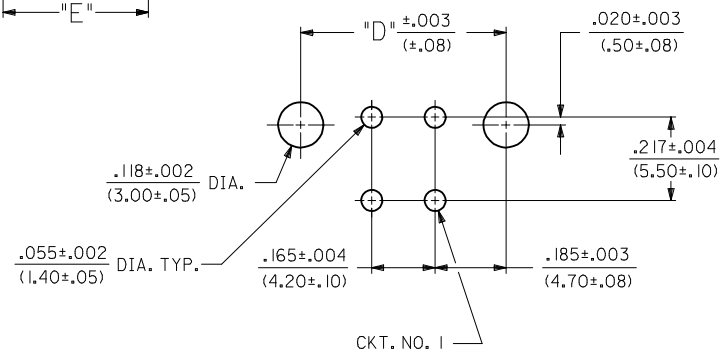
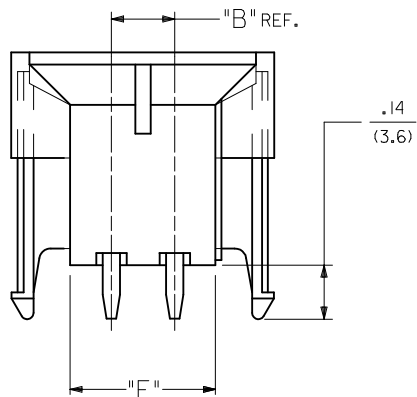
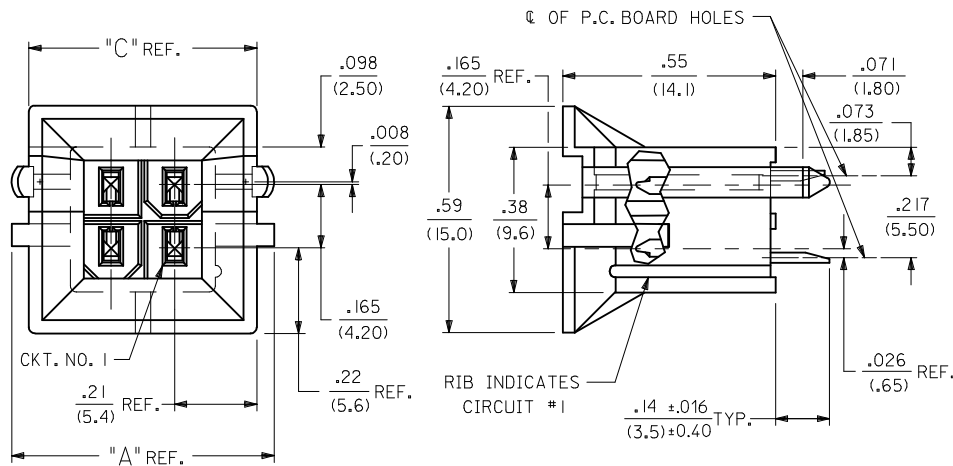

RECOMMENDED HOLE LAYOUT FOR .070/(1.78) MAX. THICK P.C. BOARD

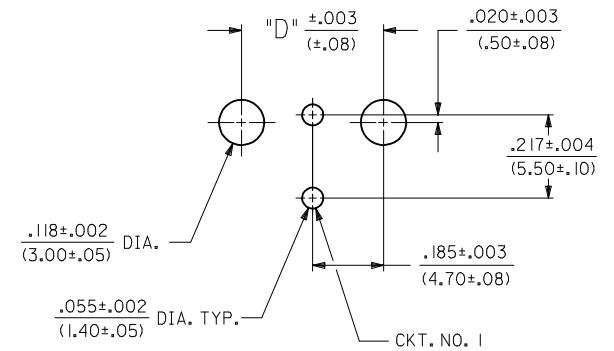
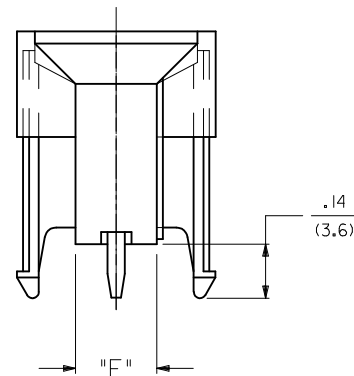
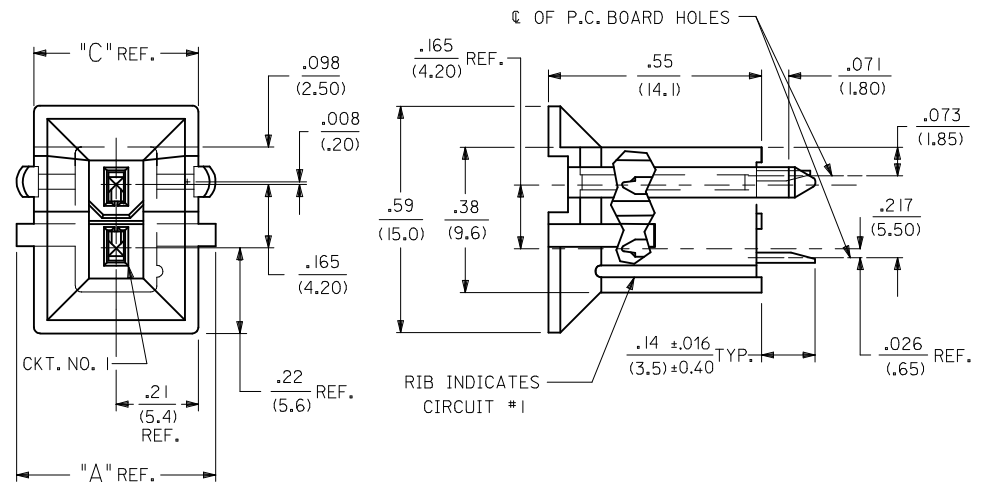

RECOMMENDED HOLE LAYOUT FOR .070/(1.78) MAX. THICK P.C. BOARD

SEE SHEET 1 EC NO: UCP2013-0706 DRAWN: NGUYEN CHKD: J.BELL APPR: F.SMITH 2012/08/20 2012/08/20 2012/09/05	QUALITY SYMBOLS	GENERAL TOLERANCES (UNLESS SPECIFIED)	DIMENSION STYLE	SCALE	DESIGN UNITS	THIRD ANGLE PROJECTION
	▽=0	mm INCH	IN/MM	1:1	METRIC	
	▽=0	4 PLACES ± --- ± ---	DRAWN BY DATE	TITLE		
	▽=0	3 PLACES ± --- ± .010	CHECKED BY DATE	MINI-FIT B.M.I. VERTICAL HEADER ASSY		
	▽=0	2 PLACES ± 0.25 ± .015	RJF 1989/04/06	MOLEX INCORPORATED		
	1 PLACE ± 0.38 ± ---	APPROVED BY DATE	F.SMITH 2011/02/11	MATERIAL NO. DOCUMENT NO. SHEET NO.		
		ANGULAR ± 5 °	SEE CHART	SDA-42440-**** 2 OF 4		
		DRAFT WHERE APPLICABLE MUST REMAIN WITHIN DIMENSIONS	THIS DRAWING CONTAINS INFORMATION THAT IS PROPRIETARY TO MOLEX INCORPORATED AND SHOULD NOT BE USED WITHOUT WRITTEN PERMISSION			

NOTES:

- 1) MATERIAL:
HOUSING MATERIAL:
1 = NYLON 6/6, UNFILLED UL 94V-2, COLOR: NATURAL
2 = NYLON 6/6, UNFILLED UL 94V-0, COLOR: NATURAL
TERMINALS: BRASS
- 2) TERMINAL PLATING:
S = .000100/(0.00254) MIN. BRIGHT TIN OVER .000050/(0.00127) MIN. NICKEL
GS = .000030/(0.00076) MIN. SELECT GOLD AND .000100/(0.00254) MIN.
SELECT MATTE TIN OVER .000050/(.00127) MIN. NICKEL OVERALL
GS3 = .000050/(0.00127) MIN. SELECT GOLD AND .000100/(0.00254) MIN.
SELECT MATTE TIN OVER .000050/(.00127) MIN. NICKEL OVERALL
- 3) PRODUCT SPECIFICATION: PS-5556-002
- 4) PACKAGING: SEE CHARTS
- 5) 6-24 CIRCUIT PARTS MATE WITH MINI-FIT JR. RECEPTACLES 5557, 42474, 44516 AND HEADERS 42385; 2 AND 4 CIRCUIT PARTS MATE WITH 42385,44516 AND 42474 ONLY.
- 6) PART ALLOWS FOR UP TO .100/(2.54) MISALIGNMENT WITH MATING RECEPTACLE IN ANY DIRECTION. SEE MATING CONNECTOR DRAWINGS FOR SPECIFIC ALLOWANCES.
- 7) CONNECTOR IS NOT DESIGNED FOR CURRENT SHARING.
- 8) CONNECTOR ASSEMBLIES ARE NOT BE MATED OR UNMATED WHILE CIRCUITS ARE LIVE.
- 9) RIB LOCATION IS DETERMINED BY MOLD DESIGN FOR MANUFACTURING EASE AND THE LOCATION DOES NOT AFFECT PART FUNCTION OR PERFORMANCE. LOCATION OF RIBS MAY VARY ON PARTS WITHIN MAUFACTURING LOT OR SHIPMENT. THIS DRAWING SHOWS TYPICAL RIB LOCATIONS.
- 10) PART CONFORMS TO CLASS "B" REQUIREMENTS OF COSMETIC SPECIFICATION PS-45499-002.
- 11) 12 CIRCUIT PARTS HAVE A SLOT BETWEEN CIRCUITS 7 AND 8.

SEE SHEET 1 EC NO: UCP2013-0706 DRAWN: NGUYEN 2012/08/20 CHKD: BELLE 2012/08/20 APPR: FSMITH 2012/09/05	QUALITY SYMBOLS	GENERAL TOLERANCES (UNLESS SPECIFIED)		DIMENSION STYLE IN/MM		SCALE 1:1	DESIGN UNITS METRIC	THIRD ANGLE PROJECTION	
	▽=0	mm	INCH	DRAWN BY	DATE	MINI-FIT B.M.I. VERTICAL HEADER ASSY			
	▽=0	4 PLACES ± --- ± ---	GEP	1989/04/06					
	▽=0	3 PLACES ± --- ± .010	CHECKED BY	DATE					
			2 PLACES ± 0.25 ± .015	RJF	1989/04/06	MOLEX INCORPORATED SDA-42440-****			
		1 PLACE ± 0.38 ± ---	APPROVED BY	DATE					
		ANGULAR ± 5 °	FSMITH	2011/02/11	MATERIAL NO.		DOCUMENT NO.		SHEET NO.
		DRAFT WHERE APPLICABLE MUST REMAIN WITHIN DIMENSIONS	SEE CHART		SDA-42440-****		3 OF 4		
			THIS DRAWING CONTAINS INFORMATION THAT IS PROPRIETARY TO MOLEX INCORPORATED AND SHOULD NOT BE USED WITHOUT WRITTEN PERMISSION						

13	12	11	10	9	8	7	6	5	4	3	2	1			
PLATING: TIN (SEE NOTE 2 OPTION 'S')				PLATING: TIN (SEE NOTE 2 OPTION 'S')				PLATING: 30 M.I. SELECT GOLD (SEE NOTE 2 OPTION 'GS')				PLATING: 30 M.I. SELECT GOLD (SEE NOTE 2 OPTION 'GS')			
DRAINS: WITHOUT DRAIN HOLES				DRAINS: WITHOUT DRAIN HOLES				DRAINS: WITHOUT DRAIN HOLES				DRAINS: WITHOUT DRAIN HOLES			
PEGS: WITH PEGS				PEGS: WITH PEGS				PEGS: WITH PEGS				PEGS: WITH PEGS			
MAT'L: 94V-2 [NATURAL]				MAT'L: 94V-0 [NATURAL]				MAT'L: 94V-2 [NATURAL]				MAT'L: 94V-0 [NATURAL]			
PACKAGING: TRAY PER PK-42440-001				PACKAGING: TRAY PER PK-42440-001				PACKAGING: TRAY PER PK-42440-001				PACKAGING: TRAY PER PK-42440-001			
PART NO.	ENG NO.		CKTS	PART NO.	ENG NO.		CKTS	PART NO.	ENG NO.		CKTS	PART NO.	ENG NO.		CKTS
NO EDP	A-42440-021I	-	2	NO EDP	A-42440-022I	-	2	NO EDP	A-42440-0212	-	2	NO EDP	A-42440-0222	-	2
15-24-6041	A-42440-041I	-	4	15-24-6042	A-42440-042I	-	4	15-28-6041	A-42440-0412	-	4	15-28-6042	A-42440-0422	-	4
15-24-6061	A-42440-061I	-	6	15-24-6062	A-42440-062I	-	6	15-28-6061	A-42440-0612	-	6	15-28-6062	A-42440-0622	-	6
NO EDP	A-42440-081I	-	8	NO EDP	A-42440-082I	-	8	NO EDP	A-42440-0812	-	8	NO EDP	A-42440-0822	-	8
15-24-6101	A-42440-101I	-	10	15-24-6102	A-42440-102I	-	10	15-28-6101	A-42440-1012	-	10	15-28-6102	A-42440-1022	-	10
15-24-6121	A-42440-121I	-	12	15-24-6122	A-42440-122I	-	12	15-28-6121	A-42440-1212	-	12	15-28-6122	A-42440-1222	-	12
15-24-6141	A-42440-141I	-	14	15-24-6142	A-42440-142I	-	14	15-28-6141	A-42440-1412	-	14	15-28-6142	A-42440-1422	-	14
15-24-6161	A-42440-161I	-	16	15-24-6162	A-42440-162I	-	16	15-28-6161	A-42440-1612	-	16	NO EDP	A-42440-1622	-	16
15-24-6181	A-42440-181I	-	18	15-24-6182	A-42440-182I	-	18	15-28-6181	A-42440-1812	-	18	15-28-6182	A-42440-1822	-	18
NO EDP	A-42440-201I	-	20	NO EDP	A-42440-202I	-	20	NO EDP	A-42440-2012	-	20	NO EDP	A-42440-2022	-	20
NO EDP	A-42440-221I	-	22	NO EDP	A-42440-222I	-	22	NO EDP	A-42440-2212	-	22	NO EDP	A-42440-2222	-	22
15-24-6241	A-42440-241I	-	24	15-24-6242	A-42440-242I	-	24	15-28-6241	A-42440-2412	-	24	15-28-6242	A-42440-2422	-	24
	-	-			-	-			-	-			-	-	
	-	-			-	-			-	-			-	-	

PLATING: 50 M.I. SELECT GOLD (SEE NOTE 2 OPTION 'GS3')				PLATING: 50 M.I. SELECT GOLD (SEE NOTE 2 OPTION 'GS3')				PLATING:				PLATING:			
DRAINS: WITHOUT DRAIN HOLES				DRAINS: WITHOUT DRAIN HOLES				DRAINS:				DRAINS:			
PEGS: WITH PEGS				PEGS: WITH PEGS				PEGS:				PEGS:			
MAT'L: 94V-2 [NATURAL]				MAT'L: 94V-0 [NATURAL]				MAT'L:				MAT'L:			
PACKAGING: TRAY PER PK-42440-001				PACKAGING: TRAY PER PK-42440-001				PACKAGING:				PACKAGING:			
PART NO.	ENG NO.		CKTS	PART NO.	ENG NO.		CKTS	PART NO.	ENG NO.		CKTS	PART NO.	ENG NO.		CKTS
NO EDP	A-42440-0213	-	2	NO EDP	A-42440-0223	-	2	NO EDP	-	-	2	NO EDP	-	-	2
NO EDP	A-42440-0413	-	4	NO EDP	A-42440-0423	-	4	NO EDP	-	-	4	NO EDP	-	-	4
NO EDP	A-42440-0613	-	6	NO EDP	A-42440-0623	-	6	NO EDP	-	-	6	NO EDP	-	-	6
NO EDP	A-42440-0813	-	8	NO EDP	A-42440-0823	-	8	NO EDP	-	-	8	NO EDP	-	-	8
NO EDP	A-42440-1013	-	10	NO EDP	A-42440-1023	-	10	NO EDP	-	-	10	NO EDP	-	-	10
NO EDP	A-42440-1213	-	12	NO EDP	A-42440-1223	-	12	NO EDP	-	-	12	NO EDP	-	-	12
NO EDP	A-42440-1413	-	14	NO EDP	A-42440-1423	-	14	NO EDP	-	-	14	NO EDP	-	-	14
NO EDP	A-42440-1613	-	16	NO EDP	A-42440-1623	-	16	NO EDP	-	-	16	NO EDP	-	-	16
NO EDP	A-42440-1813	-	18	NO EDP	A-42440-1823	-	18	NO EDP	-	-	18	NO EDP	-	-	18
NO EDP	A-42440-2013	-	20	NO EDP	A-42440-2023	-	20	NO EDP	-	-	20	NO EDP	-	-	20
NO EDP	A-42440-2213	-	22	NO EDP	A-42440-2223	-	22	NO EDP	-	-	22	NO EDP	-	-	22
NO EDP	A-42440-2413	-	24	NO EDP	A-42440-2423	-	24	NO EDP	-	-	24	NO EDP	-	-	24
	-	-			-	-			-	-			-	-	
	-	-			-	-			-	-			-	-	

SEE SHEET 1 EC NO: UCP2013-0706 DRAWING: NGUYEN 2012/08/20 CHKD: J.BELL 2012/08/20 APPR: F.SMITH	QUALITY SYMBOLS ∇=0 ∇=0 ∇=0	GENERAL TOLERANCES (UNLESS SPECIFIED)		DIMENSION STYLE IN/MM		SCALE 1:1	DESIGN UNITS METRIC	THIRD ANGLE PROJECTION			
		4 PLACES ± --- ± ---	3 PLACES ± --- ± .010	2 PLACES ± 0.25 ± .015	1 PLACE ± 0.38 ± ---	DRAWN BY GEP	DATE 1989/04/06	MINI-FIT B.M.I. VERTICAL HEADER ASSY			
		ANGULAR ± 5 °				CHECKED BY R.J.F.	DATE 1989/04/06				
		DRAFT WHERE APPLICABLE MUST REMAIN WITHIN DIMENSIONS				MATERIAL NO. SEE CHART		DOCUMENT NO. SDA-42440-****		SHEET NO. 4 OF 4	
THIS DRAWING CONTAINS INFORMATION THAT IS PROPRIETARY TO MOLEX INCORPORATED AND SHOULD NOT BE USED WITHOUT WRITTEN PERMISSION											