

# 30 V PMOS-NMOS Bridge Driver

## FAN3278/D

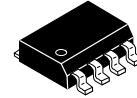

SOIC8  
CASE 751EB

### Description

The FAN3278 dual 1.5 A gate driver is optimized to drive a high-side P-channel MOSFET and a low-side N-channel MOSFET in motor control applications operating from a voltage rail up to 27 V. Internal circuitry limits the voltage applied to the gates of the external MOSFETs to 13 V maximum. The driver has TTL input thresholds and provides buffer and level translation from logic inputs. Internal circuitry prevents the output switching devices from operating if the  $V_{DD}$  supply voltage is below the IC operation level. Internal 100 k $\Omega$  resistors bias the non-inverting output LOW and the inverting output to  $V_{DD}$  to keep the external MOSFETs off during startup intervals when logic control signals may not be present.

The FAN3278 driver incorporates MOSFET devices for the final output stage, providing high current throughout the MOSFET turn-on / turn-off transition to minimize switching loss. The internal gate-drive regulators provide optimum gate-drive voltage when operating from a rail of 8 V to 27 V. The FAN3278 can be driven from a voltage rail of less than 8 V; however, its gate drive current is reduced.

The FAN3278 has two independent ENABLE pins that default to ON if not connected. If the ENABLE pin for non-inverting channel A is pulled LOW, OUTA is forced LOW. If the ENABLE pin for inverting channel B is pulled LOW, OUTB is forced HIGH. If an input is left unconnected, internal resistors bias the inputs such that the external MOSFETs are OFF.

### Features

- 8 V to 27 V Optimum Operating Range
- Drives High-Side PMOS and Low-Side NMOS in Motor Control or Buck Step-Down Applications
- Output Drive-Voltage Magnitude Limited: <13 V for  $V_{DD}$  up to 30 V
- Biases Each Load Device OFF with a 100 k $\Omega$  Resistor when  $V_{DD}$  Below Operating Level
- Low-Voltage TTL Input Thresholds
- Peak Gate Drives at 12 V: +1.5 A Sink, -1.0 A Source
- Internal Resistors Hold Driver Off When No Inputs Present
- 8-Lead SOIC Package
- Rated from -40°C to +125°C Ambient
- This Device is Pb-Free, Halide Free and is RoHS Compliant

### Applications

- Motor Control with PMOS / NMOS Half-Bridge Configuration
- Buck Converters with High-Side PMOS Device; 100% Duty Cycle Operation Possible
- Logic-Controlled Load Circuits with High-Side PMOS Switch

### MARKING DIAGRAM

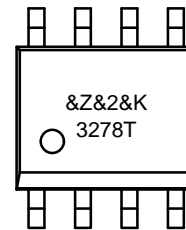

- &Z = Assembly Plant Code
- &2 = 2-Digit Date Code
- &K = 2-Digits Lot Run Traceability Code
- 3278T = Device Code

### ORDERING INFORMATION

See detailed ordering and shipping information on page 12 of this data sheet.

# FAN3278/D

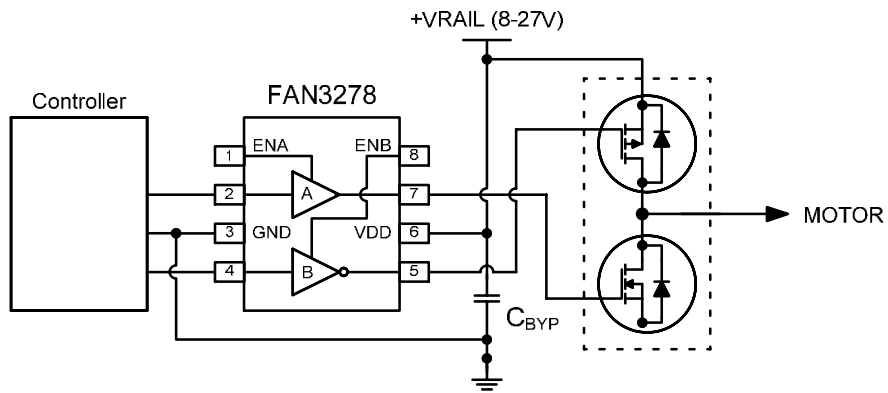

Figure 1. Typical Application

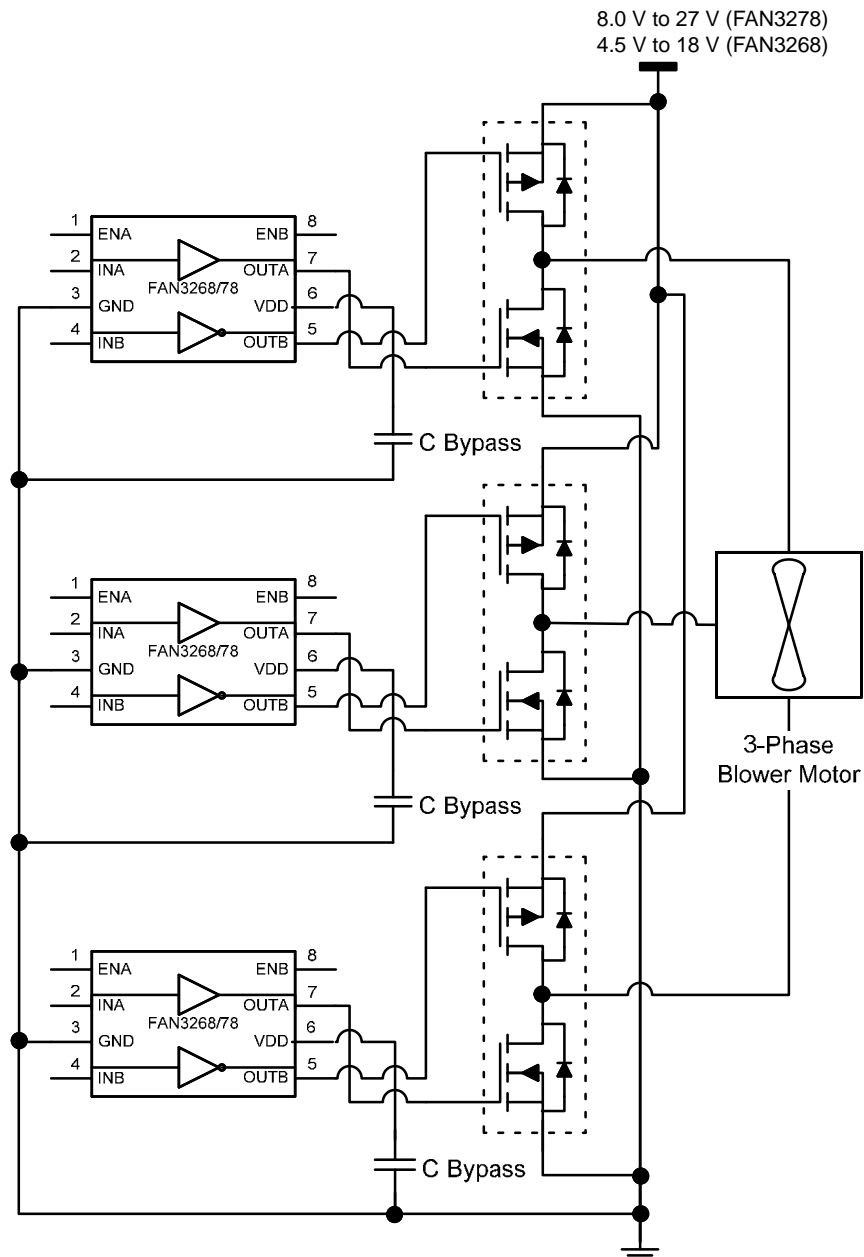

Figure 2. Typical 3-Phase Blower Motor Drive Application

# FAN3278/D

## PIN CONFIGURATION

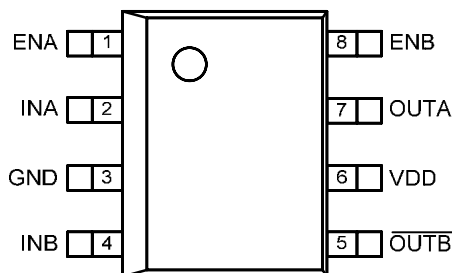

Figure 3. Pin Configuration (Top View)

## THERMAL CHARACTERISTICS (Note 1)

Package	$\Theta_{JL}$ (Note 2)	$\Theta_{JT}$ (Note 3)	$\Theta_{JA}$ (Note 4)	$\Psi_{JB}$ (Note 5)	$\Psi_{JT}$ (Note 6)	Unit
8-Pin Small-Outline Integrated Circuit (SOIC)	40	31	89	43	3	°C/W

- Estimates derived from thermal simulation; actual values depend on the application.
- $\Theta_{JL}$  ( $\Theta_{JL}$ ): Thermal resistance between the semiconductor junction and the bottom surface of all the leads (including any thermal pad) that are typically soldered to a PCB.
- $\Theta_{JT}$  ( $\Theta_{JT}$ ): Thermal resistance between the semiconductor junction and the top surface of the package, assuming it is held at a uniform temperature by a top-side heatsink.
- $\Theta_{JA}$  ( $\Theta_{JA}$ ): Thermal resistance between junction and ambient, dependent on the PCB design, heat sinking, and airflow. The value given is for natural convection with no heatsink, as specified in JEDEC standards JESD51-2, JESD51-5, and JESD51-7, as appropriate.
- $\Psi_{JB}$  ( $\Psi_{JB}$ ): Thermal characterization parameter providing correlation between semiconductor junction temperature and an application circuit board reference point for the thermal environment defined in Note 4. For the SOIC-8 package, the board reference is defined as the PCB copper adjacent to pin 6.
- $\Psi_{JT}$  ( $\Psi_{JT}$ ): Thermal characterization parameter providing correlation between the semiconductor junction temperature and the center of the top of the package for the thermal environment defined in Note 4.

## PIN DEFINITIONS

Pin #	Name	Description
1	ENA	Enable Input for Channel A. Pull pin LOW to inhibit driver A. ENA has TTL thresholds.
8	ENB	Enable Input for Channel B. Pull pin LOW to inhibit driver B. ENB has TTL thresholds.
3	GND	Ground. Common ground reference for input and output circuits.
2	INA	Input to Channel A.
4	INB	Input to Channel B.
7	OUTA	Gate Drive Output A: Held LOW unless required input is present and $V_{DD}$ is above the internal voltage threshold where the IC is functional.
5	OUTB	Gate Drive Output B (inverted from the input). Held HIGH unless the required input is present and $V_{DD}$ is above the internal voltage threshold where the IC is functional.
6	VDD	Supply Voltage. Provides power to the IC.

## OUTPUT LOGIC

FAN3278 (Channel A)		
ENA	INA	OUTA
0	0 (Note 7)	0
0	1	0
1 (Note 7)	0 (Note 7)	0
1 (Note 7)	1	1

FAN3278 (Channel B)		
ENB	INB	OUTB
0	0 (Note 7)	1
0	1	1
1 (Note 7)	0 (Note 7)	1
1 (Note 7)	1	0

- Default input signal if no external connection is made.

# FAN3278/D

## BLOCK DIAGRAM

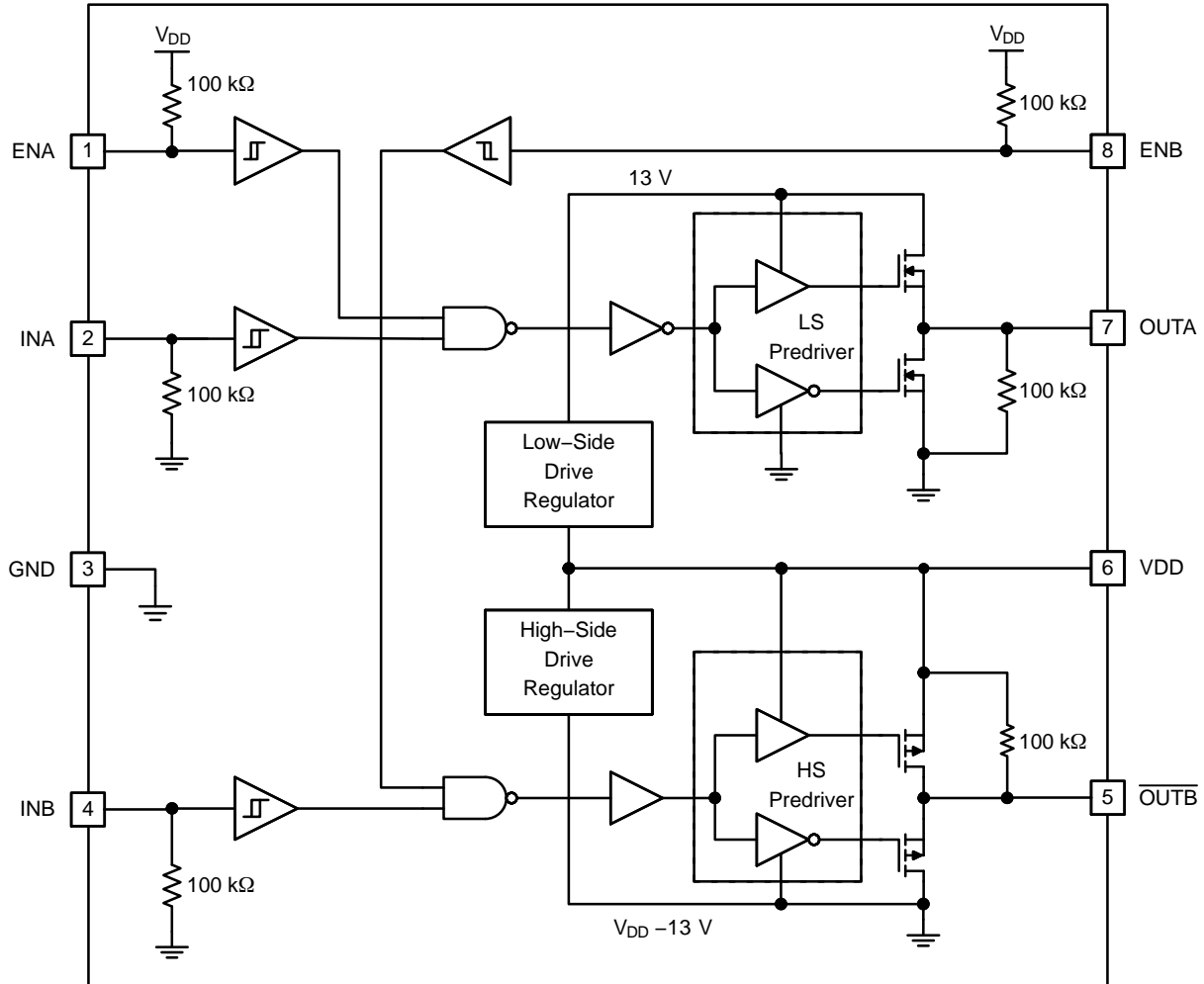

Figure 4. Block Diagram

## ABSOLUTE MAXIMUM RATINGS

Symbol	Parameter	Min	Max	Unit
$V_{DD}$	VDD to PGND	-0.3	30.0	V
$V_{EN}$	ENA, ENB to GND	GND - 0.3	$V_{DD} + 0.3$	V
$V_{IN}$	INA, INB to GND	GND - 0.3	$V_{DD} + 0.3$	V
$V_{OUT}$	OUTA, OUTB to GND	GND - 0.3	$V_{DD} + 0.3$	V
$T_L$	Lead Soldering Temperature (10 Seconds)	-	+260	°C
$T_J$	Junction Temperature	-55	+150	°C
$T_{STG}$	Storage Temperature	-65	+150	°C

Stresses exceeding those listed in the Maximum Ratings table may damage the device. If any of these limits are exceeded, device functionality should not be assumed, damage may occur and reliability may be affected.

# FAN3278/D

## RECOMMENDED OPERATING CONDITIONS

Symbol	Parameter	Min	Max	Unit
V <sub>DD</sub>	Supply Voltage Range	8	27	V
V <sub>EN</sub>	Enable Voltage (ENA, ENB)	0	V <sub>DD</sub>	V
V <sub>IN</sub>	Input Voltage (INA, INB)	0	V <sub>DD</sub>	V
TA	Operating Ambient Temperature	-40	+125	°C

Functional operation above the stresses listed in the Recommended Operating Ranges is not implied. Extended exposure to stresses beyond the Recommended Operating Ranges limits may affect device reliability.

**ELECTRICAL CHARACTERISTICS** (Unless otherwise noted, V<sub>DD</sub> = 12 V and T<sub>J</sub> = -40°C to +125°C. Currents are defined as positive into the device (I<sub>sink</sub>) and negative out of the device (I<sub>source</sub>).)

Symbol	Parameter	Conditions	Min	Typ	Max	Unit
--------	-----------	------------	-----	-----	-----	------

### SUPPLY

V <sub>DD</sub>	Optimum Operating Range (Note 8)		8	-	27	V
I <sub>DD</sub>	Supply Current Inputs / EN Not Connected		-	1.3	2.0	mA
V <sub>ON</sub>	Turn-On Voltage (Note 9)	INA = ENA = V <sub>DD</sub> , INB = ENB = 0 V	-	3.8	-	V
V <sub>HYS</sub>	Turn-On / Turn-Off Hysteresis (Note 9)	INA = ENA = V <sub>DD</sub> , INB = ENB = 0 V	-	10	-	mV

### INPUT (Note 9)

V <sub>IL</sub>	INx Logic Low Threshold		0.8	1.1	-	V
V <sub>IH</sub>	INx Logic High Threshold		-	1.80	2.25	V
V <sub>HYS</sub>	Logic Hysteresis Voltage		0.4	0.7	1.0	V

### ENABLE

V <sub>ENL</sub>	Enable Logic Low Threshold	EN from 5 V to 0 V	0.8	1.2	-	V
V <sub>ENH</sub>	Enable Logic High Threshold	EN from 0 V to 5 V	-	1.60	2.25	V
V <sub>HYS</sub>	Logic Hysteresis Voltage (Note 10)		-	0.7	-	V
R <sub>PU</sub>	Enable Pull-Up Resistance		-	100	-	kΩ
t <sub>D1</sub>	Propagation A Delay, EN Rising (Note 11)	0 - 5 V <sub>IN</sub> , 1 V/ns Slew Rate	-	44	70	ns
t <sub>D2</sub>	Propagation A Delay, EN Falling (Note 11)	0 - 5 V <sub>IN</sub> , 1 V/ns Slew Rate	-	33	60	ns
t <sub>D2</sub>	Propagation B Delay, EN Rising (Note 11)	0 - 5 V <sub>IN</sub> , 1 V/ns Slew Rate	-	39	70	ns
t <sub>D1</sub>	Propagation B Delay, EN Falling (Note 11)	0 - 5 V <sub>IN</sub> , 1 V/ns Slew Rate	-	29	60	ns

### OUTPUT

I <sub>PK_OFF</sub>	OUT Current, Peak, Turn-Off (Note 10)	C <sub>LOAD</sub> = 0.1 μF, f = 1 kHz	-	1.5	-	A
I <sub>PK_ON</sub>	OUT Current, Peak, Turn-On (Note 10)	C <sub>LOAD</sub> = 0.1 μF, f = 1 kHz	-	-1.0	-	A
I <sub>OFF</sub>	OUT Current, Mid-Voltage, Turn-Off (Note 10)	OUT at V <sub>DD</sub> , C <sub>LOAD</sub> = 0.1 μF, f = 1 kHz	-	1.0	-	A
I <sub>ON</sub>	OUT Current, Mid-Voltage, Turn-On (Note 10)	OUT at V <sub>DD</sub> /2, C <sub>LOAD</sub> = 0.1 μF, f = 1 kHz	-	-0.5	-	A
V <sub>OUTA</sub>	OUTA Drive Voltage	V <sub>DD</sub> = 27 V, INA = "HI"	-	11	13	V
V <sub>OUTB</sub>	OUTB Drive Voltage, V <sub>DD</sub> - V <sub>OUTB</sub>	V <sub>DD</sub> = 27 V, INA = "HI"	-	11	13	V
V <sub>OUTA</sub>	OUTA Drive Voltage	V <sub>DD</sub> = 10 V, INB = "HI"	6.5	7.0	-	V
V <sub>OUTB</sub>	OUTB Drive Voltage, V <sub>DD</sub> - V <sub>OUTB</sub>	V <sub>DD</sub> = 10 V, INB = "HI"	6.5	7.0	-	V
R <sub>O_A_SINK</sub>	OUTA Sink Impedance (Turn-Off) (Note 10)	V <sub>DD</sub> = 6 V, C <sub>LOAD</sub> = 0.1 μF	-	4.2	-	Ω
R <sub>O_A_SRC</sub>	OUTA Source Impedance (Turn-On) (Note 10)	V <sub>DD</sub> = 6 V, C <sub>LOAD</sub> = 0.1 μF	-	10.3	-	Ω
R <sub>O_B_SINK</sub>	OUTB Sink Impedance (Turn-On) (Note 10)	V <sub>DD</sub> = 6 V, C <sub>LOAD</sub> = 0.1 μF	-	6.8	-	Ω
R <sub>O_B_SRC</sub>	OUTB Source Impedance (Turn-Off) (Note 10)	V <sub>DD</sub> = 6 V, C <sub>LOAD</sub> = 0.1 μF	-	13.7	-	Ω

# FAN3278/D

**ELECTRICAL CHARACTERISTICS** (Unless otherwise noted,  $V_{DD} = 12\text{ V}$  and  $T_J = -40^\circ\text{C}$  to  $+125^\circ\text{C}$ . Currents are defined as positive into the device ( $I_{\text{sink}}$ ) and negative out of the device ( $I_{\text{source}}$ .) (continued)

Symbol	Parameter	Conditions	Min	Typ	Max	Unit
<b>OUTPUT</b>						
$t_{\text{ON,N}}$	Output A Rise Time (Note 11)	$C_{\text{LOAD}} = 1000\text{ pF}$ to GND	–	17	30	ns
$t_{\text{OFF,N}}$	Output A Fall Time (Note 11)	$C_{\text{LOAD}} = 1000\text{ pF}$ to GND	–	8	15	ns
$t_{\text{ON,P}}$	Output B Fall Time (Note 11)	$C_{\text{LOAD}} = 1000\text{ pF}$ to $V_{DD}$	–	21	30	ns
$t_{\text{OFF,P}}$	Output B Rise Time (Note 11)	$C_{\text{LOAD}} = 1000\text{ pF}$ to $V_{DD}$	–	8	15	ns
$t_{\text{D1}}$	Output Propagation Delay On (Note 11)	$0 - 5 V_{\text{IN}}$ , $1\text{ V/ns}$ Slew Rate	–	45	70	ns
$t_{\text{D2}}$	Output Propagation Delay Off (Note 11)	$0 - 5 V_{\text{IN}}$ , $1\text{ V/ns}$ Slew Rate	–	35	60	ns
$I_{\text{RVS}}$	Output Reverse Current Withstand (Note 10)		–	500	–	mA

Product parametric performance is indicated in the Electrical Characteristics for the listed test conditions, unless otherwise noted. Product performance may not be indicated by the Electrical Characteristics if operated under different conditions.

8. The internal gate-drive regulators provide optimum gate-drive voltage when operating from a rail of 8 V to 27 V. The FAN3278 can be driven from a voltage rail of less than 8 V; however, with reduced gate drive current.

9. EN inputs have near-TTL thresholds (refer to the ENABLE section).

10. Not tested in production.

11. See the Timing Diagrams of Figure 5 and Figure 6.

## TIMING DIAGRAMS

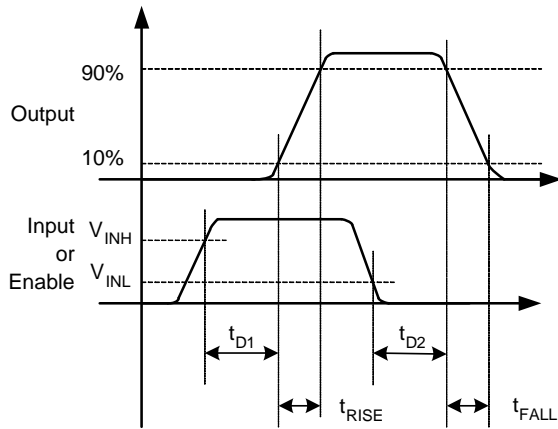

Figure 5. Non-Inverting

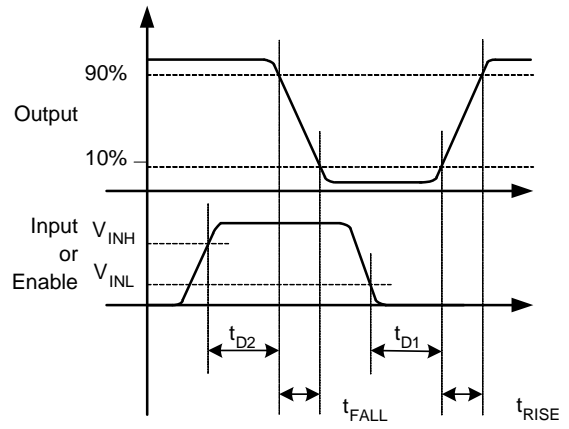

Figure 6. Inverting

**TYPICAL PERFORMANCE CHARACTERISTICS**

(Typical characteristics are provided at  $T_A = 25^\circ\text{C}$  and  $V_{DD} = 12\text{ V}$  unless otherwise noted.)

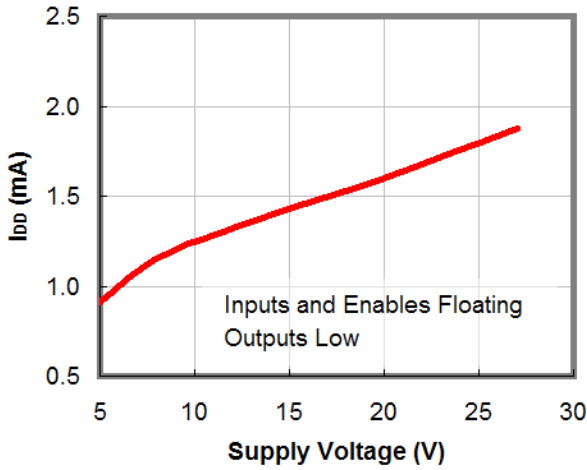

Figure 7.  $I_{DD}$  (Static) vs. Supply Voltage (Note 12)

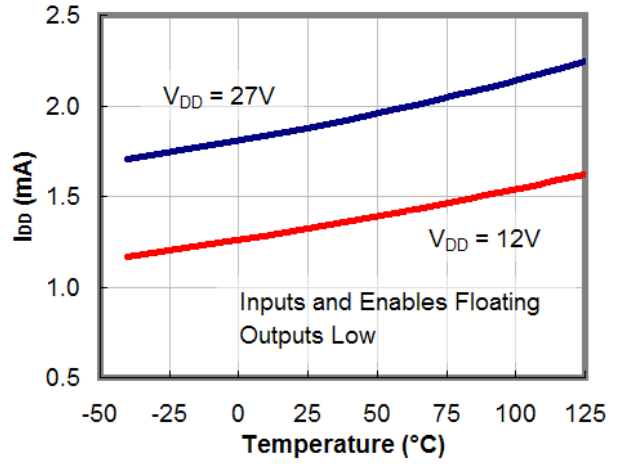

Figure 8.  $I_{DD}$  (Static) vs. Temperature (Note 12)

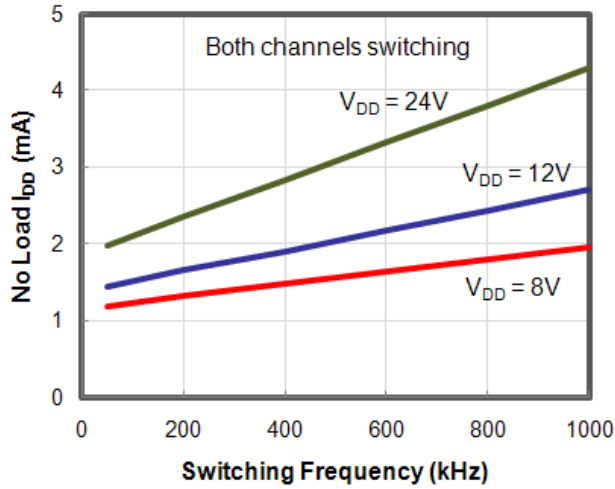

Figure 9.  $I_{DD}$  (No Load) vs. Frequency

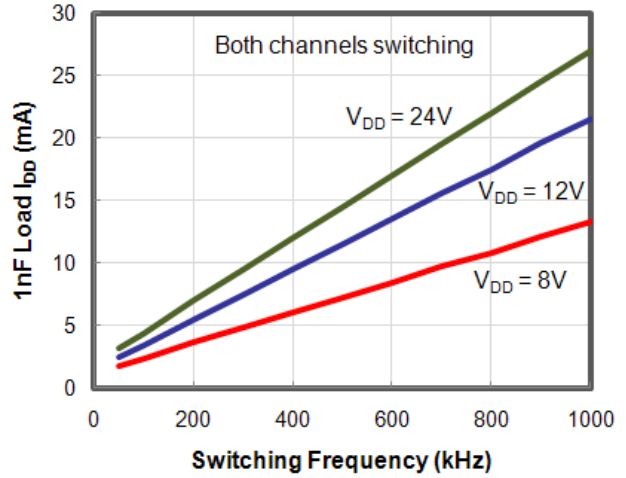

Figure 10.  $I_{DD}$  (1 nF Load) vs. Frequency

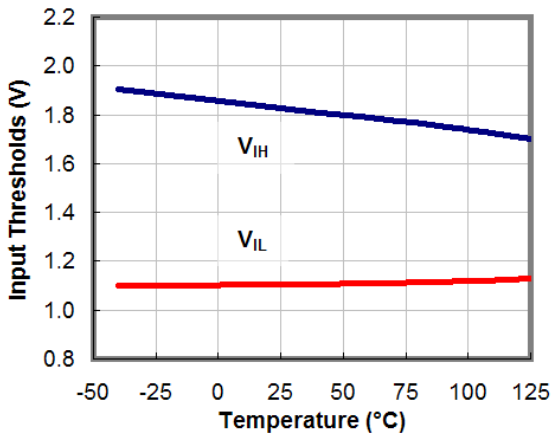

Figure 11. Input Thresholds vs. Temperature

**TYPICAL PERFORMANCE CHARACTERISTICS**

(Typical characteristics are provided at  $T_A = 25^\circ\text{C}$  and  $V_{DD} = 12\text{ V}$  unless otherwise noted.)

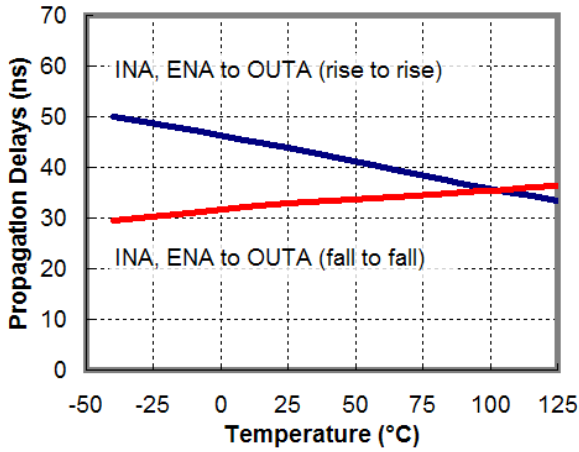

Figure 12. Propagation Delays vs. Temperature

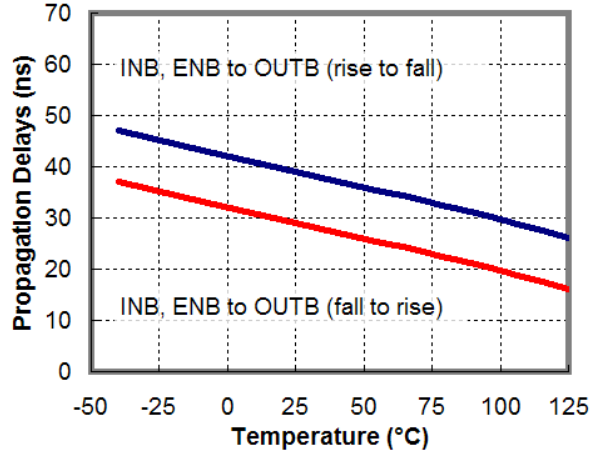

Figure 13. Propagation Delays vs. Temperature

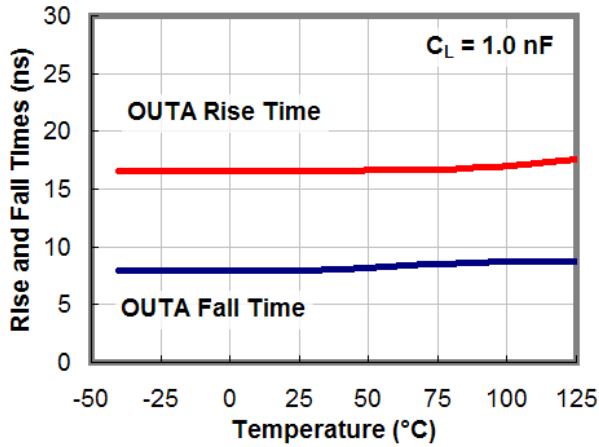

Figure 14. Rise and Fall Times vs. Temperature

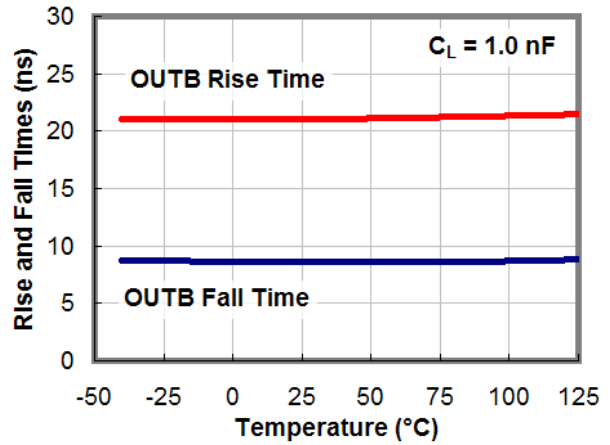

Figure 15. Rise and Fall Times vs. Temperature

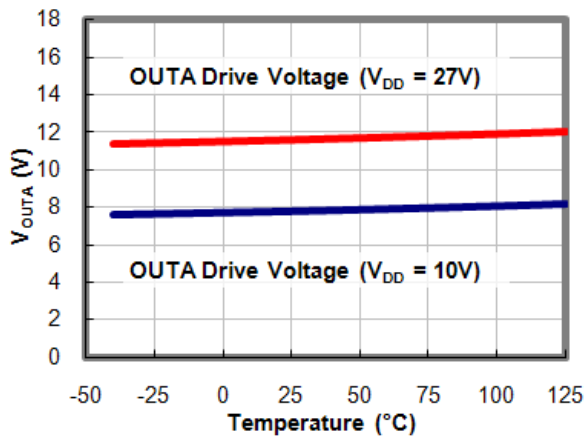

Figure 16. Gate Drive Voltage vs. Temperature

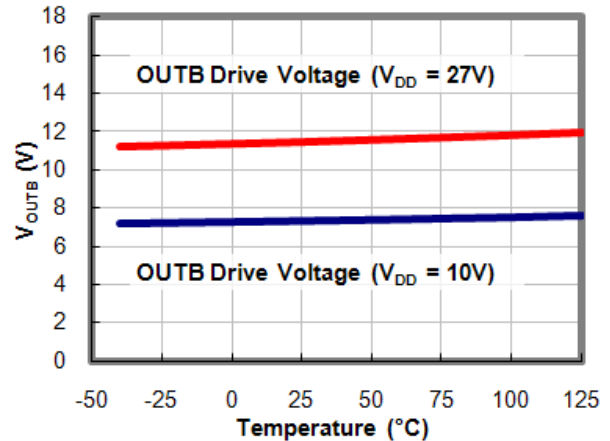

Figure 17. Gate Drive Voltage vs. Temperature

NOTE:

12. For any inverting inputs pulled LOW, non-inverting inputs pulled HIGH, or outputs driven HIGH; static  $I_{DD}$  increases by the current flowing through the corresponding pull-up/down resistor, shown in Figure 4.



## APPLICATIONS INFORMATION

**Input Thresholds**

The FAN3278 driver has TTL input thresholds and provides buffer and level translation functions from logic inputs. The input thresholds meet industry-standard TTL-logic thresholds, independent of the  $V_{DD}$  voltage, and there is a hysteresis voltage of approximately 0.4 V. These levels permit the inputs to be driven from a range of input logic signal levels for which a voltage over 2 V is considered logic HIGH. The driving signal for the TTL inputs should have fast rising and falling edges with a slew rate of 6 V/ $\mu$ s or faster, so a rise time from 0 to 3.3 V should be 550 ns or less. With reduced slew rate, circuit noise could cause the driver input voltage to exceed the hysteresis voltage and retrigger the driver input inadvertently.

**Static Supply Current**

In the  $I_{DD}$  (static) typical performance characteristics (see Figure 7 and Figure 8), the curve is produced with all inputs / enables floating (OUTA is LOW, OUTB is HIGH) and indicates the lowest static  $I_{DD}$  current for the tested configuration. For other states, additional current flows through the 100 k $\Omega$  resistors on the inputs and outputs, shown in the block diagram (see Figure 4). In these cases, the static  $I_{DD}$  current is the value obtained from the curves plus this additional current.

**Gate Drive Regulator**

FAN3278 incorporates internal regulators to regulate the gate drive voltage. The output pin slew rate is determined by this gate drive voltage and the load on the output. It is not user adjustable, but a series resistor can be added if a slower rise or fall time is needed at the MOSFET gate.

**Startup Operation**

The FAN3278 startup logic is optimized to drive a ground-referenced N-channel MOSFET with channel A and a  $V_{DD}$ -referenced P-channel MOSFET with channel B.

The optimum operating voltage of the FAN3278 is 8 V to 27 V. It has an internal “watchdog” circuit that provides a loose UVLO turn-on voltage ( $V_{ON}$ ) of approximately 3.8 V with a small hysteresis of about 10 mV. However, it is recommended that  $V_{DD}$  is greater than 4.75 V in all application circuits.

When the  $V_{DD}$  supply voltage is below the level needed to operate the internal circuitry, the outputs are biased to hold the external MOSFETs in OFF state. Internal 100 k $\Omega$  resistors bias the non-inverting output LOW and the inverting output to  $V_{DD}$  to keep the external MOSFETs off during startup intervals when input control signals may not be present.

Figure 18 shows startup waveforms for non-inverting channel A. At power-up, the driver output for channel A remains LOW until  $V_{DD}$  reaches the voltage where the device starts operating, then OUTA operates in-phase with INA.

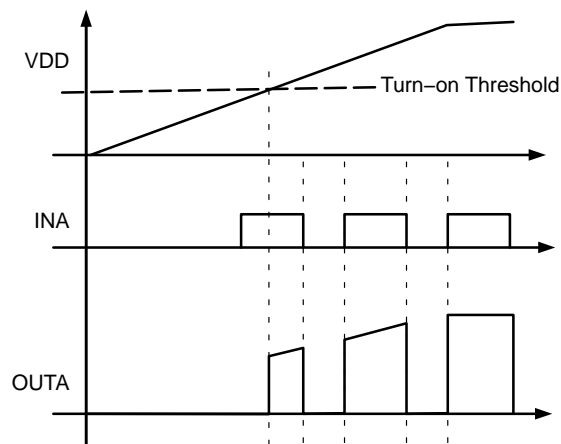

**Figure 18. Non-Inverting Startup Waveforms**

Figure 19 illustrates startup waveforms for inverting channel B. At power-up, the driver output for channel B is tied to  $V_{DD}$  through an internal 100 k $\Omega$  resistor until  $V_{DD}$  reaches the voltage where the device starts operating, then OUTB operates out of phase with INB.

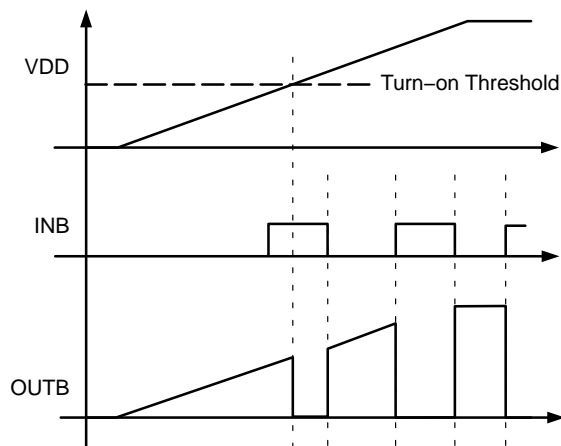

**Figure 19. Inverting Startup Waveforms**

It is possible, during startup, before  $V_{DD}$  has reached approximately 4.5 V, that the output pulse width may take a few switching cycles to reach the full duty-cycle of the input pulse. This is due to internal propagation delays affecting the operation with higher switching frequency (e.g. >100 kHz) and slow  $V_{DD}$  ramp-up (e.g. <20 V/ms). For this reason, it is recommended that  $V_{DD}$  should be greater than 4.75 V before any INA or INB signals are present.

For high-frequency applications (several hundred kHz up to 1 MHz), where the above recommendation of  $V_{DD} > 4.75$  V is not possible, the use of ENABLES to actively hold the outputs LOW until  $V_{DD} > 4.75$  V assures the driver output pulse width follows the input from 4.75 V up to 28 V.

**V<sub>DD</sub> Bypass Capacitor Guidelines**

To enable this IC to turn a device on quickly, a local high-frequency bypass capacitor, C<sub>BYP</sub>, with low ESR and ESL should be connected between the V<sub>DD</sub> and GND pins with minimal trace length. This capacitor is in addition to bulk electrolytic capacitance of 10 μF to 47 μF commonly found on driver and controller bias circuits.

A typical criterion for choosing the value of C<sub>BYP</sub> is to keep the ripple voltage on the V<sub>DD</sub> supply to ≤5%. This is often achieved with a value ≥20 times the equivalent load capacitance C<sub>EQV</sub>, defined as Q<sub>GATE</sub>/V<sub>DD</sub>. Ceramic capacitors of 0.1 μF to 1 μF or larger are common choices, as are dielectrics, such as X5R and X7R, with stable temperature characteristics and high pulse current capability.

If circuit noise affects normal operation, the value of C<sub>BYP</sub> may be increased to 50–100 times the C<sub>EQV</sub> or C<sub>BYP</sub> may be split into two capacitors. One should be a larger value, based on equivalent load capacitance, and the other a smaller value, such as 1–10 nF, mounted closest to the V<sub>DD</sub> and GND pins to carry the higher-frequency components of the current pulses. The bypass capacitor must provide the pulsed current from both of the driver channels and, if the drivers are switching simultaneously, the combined peak current sourced from the C<sub>BYP</sub> can be twice as large as when a single channel is switching.

**Layout and Connection Guidelines**

The FAN3278 gate driver incorporates fast-reacting input circuits, short propagation delays, and powerful output stages capable of delivering current peaks over 1.5 A to facilitate fast voltage transition times. The following layout and connection guidelines are strongly recommended:

- Keep high-current output and power ground paths separate from logic and enable input signals and signal ground paths. This is especially critical when dealing with TTL-level logic thresholds at driver inputs and enable pins.
- Keep the driver as close to the load as possible to minimize the length of high-current traces. This reduces the series inductance to improve high-speed switching, while minimizing the loop area that can couple EMI to the driver inputs and surrounding circuitry.
- If the inputs to a channel are not externally connected, the internal 100 kΩ resistors indicated on block diagrams command a low output on channel A and a high output on channel B. In noisy environments, it may be necessary to tie inputs of an unused channel to V<sub>DD</sub> or GND using short traces to prevent noise from causing spurious output switching.
- Many high-speed power circuits can be susceptible to noise injected from their own output or other external sources, possibly causing output mis-triggering. These effects can be obvious if the circuit is tested in breadboard or non-optimal circuit layouts with long input, enable, or output leads. For best results, make connections to all pins as short and direct as possible.

- The turn-on and turn-off current paths should be minimized, as discussed above.

**Thermal Guidelines**

Gate drivers used to switch MOSFETs and IGBTs at high frequencies can dissipate significant amounts of power. It is important to determine the driver power dissipation and the resulting junction temperature in the application to ensure the part is operating within acceptable temperature limits.

The total power dissipation in a gate driver is the sum of two components, P<sub>GATE</sub> and P<sub>DYNAMIC</sub>:

$$P_{TOTAL} = P_{GATE} + P_{DYNAMIC} \tag{eq. 1}$$

**Gate Driving Loss:** The most significant power loss results from supplying gate current (charge per unit time) to switch the load MOSFET on and off at the switching frequency. The power dissipation that results from driving a MOSFET with a specified gate-source voltage, V<sub>GS</sub>, with gate charge, Q<sub>G</sub>, at switching frequency, f<sub>SW</sub>, is determined by:

$$P_{GATE} = Q_G \cdot V_{GS} \cdot f_{SW} \tag{eq. 2}$$

This needs to be calculated for each P-channel and N-channel MOSFET where the Q<sub>G</sub> is likely to be different.

**Dynamic Pre-drive / Shoot-through Current:** Power loss resulting from internal current consumption under dynamic operating conditions, including pin pull-up / pull-down resistors, can be obtained using the “I<sub>DD</sub> (No-Load) vs. Frequency” graphs in Figure 9 to determine the current I<sub>DYNAMIC</sub> drawn from V<sub>DD</sub> under actual operating conditions.

$$P_{DYNAMIC} = I_{DYNAMIC} \cdot V_{DD} \tag{eq. 3}$$

Once the power dissipated in the driver is determined, the driver junction rise with respect to circuit board can be evaluated using the following thermal equation, assuming ψ<sub>JB</sub> was determined for a similar thermal design (heat sinking and air flow):

$$T_J = P_{TOTAL} \cdot \psi_{JB} + T_B \tag{eq. 4}$$

where:

T<sub>J</sub> = driver junction temperature

ψ<sub>JB</sub> = (psi) thermal characterization parameter relating temperature rise to total power dissipation

T<sub>B</sub> = board temperature in location defined in Note 1 under Thermal Resistance table.

As an example of a power dissipation calculation, consider an application driving two MOSFETs (one P-channel and one N-channel, both with a gate charge of 60 nC each) with V<sub>GS</sub> = V<sub>DD</sub> = 12 V. At a switching frequency of 200 kHz, the total power dissipation is:

$$P_{GATE} = 60 \text{ nC} \cdot 12 \text{ V} \cdot 200 \text{ kHz} \cdot 2 = 0.288 \text{ W} \tag{eq. 5}$$

$$P_{DYNAMIC} = 1.65 \text{ mA} \cdot 12 \text{ V} = 0.020 \text{ W} \tag{eq. 6}$$

$$P_{TOTAL} = 0.308 \text{ W} \tag{eq. 7}$$

## FAN3278/D

The SOIC–8 package has a junction–to–board thermal characterization parameter of  $\psi_{JB} = 43^{\circ}\text{C}/\text{W}$ . In a system application, the localized temperature around the device is a function of the layout and construction of the PCB along with airflow across the surfaces. To ensure reliable operation, the maximum junction temperature of the device must not exceed the absolute maximum rating of  $150^{\circ}\text{C}$ ; with 80% derating,  $T_J$  would be limited to  $120^{\circ}\text{C}$ . Rearranging Equation 4 determines the board temperature required to maintain the junction temperature below  $120^{\circ}\text{C}$ :

$$T_B = T_J - P_{\text{TOTAL}} \cdot \psi_{JB} \quad (\text{eq. 8})$$

$$T_B = 120^{\circ}\text{C} - 0.308 \text{ W} \cdot 43^{\circ}\text{C}/\text{W} = 107^{\circ}\text{C} \quad (\text{eq. 9})$$

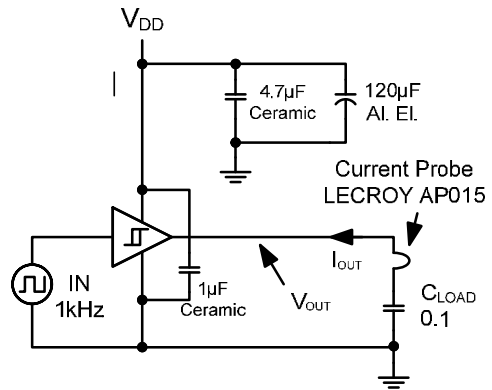

Figure 20. Quasi–Static  $I_{\text{OUT}} / V_{\text{OUT}}$  Test Circuit

### DIFFERENCES BETWEEN FAN3278 AND FAN3268

FAN3278 and FAN3268 are pin–compatible to each other and are designed to drive one P–channel and one N–channel MOSFET in applications such as battery–powered compact

fan / pump DC motor drives. However, there are key differences, highlighted in Table 1.

Table 1. DIFFERENCES BETWEEN FAN3278 AND FAN3268

	FAN3278	FAN3268
<b>Supply Voltage</b>	27 V Operating Maximum 30 V Absolute Maximum	18 V Operating Maximum 20 V Absolute Maximum
<b>Gate Drive Regulator</b>	Yes, since the maximum operating $V_{DD}$ can be as high as 27 V, the gate voltage to the external MOSFETs is limited to about 13 V.	No gate drive regulator is needed. The gate drive voltage is $V_{DD}$ and the FAN3268 switches rail–to–rail.
<b>Minimum Operating Voltage</b>	The optimum operating range is 8 V to 27 V. After the IC turns on at about 3.8 V, the output tracks $V_{DD}$ up to the regulated voltage rail of about 11–13 V. Below 8 V of $V_{DD}$ , the FAN3278 operates, but (a) slower and (b) with limited gate drive voltage until it reaches around 8 V.	4.1 V is the UVLO turn–off voltage which is the minimum operating voltage.
<b>Startup</b>	The IC starts operating approximately at 3.8 V which acts as a loose UVLO threshold. It incorporates a “smart startup” feature where the outputs are held OFF before the IC starts operating.	Has the tight UVLO threshold of 4.5V on / 4.1V off. Incorporates “smart startup” (outputs held OFF before IC is fully operational at the UVLO threshold).
<b>Output Gate Drive Architecture</b>	Standard MOS–based output structure with gate drive clamp.	Compound MillerDrive™ architecture in the final output stage to provide a more efficient gate drive current during the Miller plateau stage of the turn– on/turn–off switching transition.
<b>OUTB Gate Drive Current Strength</b>	Optimized for P–channel: The turn–OFF (1.5 A) is stronger than turn–ON (1.0 A).	P–channel turn–ON (2.4 A) is stronger than turn–OFF (1.6 A).

# FAN3278/D

**Table 2. RELATED PRODUCTS**

Part Number	Type	Gate Drive (Note 13) (Sink / Src)	Input Threshold	Logic	Package
FAN3111C	Single 1 A	+1.1 A / -0.9 A	CMOS	Single Channel of Dual-Input/Single-Output	SOT23-5, MLP6
FAN3111E	Single 1 A	+1.1 A / -0.9 A	External (Note 14)	Single Non-Inverting Channel with External Reference	SOT23-5, MLP6
FAN3100C	Single 2 A	+2.5 A / -1.8 A	CMOS	Single Channel of Two-Input/One-Output	SOT23-5, MLP6
FAN3100T	Single 2 A	+2.5 A / -1.8 A	TTL	Single Channel of Two-Input/One-Output	SOT23-5, MLP6
FAN3226C	Dual 2 A	+2.4 A / -1.6 A	CMOS	Dual Inverting Channels + Dual Enable	SOIC8, MLP8
FAN3226T	Dual 2 A	+2.4 A / -1.6 A	TTL	Dual Inverting Channels + Dual Enable	SOIC8, MLP8
FAN3227C	Dual 2 A	+2.4 A / -1.6 A	CMOS	Dual Non-Inverting Channels + Dual Enable	SOIC8, MLP8
FAN3227T	Dual 2 A	+2.4 A / -1.6 A	TTL	Dual Non-Inverting Channels + Dual Enable	SOIC8, MLP8
FAN3228C	Dual 2 A	+2.4 A / -1.6 A	CMOS	Dual Channels of Two-Input/One-Output, Pin Config.1	SOIC8, MLP8
FAN3228T	Dual 2 A	+2.4 A / -1.6 A	TTL	Dual Channels of Two-Input/One-Output, Pin Config.1	SOIC8, MLP8
FAN3229C	Dual 2 A	+2.4 A / -1.6 A	CMOS	Dual Channels of Two-Input/One-Output, Pin Config.2	SOIC8, MLP8
FAN3229T	Dual 2 A	+2.4 A / -1.6 A	TTL	Dual Channels of Two-Input/One-Output, Pin Config.2	SOIC8, MLP8
FAN3268T	Dual 2 A	+2.4 A / -1.6 A	TTL	Non-Inverting Channel (NMOS) and Inverting Channel (PMOS) + Dual Enables	SOIC8
FAN3278T	Dual 2 A	+1.4 A / -1.0 A	TTL	30 V Non-Inverting (NMOS) and Inverting (PMOS) + Dual Enable	SOIC8
FAN3223C	Dual 4 A	+4.3 A / -2.8 A	CMOS	Dual Inverting Channels + Dual Enable	SOIC8, MLP8
FAN3223T	Dual 4 A	+4.3 A / -2.8 A	TTL	Dual Inverting Channels + Dual Enable	SOIC8, MLP8
FAN3224C	Dual 4 A	+4.3 A / -2.8 A	CMOS	Dual Non-Inverting Channels + Dual Enable	SOIC8, MLP8
FAN3224T	Dual 4 A	+4.3 A / -2.8 A	TTL	Dual Non-Inverting Channels + Dual Enable	SOIC8, MLP8
FAN3225C	Dual 4 A	+4.3 A / -2.8 A	CMOS	Dual Channels of Two-Input/One-Output	SOIC8, MLP8
FAN3225T	Dual 4 A	+4.3 A / -2.8 A	TTL	Dual Channels of Two-Input/One-Output	SOIC8, MLP8
FAN3121C	Single 9 A	+9.7 A / -7.1 A	CMOS	Single Inverting Channel + Enable	SOIC8, MLP8
FAN3121T	Single 9 A	+9.7 A / -7.1 A	TTL	Single Inverting Channel + Enable	SOIC8, MLP8
FAN3122T	Single 9 A	+9.7 A / -7.1 A	CMOS	Single Non-Inverting Channel + Enable	SOIC8, MLP8
FAN3122C	Single 9 A	+9.7 A / -7.1 A	TTL	Single Non-Inverting Channel + Enable	SOIC8, MLP8

13. Typical currents with OUT at 6 V and  $V_{DD} = 12$  V.

14. Thresholds proportional to an externally supplied reference voltage.

## ORDERING INFORMATION

Part Number	Logic	Input Threshold	Package Type	Shipping†
FAN3278TMX	Non-Inverting Channel and Inverting Channel with Dual Enable	TTL	SOIC8 (Pb-Free, Halide Free)	2500 / Tape & Reel

†For information on tape and reel specifications, including part orientation and tape sizes, please refer to our Tape and Reel Packaging Specifications Brochure, BRD8011/D.

MillerDrive is trademark of Semiconductor Components Industries, LLC dba "onsemi" or its affiliates and/or subsidiaries in the United States and/or other countries.

**MECHANICAL CASE OUTLINE**  
**PACKAGE DIMENSIONS**

ON Semiconductor®



**SOIC8**  
**CASE 751EB**  
**ISSUE A**

DATE 24 AUG 2017

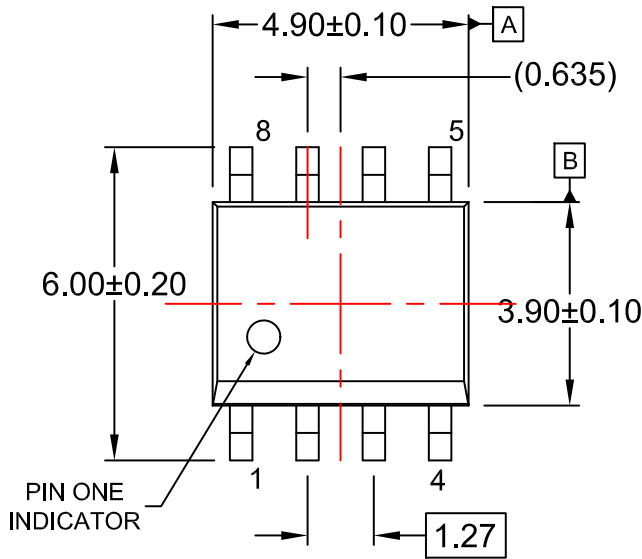

⊕ 0.25 (M) C B A

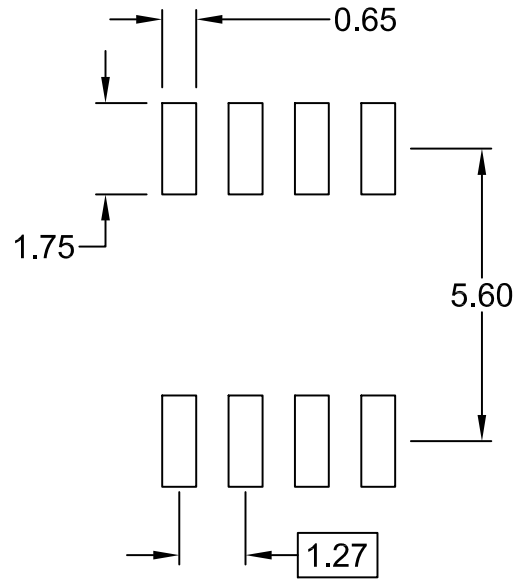

LAND PATTERN RECOMMENDATION

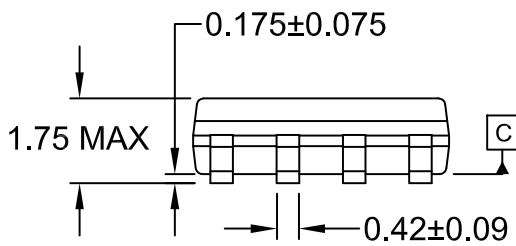

⌒ 0.10

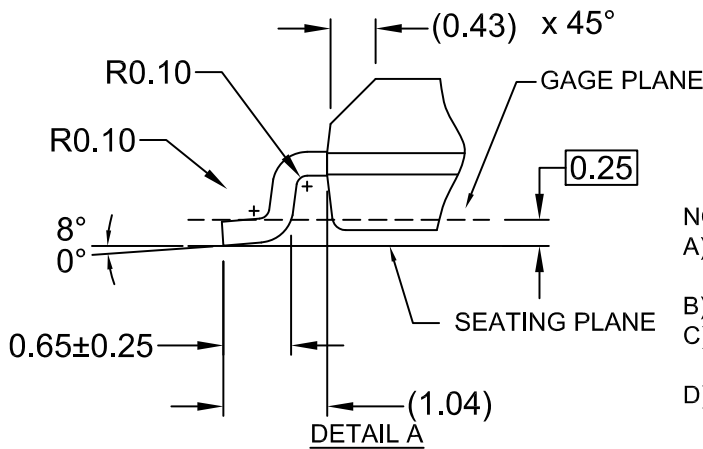
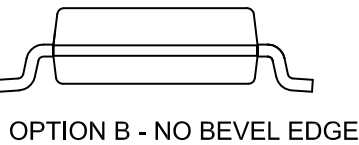
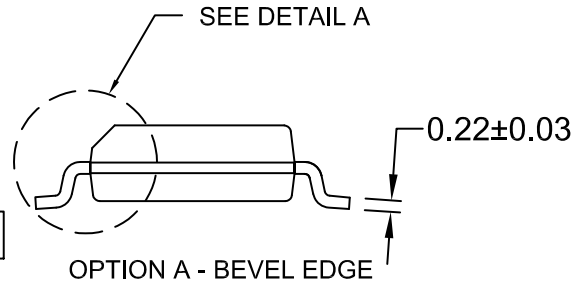

SCALE: 2:1

**NOTES:**

- A) THIS PACKAGE CONFORMS TO JEDEC MS-012, VARIATION AA.
- B) ALL DIMENSIONS ARE IN MILLIMETERS.
- C) DIMENSIONS DO NOT INCLUDE MOLD FLASH OR BURRS.
- D) LANDPATTERN STANDARD: SOIC127P600X175-8M

<b>DOCUMENT NUMBER:</b>	<b>98AON13735G</b>	Electronic versions are uncontrolled except when accessed directly from the Document Repository. Printed versions are uncontrolled except when stamped "CONTROLLED COPY" in red.
<b>DESCRIPTION:</b>	<b>SOIC8</b>	<b>PAGE 1 OF 1</b>

ON Semiconductor and are trademarks of Semiconductor Components Industries, LLC dba ON Semiconductor or its subsidiaries in the United States and/or other countries. ON Semiconductor reserves the right to make changes without further notice to any products herein. ON Semiconductor makes no warranty, representation or guarantee regarding the suitability of its products for any particular purpose, nor does ON Semiconductor assume any liability arising out of the application or use of any product or circuit, and specifically disclaims any and all liability, including without limitation special, consequential or incidental damages. ON Semiconductor does not convey any license under its patent rights nor the rights of others.

**onsemi**, **Onsemi**, and other names, marks, and brands are registered and/or common law trademarks of Semiconductor Components Industries, LLC dba "**onsemi**" or its affiliates and/or subsidiaries in the United States and/or other countries. **onsemi** owns the rights to a number of patents, trademarks, copyrights, trade secrets, and other intellectual property. A listing of **onsemi**'s product/patent coverage may be accessed at [www.onsemi.com/site/pdf/Patent-Marking.pdf](http://www.onsemi.com/site/pdf/Patent-Marking.pdf). **onsemi** reserves the right to make changes at any time to any products or information herein, without notice. The information herein is provided "as-is" and **onsemi** makes no warranty, representation or guarantee regarding the accuracy of the information, product features, availability, functionality, or suitability of its products for any particular purpose, nor does **onsemi** assume any liability arising out of the application or use of any product or circuit, and specifically disclaims any and all liability, including without limitation special, consequential or incidental damages. Buyer is responsible for its products and applications using **onsemi** products, including compliance with all laws, regulations and safety requirements or standards, regardless of any support or applications information provided by **onsemi**. "Typical" parameters which may be provided in **onsemi** data sheets and/or specifications can and do vary in different applications and actual performance may vary over time. All operating parameters, including "Typicals" must be validated for each customer application by customer's technical experts. **onsemi** does not convey any license under any of its intellectual property rights nor the rights of others. **onsemi** products are not designed, intended, or authorized for use as a critical component in life support systems or any FDA Class 3 medical devices or medical devices with a same or similar classification in a foreign jurisdiction or any devices intended for implantation in the human body. Should Buyer purchase or use **onsemi** products for any such unintended or unauthorized application, Buyer shall indemnify and hold **onsemi** and its officers, employees, subsidiaries, affiliates, and distributors harmless against all claims, costs, damages, and expenses, and reasonable attorney fees arising out of, directly or indirectly, any claim of personal injury or death associated with such unintended or unauthorized use, even if such claim alleges that **onsemi** was negligent regarding the design or manufacture of the part. **onsemi** is an Equal Opportunity/Affirmative Action Employer. This literature is subject to all applicable copyright laws and is not for resale in any manner.

---

## ADDITIONAL INFORMATION

### TECHNICAL PUBLICATIONS:

Technical Library: [www.onsemi.com/design/resources/technical-documentation](http://www.onsemi.com/design/resources/technical-documentation)  
onsemi Website: [www.onsemi.com](http://www.onsemi.com)

### ONLINE SUPPORT: [www.onsemi.com/support](http://www.onsemi.com/support)

For additional information, please contact your local Sales Representative at [www.onsemi.com/support/sales](http://www.onsemi.com/support/sales)