

THIS DRAWING IS UNPUBLISHED. RELEASED FOR PUBLICATION  
 © COPYRIGHT - By - ALL RIGHTS RESERVED.

REVISIONS					
P	LTR	DESCRIPTION	DATE	DWN	APVD
	N1	REVISED PER ECR-19-012985	20AUG2019	ED	RS

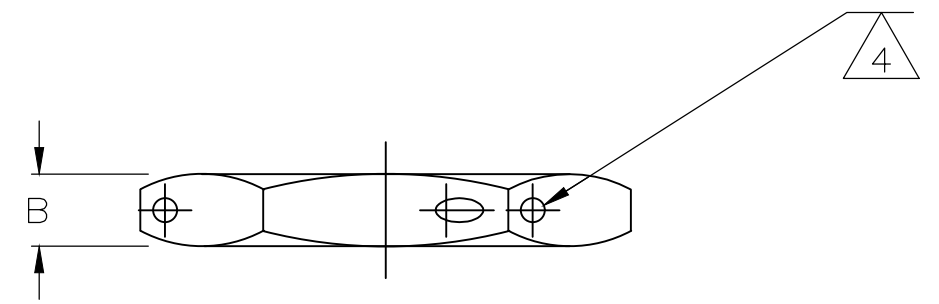
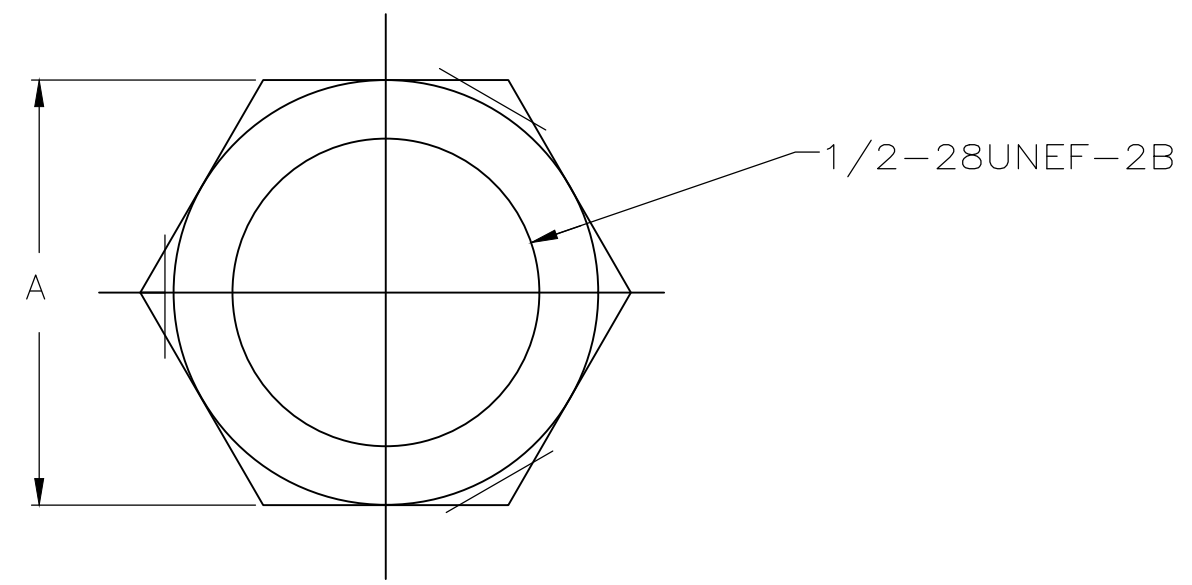

- ① BRASS PER QQ-B-627.
- ② SILVER PLATE PER QQ-S-365, 5.08µm[.000200] MINIMUM THICK.
- ③ NICKEL PLATE PER QQ-N-290, 2.54µm[.000100] MINIMUM THICK.
- ④  $\phi 0.79 \pm 0.08$  [.031±.003] (3 HOLES) 120° APART.
- ⑤ GOLD PLATE PER MIL-G-45204, 0.51µm[.000020] MINIMUM THICK.
- ⑥ SILVER PLATE PER QQ-S-365, 2.54µm[.000100] MINIMUM THICK.
- ⑦ 10PCS PER LABELED BAG, 100 BAGS PER LABELED INNER CARTON(1000) AND 10 INNER CARTONS(10000) PER SHIP BOX.

⑦	2.39±0.15[.094±.006]	14.10±0.25[.555±.010]		③	①	9-329631-3
	2.77[.109]	15.88[.625]		②	①	9-329631-2
	2.39±0.15[.094±.006]	14.10±0.25[.555±.010]	④	⑥	①	9-329631-1
	2.39±0.15[.094±.006]	14.10±0.25[.555±.010]		⑥	①	9-329631-0
	2.77[.109]	15.88[.625]		⑤	①	2-329631-2
	2.39±0.15[.094±.006]	14.10±0.25[.555±.010]		③	①	2-329631-1
	2.77[.109]	15.88[.625]		③	①	2-329631-0
	2.77[.109]	15.88[.625]		②	①	1-329631-9
	2.39±0.15[.094±.006]	14.10±0.25[.555±.010]	④	⑥	①	1-329631-7
	2.39±0.15[.094±.006]	14.10±0.25[.555±.010]		③	①	1-329631-2
	2.39±0.15[.094±.006]	14.10±0.25[.555±.010]		⑥	①	329631
	B	A	HOLES	FINISH	MATERIAL	PART NUMBER

THIS DRAWING IS A CONTROLLED DOCUMENT.		DWN P. ALSEDEK 16MAY90	<b>STE</b> TE Connectivity			
DIMENSIONS: mm [INCHES]		CHK R.E. RUTH 06SEP90				
TOLERANCES UNLESS OTHERWISE SPECIFIED:		APVD M. PHILLIPS 20SEP90	NAME JAM NUT			
0 PLC ± -		PRODUCT SPEC	-			
1 PLC ± -		APPLICATION SPEC	-			
2 PLC ± 0.13[.005]		WEIGHT 0.000000	SIZE A3	CAGE CODE 00779	DRAWING NO C-329631	RESTRICTED TO -
3 PLC ± -		CUSTOMER DRAWING				
4 PLC ± -		SCALE 4:1	SHEET 1 OF 1		REV N1	
ANGLES ± -						
FINISH ② & ③						