

THIS DRAWING IS UNPUBLISHED. RELEASED FOR PUBLICATION
 © COPYRIGHT - By - ALL RIGHTS RESERVED.

LOC		DIST		REVISIONS			
P	LTR	DESCRIPTION		DATE	DWN	APVD	
C		OBSOLETE ECO-09-014329		28Jul2009	YS.H	BH.Y	
D		CHANGE LOGO&ADD LINE IDENTIFICATION ECO-12-003498 & ADD CQC SYMBOL P-11-003756		08Nov2012	YS.H	BH.Y	

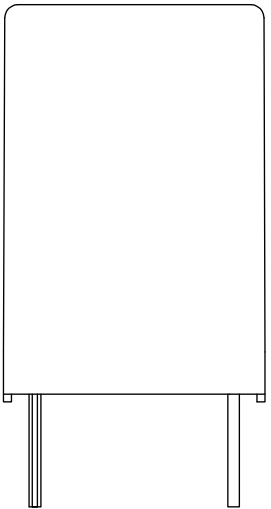

CONNECTION DIAGRAM (BOTTOM VIEW)

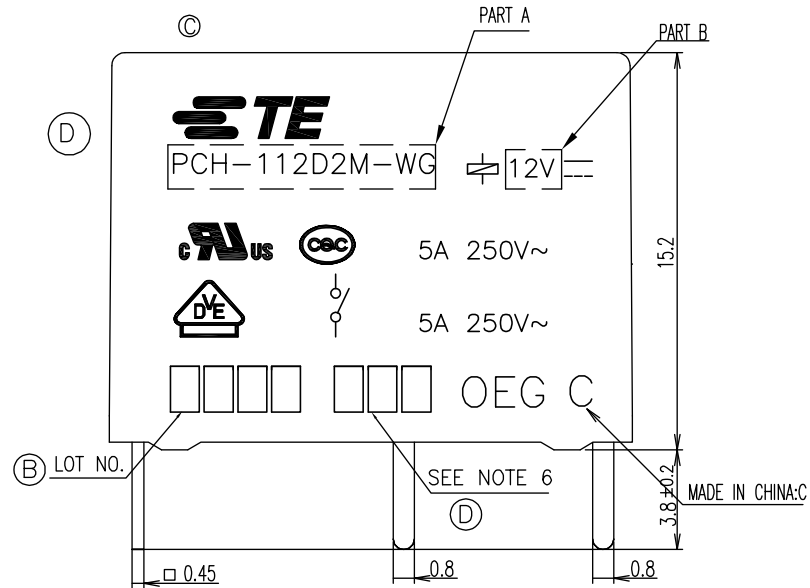
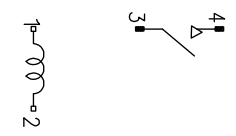

DRILLING DIAGRAM (BOTTOM VIEW)

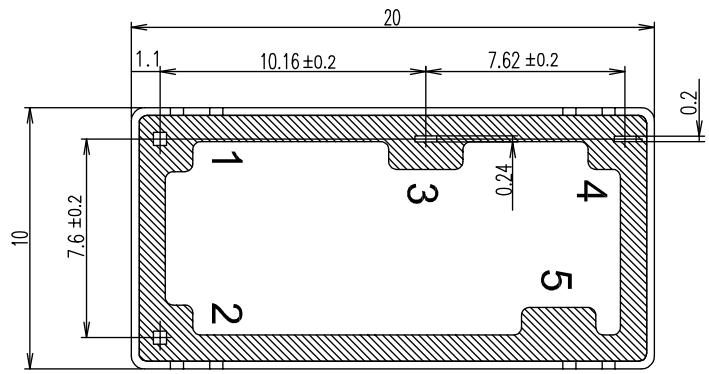
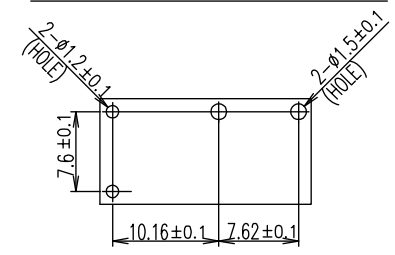

Diagram dimension	Tolerance
0.99mm max.	±0.1mm
1 - 2.99mm	±0.2mm
3mm min.	±0.3mm

THIS DRAWING IS A CONTROLLED DOCUMENT.		DWN	KY.DU		TE Connectivity							
DIMENSIONS: mm		CHK	N.Funayama									
		TOLERANCES UNLESS OTHERWISE SPECIFIED:		APVD	NAME							
		0 PLC ± -	1 PLC ± -	C.H.Hsu		PCH-D2M(H)-WG CUSTOMER DRAWING						
MATERIAL		FINISH		PRODUCT SPEC	SIZE							
-		-		-		CAGE CODE	DRAWING NO	RESTRICTED TO				
				A3		00779	C=1721767	-				
CUSTOMER DRAWING				WEIGHT	-		SCALE	5:1	SHEET	1 of 2	REV	D

THIS DRAWING IS UNPUBLISHED. RELEASED FOR PUBLICATION
 © COPYRIGHT - By - ALL RIGHTS RESERVED.

LOC	DIST	REVISIONS					
HB	-	P	LTR	DESCRIPTION	DATE	DWN	APVD
		-		SEE SHEET 1	-	-	-

1-1721767-4	PCH-148D2MH-WG	48V	PCH-148D2M-WG	n	OBSOLETE
1-1721767-3	PCH-124D2MH-WG	24V	PCH-124D2M-WG	m	OBSOLETE
1-1721767-2	PCH-112D2MH-WG	12V	PCH-112D2M-WG	l	OBSOLETE
1-1721767-1	PCH-109D2MH-WG	9V	PCH-109D2M-WG	k	OBSOLETE
1-1721767-0	PCH-106D2MH-WG	6V	PCH-106D2M-WG	j	OBSOLETE
1721767-9	PCH-105D2MH-WG	5V	PCH-105D2M-WG	i	OBSOLETE
1721767-8	PCH-103D2MH-WG	3V	PCH-103D2M-WG	h	OBSOLETE
1721767-7	PCH-148D2M-WG	48V	PCH-148D2M-WG	g	ACTIVE
1721767-6	PCH-124D2M-WG	24V	PCH-124D2M-WG	f	ACTIVE
1721767-5	PCH-112D2M-WG	12V	PCH-112D2M-WG	e	ACTIVE
1721767-4	PCH-109D2M-WG	9V	PCH-109D2M-WG	d	ACTIVE
1721767-3	PCH-106D2M-WG	6V	PCH-106D2M-WG	c	ACTIVE
1721767-2	PCH-105D2M-WG	5V	PCH-105D2M-WG	b	ACTIVE
1721767-1	PCH-103D2M-WG	3V	PCH-103D2M-WG	a	OBSOLETE
TE PART NO	TE TYPE NAME	PART B	PART A	TYPE	P/N STATUS

RELAY TYPE

©

NOTES:

- 1.LAST SUFFIX NON : WASHABLE TYPE
- ② 2.LOT NO SYSTEM AS FOLLOWING:



- ③ 3.TERMINAL DIMENSION IS BEFORE SOLDER DIP;
- ④ 4.FOR THE TIN-PLATING OF THE PINS:
+0.1mm FOR WIDTH, THICKNESS AND DIAMETER.
+0.5mm FOR LENGTH.
- ⑤ 5.MARKING FROM INK TO LASER.

- ⑥ 6.ADD LOT NO. SYSTEM AS FOLLOWING;



- I, DIGITS FOR DAY OF THE WEEK
1...MONDAY IN THIS WEEK;
2...TUESDAY IN THIS WEEK;
.....
7...SUNDAY IN THIS WEEK
- II, DIGITS FOR SHIFT OF THE DAY
1...DAY SHIFT IN THIS DAY;
2...NIGHT SHIFT IN THIS DAY;
- III, ONE CHARACTER DISTINGUISH THE LINE IDENTITY, SUCH AS: A,B,....Z

		UV RESIN	UV SEAL	16
		EPOXY RESIN	SEAL	15
CLASS F (A)		MW79 (A)	MAGNETIC WIRE	14
	SOLDER DIP	CP WIRE	COIL TERMINAL	13
		Ag ALLOY	STATIONARY CONTACT	12
		Ag ALLOY	MOVABLE CONTACT	11
		Cu ALLOY	HINGE SPRING	10
	SOLDER DIP	Cu ALLOY	NO TERMINAL	9
	SOLDER DIP	Cu ALLOY	MOVABLE SPRING	8
UL 94V-0		LCP	CARD	7
UL 94V-0		PET	CASE	6
UL 94HB		PA NYLON	BOBBIN	5
UL 94V-0		PET	BASE	4
		Ni PLATED	STEEL CORE	3
		CuNi PLATED	STEEL ARMATURE	2
		CuNi PLATED	STEEL YOKE	1
INCOMBUSTIBILITY	TREATMENT	MATERIAL	DESCRIPTION	ITEM

THIS DRAWING IS A CONTROLLED DOCUMENT.		DWN	KY.DU	
		CHK	-	
		APVD	N.Funayama	
DIMENSIONS: mm		PRODUCT SPEC	NAME	
TOLERANCES UNLESS OTHERWISE SPECIFIED:		APPLICATION SPEC	PCH-D2M(H)-WG CUSTOMER DRAWING	
0 PLC ± -		WEIGHT	SIZE	CAGE CODE
1 PLC ± -			A3	00779
2 PLC ± -			DRAWING NO	RESTRICTED TO
3 PLC ± -			C=1721767	-
4 PLC ± -			SCALE	SHEET
ANGLES ± -			5:1	2 of 2
FINISH			REV	D
MATERIAL		CUSTOMER DRAWING		

