

8E1911CS  
(DRAWING NO.) 台異異図

VER.	DATE	CN NO.	DESCRIPTION	DR.	CHK.	APPD.	APPD.
2	23/FEB/2016	016435	ADDED ITEM	T. NAKAMURA	T. KOBUCHI	T. NISHIMURA	H. OBIKANE

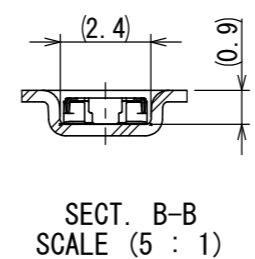
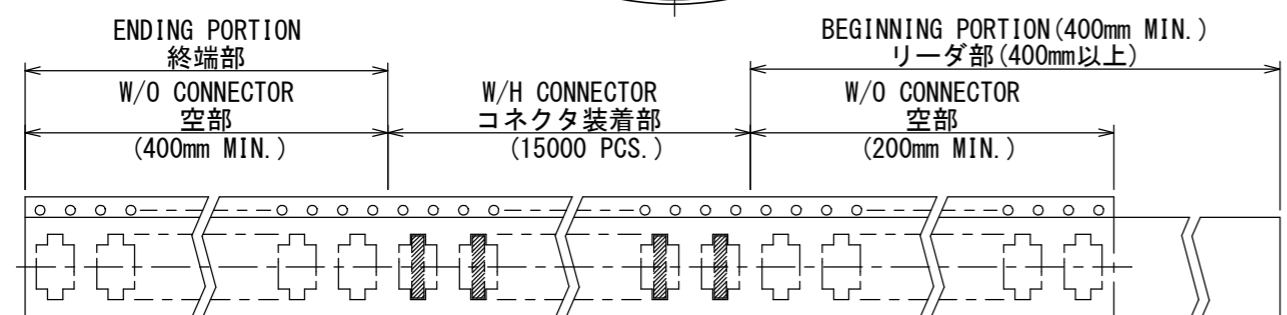
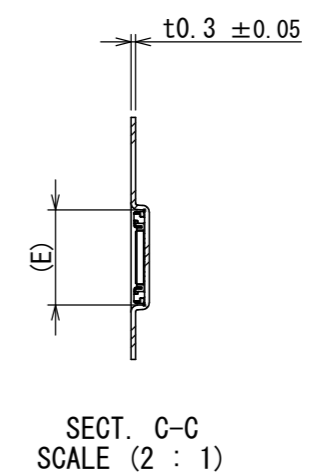
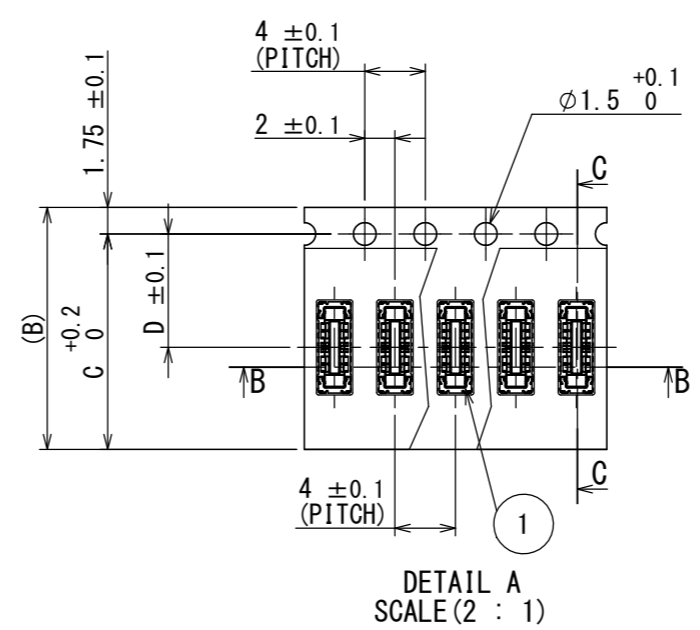
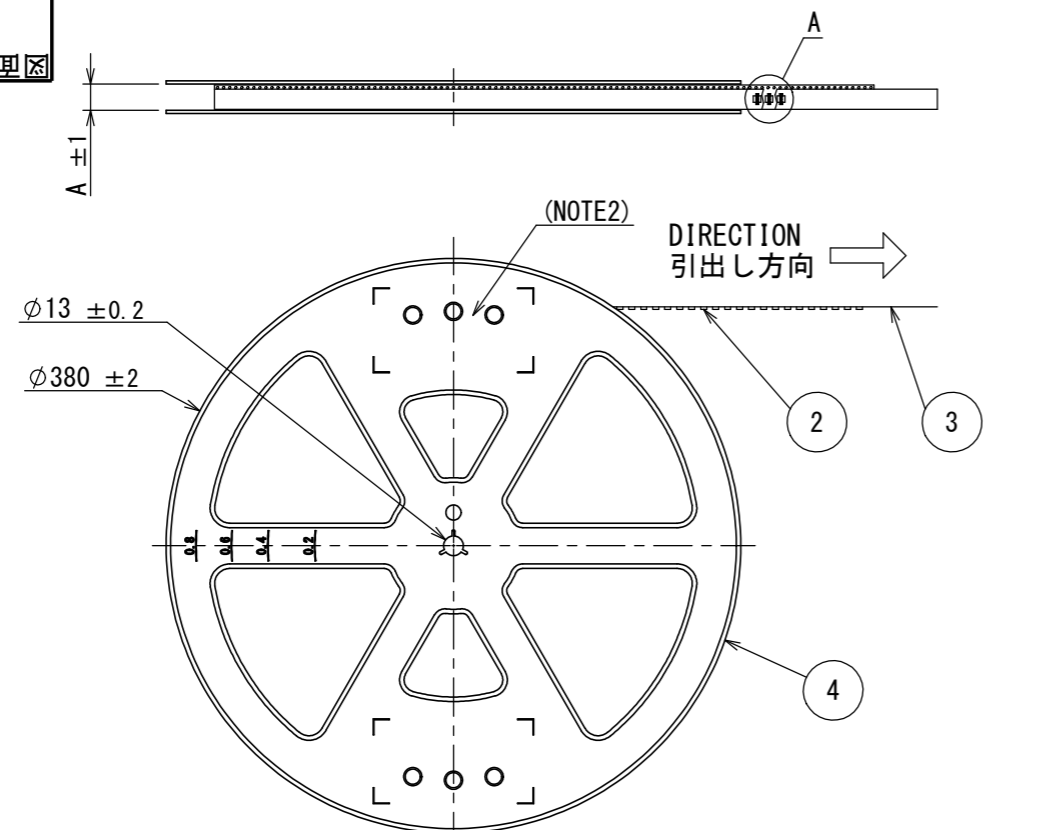

TABLE 1

NUMBER OF CONTACT 芯数	DIMENSIONS 寸法				
	A	(B)	C	D	(E)
2	17.4	16	14.25	7.5	5.88
4	17.4	16	14.25	7.5	6.28

NOTE1. SUFFIX "-R15000" OF THE PART NUMBER INDICATES THAT 15000 PCS. OF WP10-S\*\*\*VA10 CONNECTORS ARE ACCOMMODATED IN ONE REEL.  
 NOTE2. THE LABEL, IN WHICH PART NO., NO. OF CONNECTORS, LOT NO., TAPE WIDTH AND FEED PITCH ARE MARKED IS TO BE ATTACHED ON THE REEL AS SHOWN.  
 NOTE3. REFER TO THE DRAWING, SJ116137 (TITLE: WP10-S\*\*\*VA10) FOR THE DIMENSIONS OF THE CONNECTOR.  
 NOTE4. LOT NO. IS MARKED AS SHOWN IN BELOW FIGURE MARKING.

注1. "WP10-S\*\*\*VA10-R15000"は収納数15000個入りのリールに収納された品名を表す。  
 注2. 図示の位置に右記のシールを貼り、品名、収納数、ロットNo. 及び、テープの幅と送りピッチを記入する。  
 注3. コネクタ寸法は、SJ116137 (WP10-S\*\*\*VA10)を参照のこと。  
 注4. ロットNo. を表示する、表示方法は下記による。

(EX.) 15 03 24

MANUFACTURE YEAR.  
製造西暦

MANUFACTURE MONTH.  
製造月

MANUFACTURE DAY.  
製造日

現品ラベル/ARTICLE LABEL

品名 (DESCRIPTION) WP10-S\*\*\*VA10-R15000  
 図番 (PART No.) SJ116138  
 数量 (Qty) 15000  
 ITEM NO.  
 Lot No.  
 E.Code: TB\*\*04

XXXXXXXX XX XX XXXX XXXX  
 Count: 001  
 JAE001

2015/03/24  
 MADE IN JAPAN  
 QCF-C-0628 (07.12)/JAPS-9006-2

4	REEL リール	—	PS	—	—
3	COVER TAPE カバーテープ	—	PET	—	—
2	CARRIER TAPE キャリアテープ	1	PS	—	—
1	CONNECTOR コネクタ	15000	—	—	WP10-S***VA10 SJ116137 (NOTE3)
符号 NO.	名 称 DESCRIPTION	個 数 QTY.	材 料 MATERIAL	仕 上 FINISH	備 考 REMARKS

仕様書 (SPECIFICATION) JACS-11080	第1版 (ORIGINAL DATE) 02/APR/2015	尺度 (SCALE) 1:5	シリーズ (SERIES) WP10	日本航空電子工業株式会社
一般公差 (GENERAL TOLERANCE) 寸法 (DIMENSION)	製図 DR. —	名称 (TITLE) WP10-S***VA10-R15000 RECEPTACLE CONNECTOR		JAE JAPAN AVIATION ELECTRONICS INDUSTRY, LTD.
角度 (ANGLES)	担当 CHK. Y. HONMA	質量 (MASS)		
単位 (UNIT) : mm	査閲 APPD. T. NISHIMURA	図面番号 (DRAWING NO.) SJ116138		版数 (VER.) 2
	承認 APPD. H. OBIKANE			

DCF-C-212H(12.08)

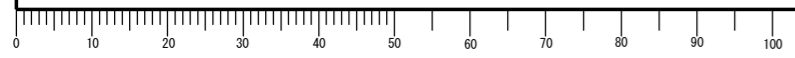

WISDOM承認 2016/02/29