

- PREFIX AND SUFFIX NUMBERS MUST MATCH THOSE ON PLUG ASSEMBLY FOR PARTS TO MATE.
- POLYESTER, FLAME RETARDANT, UL 94V-0 RATED, GLASS FILLED, BLACK.
- 3.81µm [.000150] MIN BRIGHT TIN OVER 1.27µm [.000050] MIN NICKEL.
- 1.27µm [.000050] MIN GOLD ON MATING SURFACE FOR A LENGTH OF 2.54 [.100] MIN, 3.81µm [.000150] MIN MATTE TIN ON OPPOSITE END FOR A LENGTH OF 3.81 [.150] MIN, BOTH OVER 1.27µm [.000050] MIN NICKEL ON ENTIRE CONTACT.
- POINT OF PLATING MEASUREMENT.
- DIMENSION INDICATES MATING AREA.

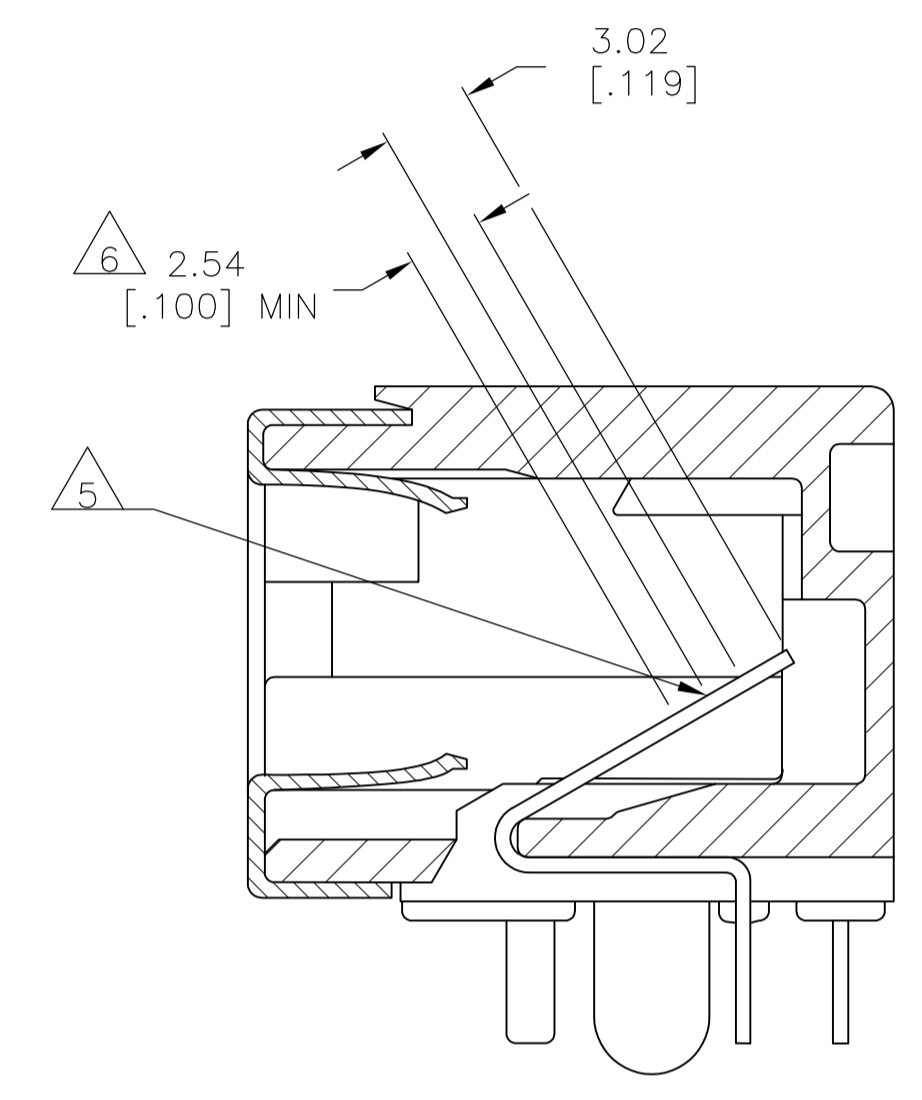

SECTION J-J

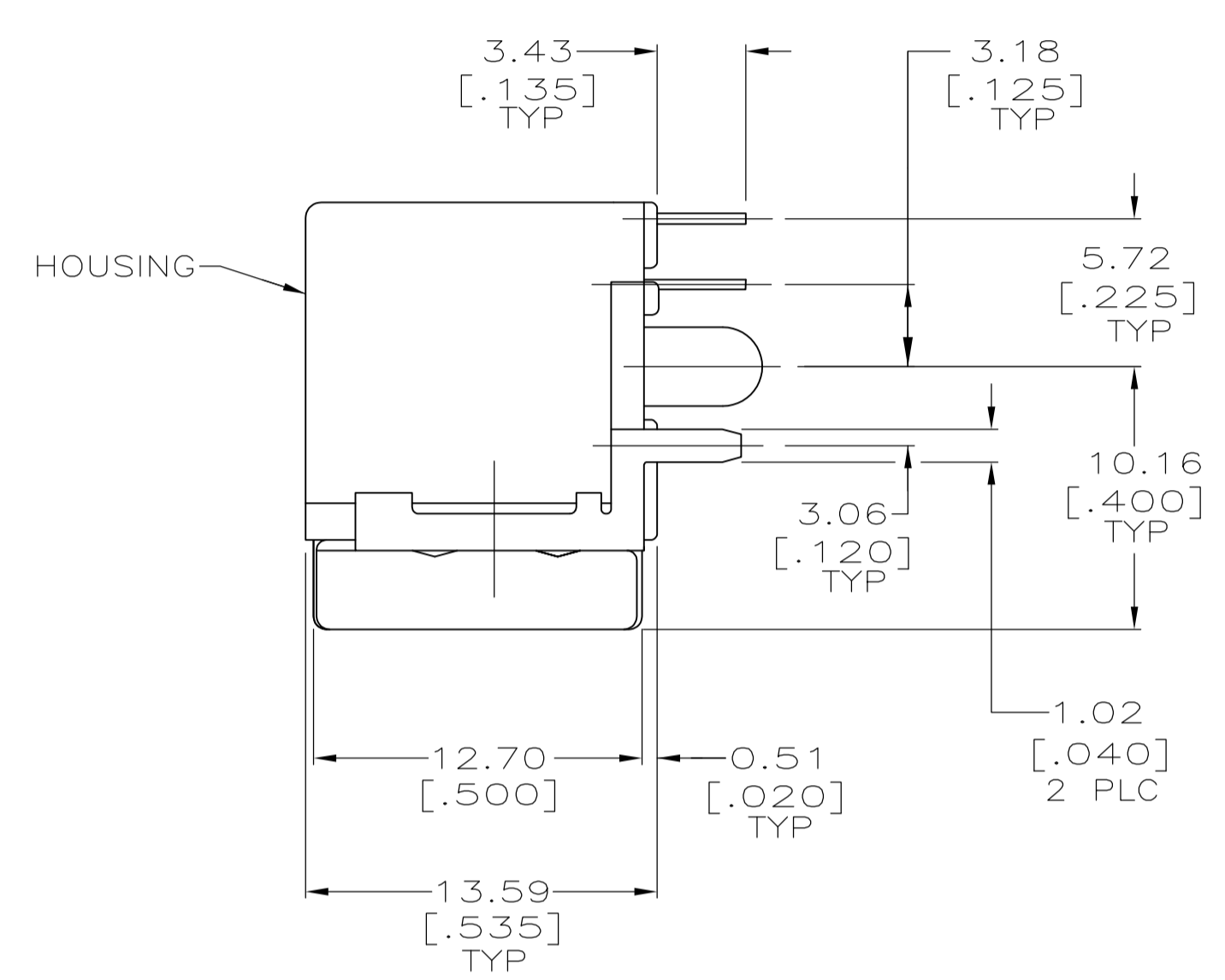
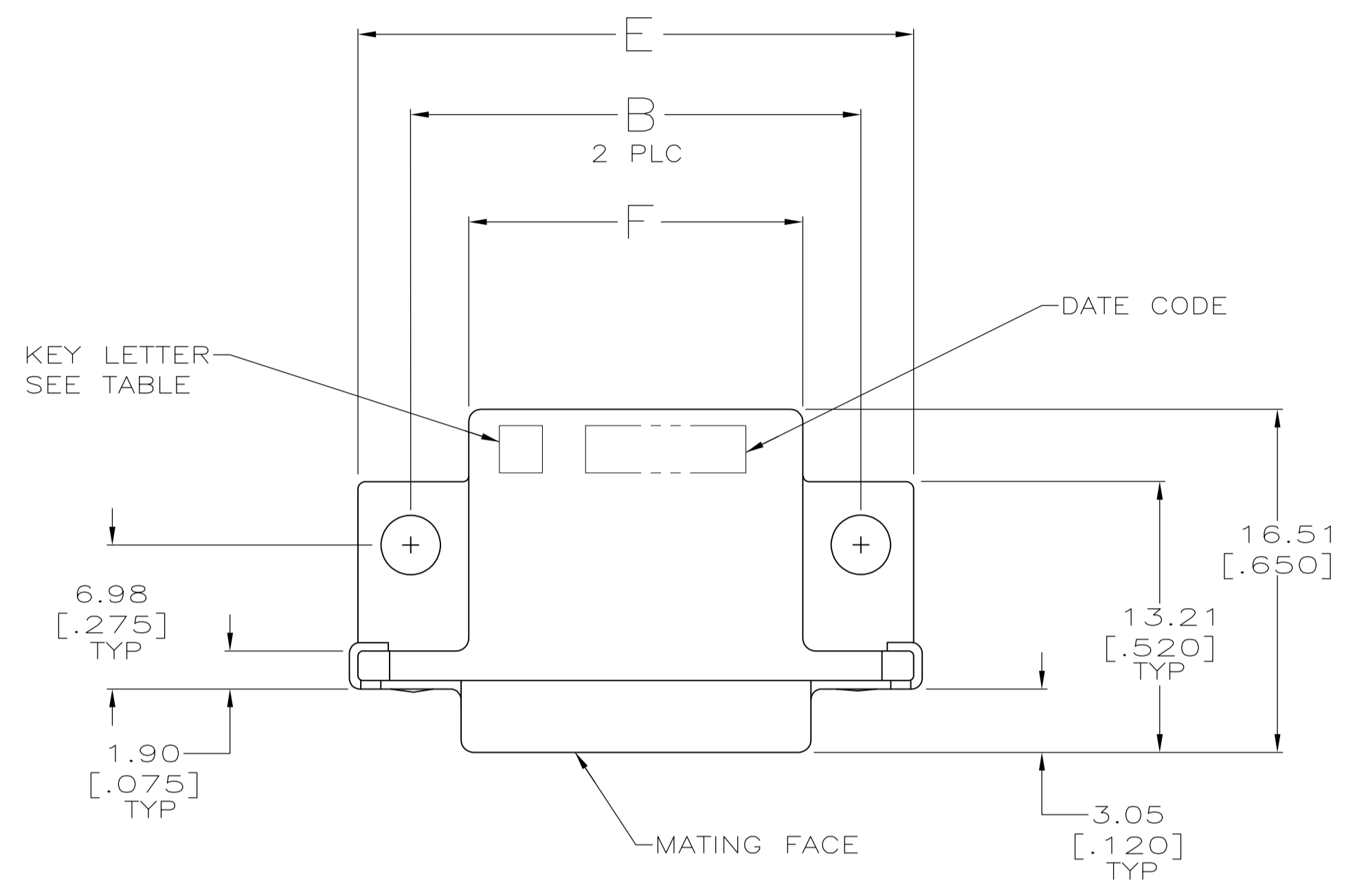
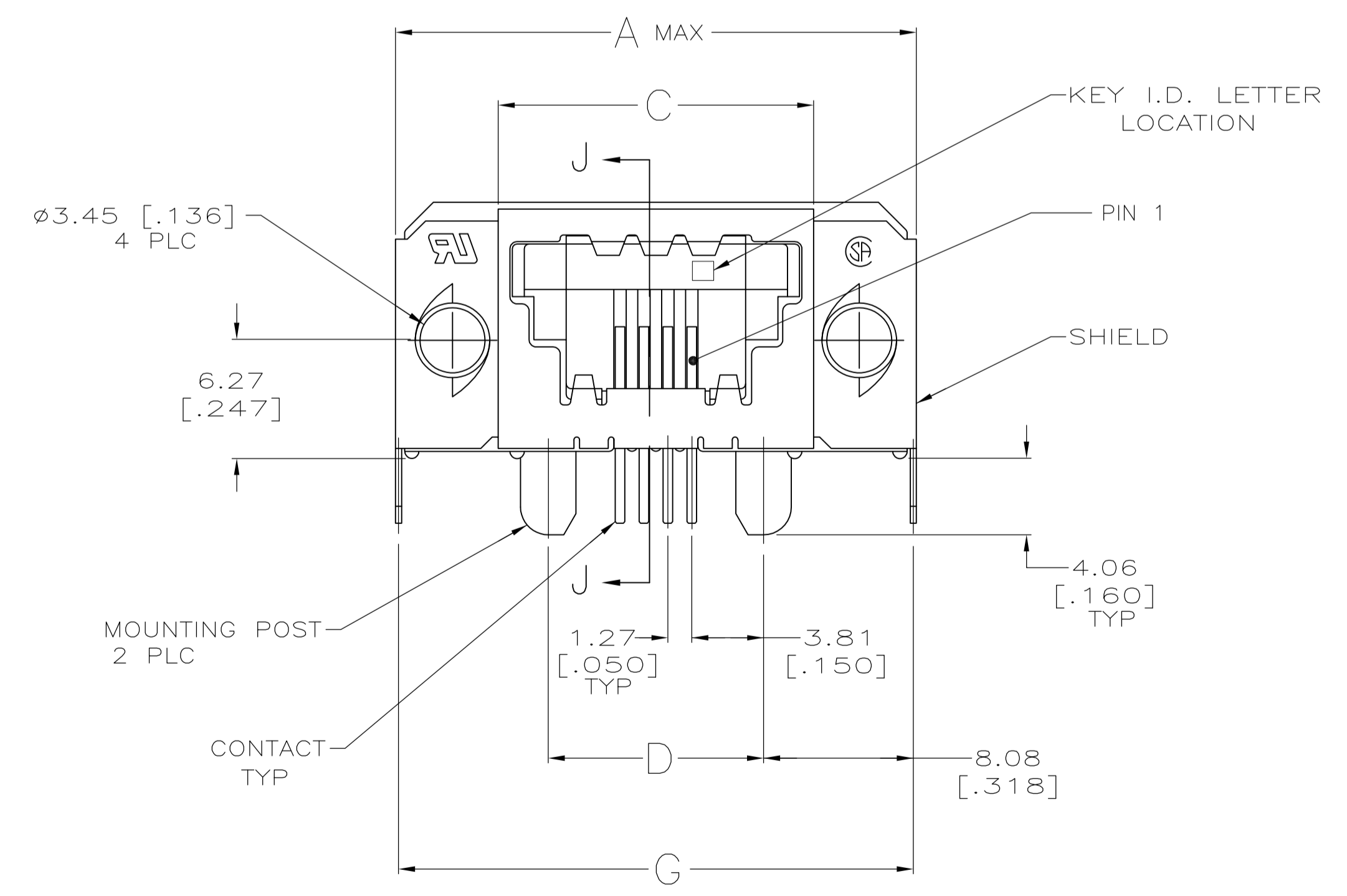

	42.57 [1.676]	31.24 [1.230]	41.91 [1.650]	26.67 [1.050]	31.98 [1.259]	36.83 [1.450]	43.18 [1.700]	16	E	5-1761185-6
	32.41 [1.276]	21.08 [.830]	31.75 [1.250]	16.51 [.650]	21.82 [.859]	26.67 [1.050]	33.02 [1.300]	8	E	5-1761185-3
OBSOLETE	29.87 [1.176]	18.54 [.730]	29.21 [1.150]	13.97 [.550]	19.28 [.759]	24.13 [.950]	30.48 [1.200]	6	E	5-1761185-2
	27.33 [1.076]	16.00 [.630]	26.67 [1.050]	11.43 [.450]	16.74 [.659]	21.59 [.850]	27.94 [1.100]	4	E	5-1761185-1
	27.33 [1.076]	16.00 [.630]	26.67 [1.050]	11.43 [.450]	16.74 [.659]	21.59 [.850]	27.94 [1.100]	4	D	4-1761185-1
	32.41 [1.276]	21.08 [.830]	31.75 [1.250]	16.51 [.650]	21.82 [.859]	26.67 [1.050]	33.02 [1.300]	8	C	3-1761185-3
OBSOLETE	42.57 [1.676]	31.24 [1.230]	41.91 [1.650]	26.67 [1.050]	31.98 [1.259]	36.83 [1.450]	43.18 [1.700]	16	A	1-1761185-6
	32.41 [1.276]	21.08 [.830]	31.75 [1.250]	16.51 [.650]	21.82 [.859]	26.67 [1.050]	33.02 [1.300]	8	A	1-1761185-3
	29.87 [1.176]	18.54 [.730]	29.21 [1.150]	13.97 [.550]	19.28 [.759]	24.13 [.950]	30.48 [1.200]	6	A	1-1761185-2
	27.33 [1.076]	16.00 [.630]	26.67 [1.050]	11.43 [.450]	16.74 [.659]	21.59 [.850]	27.94 [1.100]	4	A	1-1761185-1
G	F	E	D	C	B	A	NO OF POSN	KEY I.D. LETTER	PART NO	

THIS DRAWING IS A CONTROLLED DOCUMENT.

DIMENSIONS: mm [INCHES]

TOLERANCES UNLESS OTHERWISE SPECIFIED:

0 PLC	± .01
1 PLC	± .01
2 PLC	± .01
3 PLC	± .01
4 PLC	± .01
ANGLES	± .01

MATERIAL: FINISH:

APPROVED: M. WALMSLEY

DATE: 26APR04

NAME: RECEPTACLE ASSEMBLY, SIDE ENTRY WITH GROUND, SDL

SIZE: A1

SCALE: 4:1

SHEET: 1 of 1

REV: C