

LOC	DIST	P	F	REVISIONS		
ZONE	LTR	DESCRIPTION	DATE	APPD		
AJ	16			D	REVISED PER 0220-0219-96	5-22-96 JG

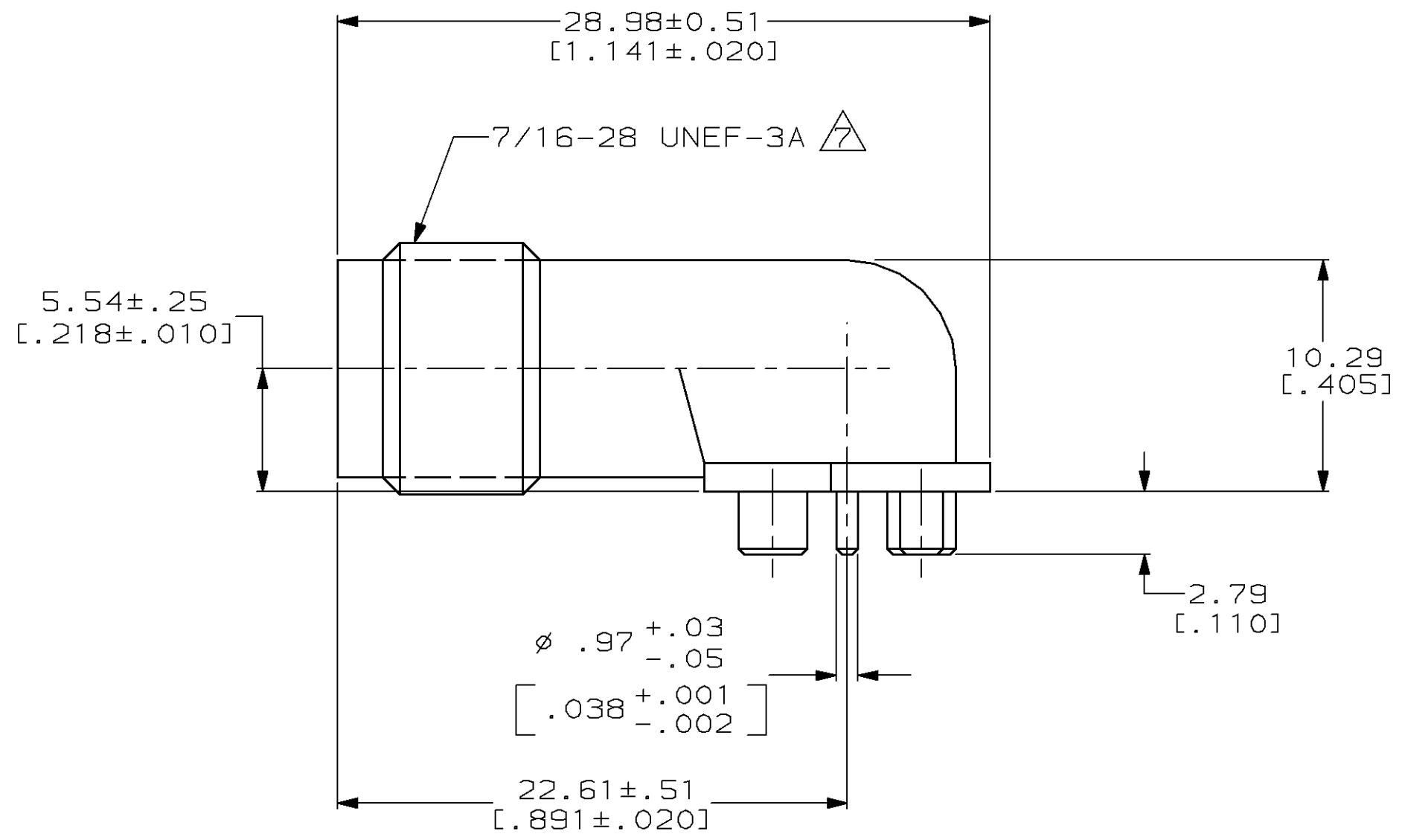

- 1 ZINC PER QQ-Z-363
- 2 BERYLLIUM COPPER PER QQ-C-530
- 3 PTFE PER MIL-P-19468
- 4 NICKEL PLATE PER QQ-N-290, .0051 [.000200] MINIMUM THICKNESS
- 5 GOLD PLATE PER MIL-G-45204 .0013 [.000050] MINIMUM THICKNESS
- 6. INTERMATEABLE WITH PRODUCT PER MIL-C-39012
- 7 MAJOR THREAD DIAMETER TO BE .437/.427, DIMENSION TO BE MEASURED 90° OPPOSITE THE PARTING LINE.
- 8 POLYMETHYLPENTENE, GENERAL PURPOSE

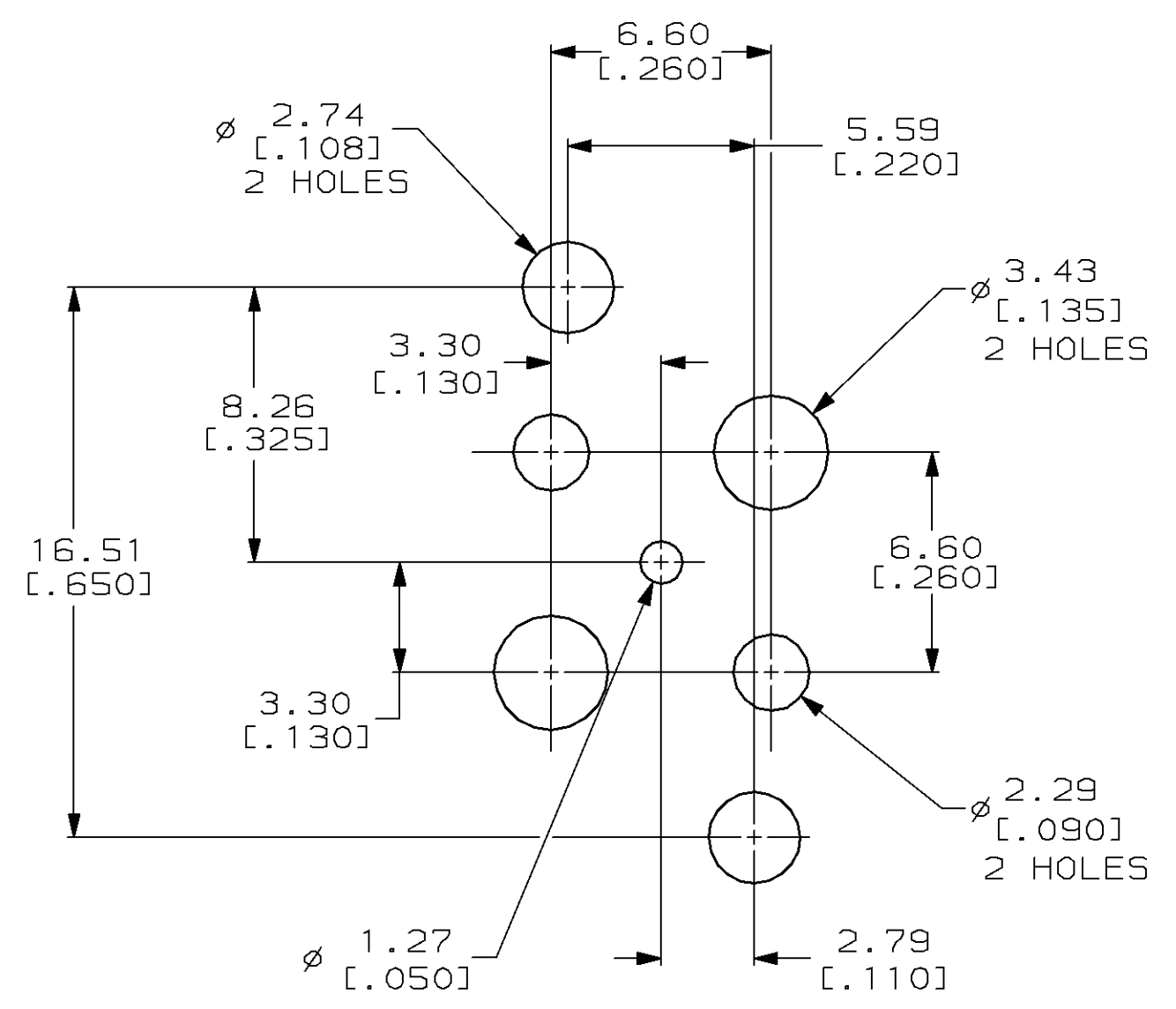
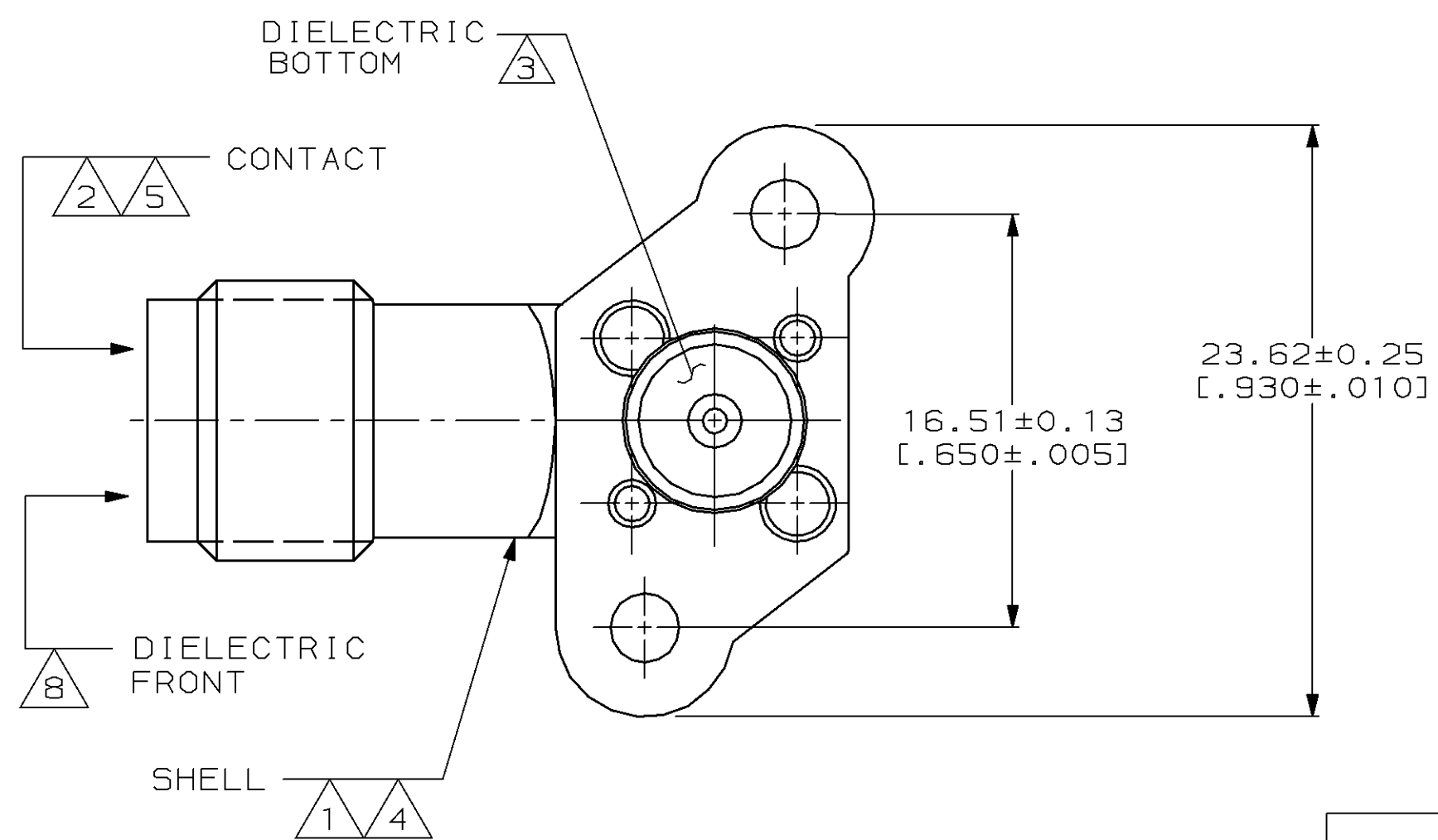

413933-1
PART NUMBER

DO NOT SCALE PRINT. UNLESS SPECIFIED DIMENSIONS IN mm [INCHES] TOLERANCES ON : 2 PLC DEC ± 0.08 [.003] 3 PLC DEC ± - ANGLES ± -		DR 8-21-90 B. WERNER		AMP Incorporated Harrisburg, PA 17105-3608	
MATERIAL		CHK 9-4-90 R.E.RUTH			
FINISH		APPD 9-4-90 R. HENRY		NAME	
		APPD 9-4-90 B. WERNER		JACK, RIGHT ANGLE, PCB, 50 OHM, SERIES TNC	
		PRODUCT SPEC		SIZE	
		APPLICATION SPEC		CAGE CODE	
		WEIGHT -		00779	
				DRAWING NO	
				413933	
				SCALE 4:1	
				SHEET 1 OF 1	