

## DLPC200 DLP Digital Controller for the DLP5500 DMD

### 1 Features

- Required for Reliable Operation of the DLP5500 DMD
- Stream Data Realtime With Two 24-Bit Input Ports (RGB888)
  - Port 1 Supports HDMI Input
  - Port 2 Supports Input Via an Expansion Card
- High-Speed Pattern Sequence Mode
  - Download Pattern Data Directly to Device
  - 1-Bit Binary Pattern Rates to 5000 Hz
  - 8-Bit Grayscale Pattern Rates to 700 Hz
  - 1-to-1 Input Mapping to Micromirrors
  - Programmable Reordering of Patterns
- Easy Synchronization With Cameras and Sensors
  - Three Configurable Output Triggers
  - Two Configurable Input Triggers
- Multiple Configuration Interfaces
  - Supports EDID Via I<sup>2</sup>C
  - USB and SPI Device Control

### 2 Applications

- Industrial
  - 3D Machine Vision and Quality Control
  - 3D Imaging Microscopes
  - 3D Printers
- Medical
  - Ophthalmology
  - 3D Scanners
  - Vascular Imaging

### 3 Description

The DLPC200 performs image processing and control and DMD data formatting to drive the 0.55 XGA DMD (DLP5500).

This digital controller gives users reliable, independent high-speed micromirror control. It is used for structured light, display, and other spatial light modulation (SLM) applications. Solid state illumination (SSI) technology provides pattern rates up to 5000 Hz binary or 700 Hz 8-bit grayscale.

This easily-programmable device allows users to interface and synchronize the chipset to external sources (for example, sensor, camera, and processor) enabling 3D machine vision applications with high accuracy. Multiple configuration interfaces offer flexibility for external and embedded input sources. Because the DLPC200 conveniently loads and stores custom patterns it is ideal for advanced light control applications.

#### Device Information<sup>(1)</sup>

PART NUMBER	PACKAGE	BODY SIZE (NOM)
DLPC200	BGA (780)	29.00 mm x 29.00 mm

(1) For all available packages, see the orderable addendum at the end of the data sheet.

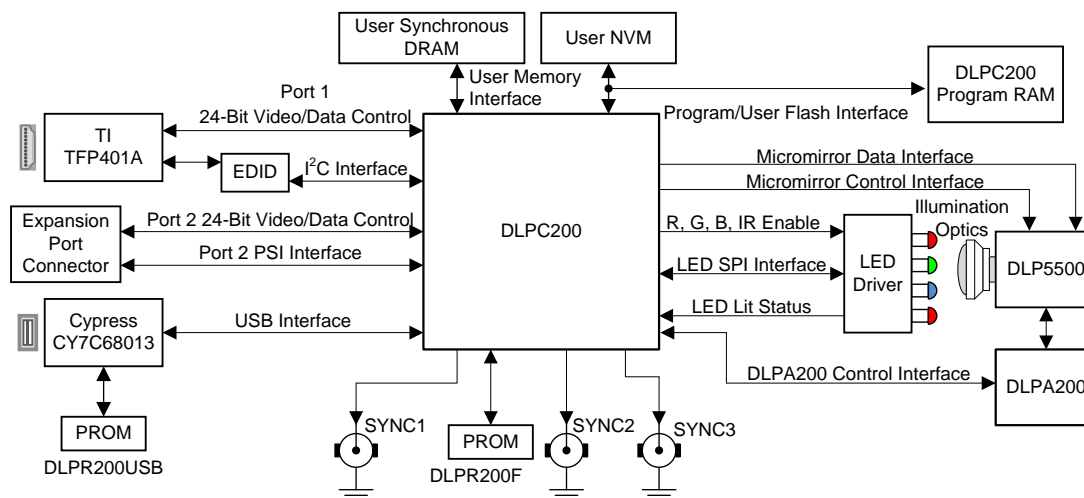

## Table of Contents

<b>1 Features</b> .....	<b>1</b>	<b>7 Detailed Description</b> .....	<b>35</b>
<b>2 Applications</b> .....	<b>1</b>	7.1 Overview .....	35
<b>3 Description</b> .....	<b>1</b>	7.2 Functional Block Diagram .....	35
<b>4 Revision History</b> .....	<b>2</b>	7.3 Feature Description .....	35
<b>5 Pin Configuration and Functions</b> .....	<b>5</b>	7.4 Device Functional Modes .....	36
<b>6 Specifications</b> .....	<b>20</b>	<b>8 Application and Implementation</b> .....	<b>37</b>
6.1 Absolute Maximum Ratings .....	20	8.1 Application Information .....	37
6.2 Handling Ratings .....	20	8.2 Typical Application .....	37
6.3 Recommended Operating Conditions .....	20	<b>9 Power Supply Recommendations</b> .....	<b>45</b>
6.4 Thermal Information .....	20	9.1 Power-Up Requirements .....	45
6.5 I/O Electrical Characteristics .....	21	9.2 Power-Down Requirements .....	45
6.6 Video Input Pixel Interface Timing Requirements .....	21	<b>10 Layout</b> .....	<b>46</b>
6.7 I <sup>2</sup> C Interface Timing Requirements .....	23	10.1 Layout Guidelines .....	46
6.8 USB Read Interface Timing Requirements .....	25	10.2 Layout Example .....	46
6.9 USB Write Interface Timing Requirements .....	26	10.3 Thermal Considerations .....	47
6.10 SPI Slave Interface Timing Requirements .....	27	<b>11 Device and Documentation Support</b> .....	<b>48</b>
6.11 Parallel Flash Interface Timing Requirements .....	28	11.1 Device Support .....	48
6.12 Serial Flash Interface Timing Requirements .....	30	11.2 Documentation Support .....	48
6.13 Static RAM Interface Timing Requirements .....	31	11.3 Receiving Notification of Documentation Updates .....	48
6.14 DMD Interface Timing Requirements .....	31	11.4 Community Resources .....	49
6.15 DLPA200 Interface Timing Requirements .....	32	11.5 Trademarks .....	49
6.16 DDR2 SDR Memory Interface Timing Requirements .....	33	11.6 Electrostatic Discharge Caution .....	49
6.17 Video Input Pixel Interface – Image Sync and Blanking Requirements .....	34	11.7 Glossary .....	49
		<b>12 Mechanical, Packaging, and Orderable Information</b> .....	<b>49</b>

## 4 Revision History

NOTE: Page numbers for previous revisions may differ from page numbers in the current version.

<b>Changes from Revision E (August 2014) to Revision F</b>	<b>Page</b>
• Updated system diagram .....	1
• Added "(does not tristate)" to pin function entry SLAVE_SPI_MISO .....	8
• Deleted the active low indicator in the SLAVE_SPI_ACK in <a href="#">SPI Slave Interface Timing Requirements</a> .....	27
• Changed SPI Timing Figure to reflect that the SLAVE_SPI_MISO signal does not tristate .....	27
• Changed SPI Timing Figure to reflect that SLAVE_SPI_ACK is an active high signal .....	27
• Removed active low indicator from the SLAVE_SPI_ACK signal in <a href="#">SPI Slave Interface</a> .....	40
• Added clarifying note on the operation of the SLAVE_SPI_MOSI signal in <a href="#">SPI Slave Interface</a> .....	40
• Changed Numonyx to Micron (formerly Numonyx) .....	41
• Added note regarding requiring separate programming files targeting 64 Mb and 128 Mb serial flash devices .....	41
• Changed 64 Mb Micron (formerly Numonyx) serial flash status to Obsolete .....	41
• Changed 64 Mb Winbond serial flash status to Obsolete .....	41
• Added Micron 128 Mb serial flash .....	41
• Added Macronix 128 Mb serial flash and noted MCU 2.3.1 or greater required .....	41

<b>Changes from Revision D (March 2012) to Revision E</b>	<b>Page</b>
• Added <i>Handling Ratings</i> table, <i>Feature Description</i> section, <i>Device Functional Modes</i> , <i>Application and Implementation</i> section, <i>Power Supply Recommendations</i> section, <i>Layout</i> section, <i>Device and Documentation Support</i> section, and <i>Mechanical, Packaging, and Orderable Information</i> section .....	1
• Updated descriptions in Pin Functions table .....	6

• Added Grounding scheme for Video Port 1 signals if not used .....	6
• Added Grounding scheme for video port 2 signals if not used .....	7
• Added Connection scheme for EDID and USB if not used .....	8
• Added Connection scheme for LED illumination Control if not used .....	15
• Added recommendation for 1-k $\Omega$ pullup to 3.3 V .....	15
• Changed from "recommend grounding" to "recommend 10-k $\Omega$ pulldown to DGND" for RSVD_S1, RSVD_S2, RSVD_S3, RSVD_X11, RSVD_S20, and RSVD_S21 .....	17
• Changed description for RSVD_S0 from "do not connect" to "can be left open, recommend 10-k $\Omega$ pullup to 2.5 V" .....	17
• Changed pin description for RSVD_x15 and RSVD_X13 from "do not connect" to "do not leave open, required: 49.4- $\Omega$ pullup to 1.8 V" .....	17
• Changed pin description for RSVD_X14 and RSVD_X12 from "do not connect" to "do not leave open, required: 49.9- $\Omega$ pulldown to DGND" .....	17
• Changed from "do not connect" to "can be left open, recommend 10-k $\Omega$ pullup to 1.8 V" for RSVD_S4 .....	17
• Changed pin description for RSVD_S18 and RSVD_S19 from "do not connect" to "can be left open, recommend 10-k $\Omega$ pullup to 2.5 V" .....	18
• Deleted Case Temperature thermal resistance .....	20
• Changed Micron MT47H32M16-25E replaces now obsolete MT47H32M16R .....	43
• Added Note about LED enabling after initialization is complete .....	45
• Added Heat Sink section .....	47

**Changes from Revision C (February 2012) to Revision D**
**Page**

• Changed the $\overline{ADV}$ time line in <a href="#">Figure 6</a> .....	28
--	----

**Changes from Revision B (December 2010) to Revision C**
**Page**

• Changed typo on pin number for PORT1_D10 Pin .....	6
• Changed typo on pin number for USB_CLK Pin .....	8
• Changed I/O type to B <sub>2</sub> for USB interface data bus Pins .....	8
• Added pin number A15 to PINFUNCTIONS table .....	8
• Changed I/O type to B <sub>2</sub> for Flash/SRAM data Pins .....	11
• Corrected the I/O type to O <sub>3</sub> on $\overline{CFG\_CS0}$ terminal pin .....	16
• Added pin number AB17, U7, U8, and AD15 to Pin Functions table .....	17
• Changed location of Absolute Maximum Ratings and Recommended Operating Conditions Tables in document .....	20
• Changed MIN and MAX T <sub>J</sub> values in <i>Recommended Operating Conditions</i> .....	20
• Added V <sub>CC33</sub> and V <sub>REF_B2-4</sub> pins to <i>Recommended Operating Conditions</i> .....	20
• Changed Input Port Interface figure .....	22
• Changed SPI <i>Slave Interface Timing Requirements</i> table .....	27
• Added SPI Timing diagram .....	27
• Changed $\overline{RST}$ signal timing in Parallel Flash Write Timing diagram .....	29
• Changed signal notations in <i>Serial Flash Interface Timing Requirements</i> table .....	30
• Changed signal notations in Flash Memory Interface Timing diagram .....	30
• Changed signal notations in DLPA200 I/F Timing diagram .....	32
• Changed Typical Application diagram .....	38
• Changed paragraph about read mode in <i>Parallel Flash Memory Interface</i> .....	41
• Deleted SRAM Interface Timing diagram and provided reference to the OEM data sheet .....	41
• Replaced "DAD" with "DLPA200" .....	43
• Changed location of Device Marking in document .....	48

---

**Changes from Revision A (May 2010) to Revision B**
**Page**

• Changed typo on pin number for MEM_D43 Pin .....	14
• Changed typo on pin number for MEM_D62 Pin .....	14
• Added part number used for EEPROM .....	40
• Changed part number for Winbond part .....	41
• Added new section for Power-Down Requirements .....	45

---

**Changes from Original (April 2010) to Revision A**
**Page**

• Added / changed pin names, updated descriptions in Pin Functions table .....	6
• Changed junction temperature and notated need for heat sink .....	20
• Deleted unused types, updated values in I/O Characteristics table .....	21
• Changed parameter names to match figure .....	34
• Added new section for Power-Up Requirements .....	45
• Changed TI Lit Number from DLPS012 to DLPZ004 in Related Documents .....	48

---

## 5 Pin Configuration and Functions

**BGA  
780 PINS**

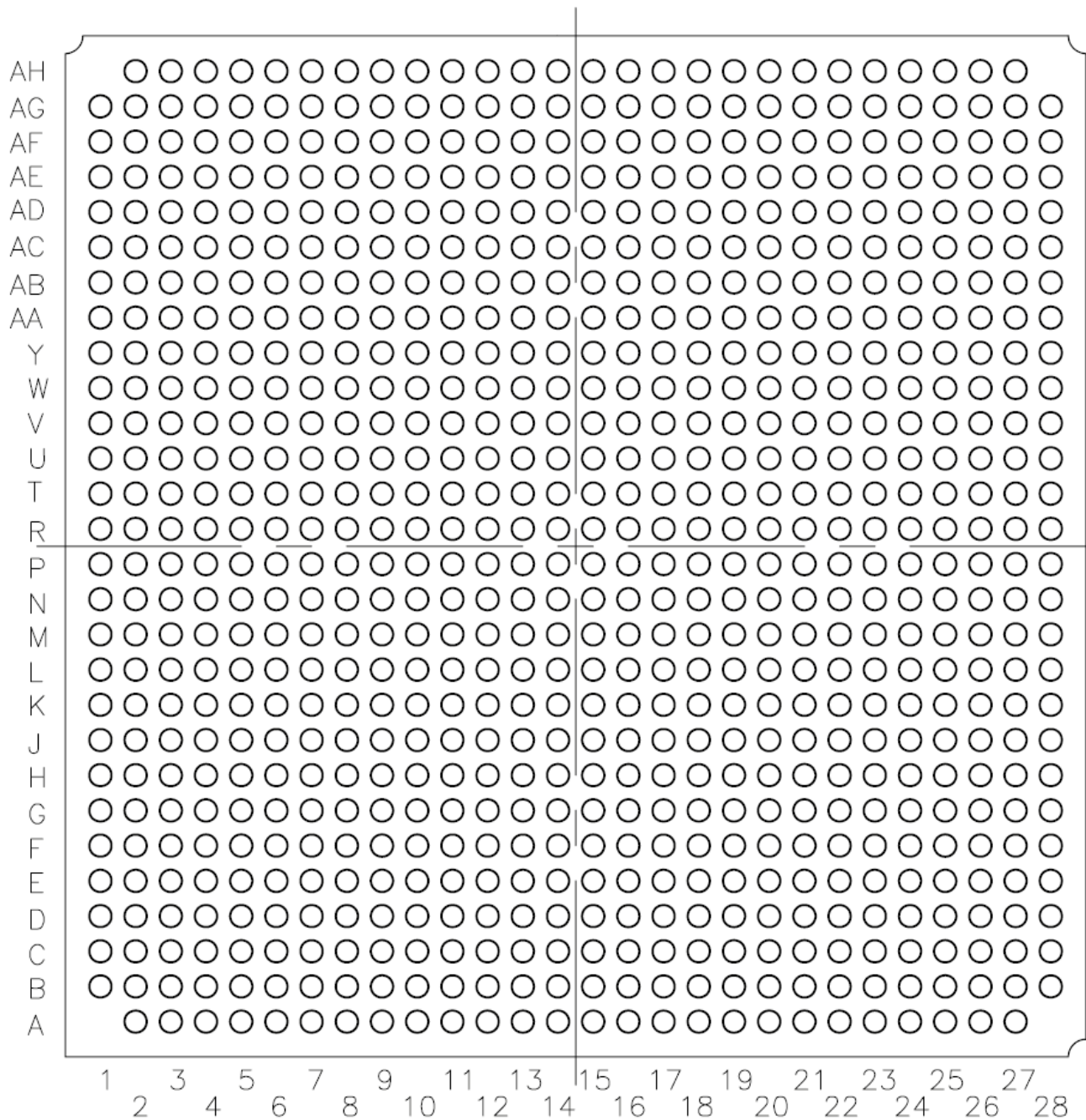

**Pin Functions**

PIN		I/O TYPE <sup>(1)</sup>	CLOCK SYSTEM	DESCRIPTION
NAME	NUMBER			
<b>PORT 1 VIDEO DATA AND CONTROL<sup>(2)</sup></b>				
PORT1_CLK	J2	I <sub>3</sub>		Pixel clock (if not used, apply 10-kΩ pulldown to DGND)
PORT1_VSYNC	N3		PORT1_CLK	Vertical sync; weak pullup applied
PORT1_HSYNC	P1		PORT1_CLK	Horizontal sync; weak pullup applied
PORT1_IVALID	P2		PORT1_CLK	Data valid (if not used, apply 10-kΩ pulldown to DGND)
PORT1_D0	D2		PORT1_CLK	Pixel data – Blue 0 (if not used, apply 10-kΩ pulldown to DGND)
PORT1_D1	D3		PORT1_CLK	Pixel data – Blue 1 (if not used, apply 10-kΩ pulldown to DGND)
PORT1_D2	F5		PORT1_CLK	Pixel data – Blue 2 (if not used, apply 10-kΩ pulldown to DGND)
PORT1_D3	D1		PORT1_CLK	Pixel data – Blue 3 (if not used, apply 10-kΩ pulldown to DGND)
PORT1_D4	F3		PORT1_CLK	Pixel data – Blue 4 (if not used, apply 10-kΩ pulldown to DGND)
PORT1_D5	G4		PORT1_CLK	Pixel data – Blue 5 (if not used, apply 10-kΩ pulldown to DGND)
PORT1_D6	F1		PORT1_CLK	Pixel data – Blue 6 (if not used, apply 10-kΩ pulldown to DGND)
PORT1_D7	G3		PORT1_CLK	Pixel data – Blue 7 (if not used, apply 10-kΩ pulldown to DGND)
PORT1_D8	H5		PORT1_CLK	Pixel data – Green 0 (if not used, apply 10-kΩ pulldown to DGND)
PORT1_D9	H4		PORT1_CLK	Pixel data – Green 1 (if not used, apply 10-kΩ pulldown to DGND)
PORT1_D10	G2		PORT1_CLK	Pixel data – Green 2 (if not used, apply 10-kΩ pulldown to DGND)
PORT1_D11	J4		PORT1_CLK	Pixel data – Green 3 (if not used, apply 10-kΩ pulldown to DGND)
PORT1_D12	H3		PORT1_CLK	Pixel data – Green 4 (if not used, apply 10-kΩ pulldown to DGND)
PORT1_D13	J3		PORT1_CLK	Pixel data – Green 5 (if not used, apply 10-kΩ pulldown to DGND)
PORT1_D14	K3		PORT1_CLK	Pixel data – Green 6 (if not used, apply 10-kΩ pulldown to DGND)
PORT1_D15	L1		PORT1_CLK	Pixel data – Green 7 (if not used, apply 10-kΩ pulldown to DGND)
PORT1_D16	L3		PORT1_CLK	Pixel data – Red 0 (if not used, apply 10-kΩ pulldown to DGND)
PORT1_D17	L4		PORT1_CLK	Pixel data – Red 1 (if not used, apply 10-kΩ pulldown to DGND)
PORT1_D18	M4		PORT1_CLK	Pixel data – Red 2 (if not used, apply 10-kΩ pulldown to DGND)
PORT1_D19	K1	PORT1_CLK	Pixel data – Red 3 (if not used, apply 10-kΩ pulldown to DGND)	
PORT1_D20	M1	PORT1_CLK	Pixel data – Red 4 (if not used, apply 10-kΩ pulldown to DGND)	
PORT1_D21	K2	PORT1_CLK	Pixel data – Red 5 (if not used, apply 10-kΩ pulldown to DGND)	
PORT1_D22	M2	PORT1_CLK	Pixel data – Red 6 (if not used, apply 10-kΩ pulldown to DGND)	
PORT1_D23	M3	PORT1_CLK	Pixel data – Red 7 (if not used, apply 10-kΩ pulldown to DGND)	
PORT1_HPD	E15	B <sub>2</sub>		HDMI hotplug detect, (if not used, apply 10-kΩ pulldown to DGND)
PORT1_SYNCDET	J22			HDMI input sync detect, (if not used, apply 10-kΩ pulldown to DGND)

(1) See [I/O Electrical Characteristics](#) for more detail.

(2) 24-bit data is mapped according to RGB888 pixel format. See [Figure 13](#).

**Pin Functions (continued)**

PIN		I/O TYPE <sup>(1)</sup>	CLOCK SYSTEM	DESCRIPTION
NAME	NUMBER			
<b>PORT 2 VIDEO DATA AND CONTROL<sup>(2)</sup></b>				
PORT2_CLK	Y2	I <sub>1</sub>		Pixel clock (if not used, apply 10-kΩ pulldown to DGND)
PORT2_VSYNC	AF2		PORT2_CLK	Vertical sync; weak pullup applied
PORT2_HSYNC	AB6		PORT2_CLK	Horizontal sync; weak pullup applied
PORT2_IVALID	W1		PORT2_CLK	Data valid (if not used, apply 10-kΩ pulldown to DGND)
PORT2_D0	Y1		PORT2_CLK	Pixel data – Blue 0 (if not used, apply 10-kΩ pulldown to DGND)
PORT2_D1	AE1		PORT2_CLK	Pixel data – Blue 1 (if not used, apply 10-kΩ pulldown to DGND)
PORT2_D2	U2		PORT2_CLK	Pixel data – Blue 2 (if not used, apply 10-kΩ pulldown to DGND)
PORT2_D3	AD12		PORT2_CLK	Pixel data – Blue 3 (if not used, apply 10-kΩ pulldown to DGND)
PORT2_D4	AB1		PORT2_CLK	Pixel data – Blue 4 (if not used, apply 10-kΩ pulldown to DGND)
PORT2_D5	V3		PORT2_CLK	Pixel data – Blue 5 (if not used, apply 10-kΩ pulldown to DGND)
PORT2_D6	U5		PORT2_CLK	Pixel data – Blue 6 (if not used, apply 10-kΩ pulldown to DGND)
PORT2_D7	T3		PORT2_CLK	Pixel data – Blue 7 (if not used, apply 10-kΩ pulldown to DGND)
PORT2_D8	AD1		PORT2_CLK	Pixel data – Green 0 (if not used, apply 10-kΩ pulldown to DGND)
PORT2_D9	AA3		PORT2_CLK	Pixel data – Green 1 (if not used, apply 10-kΩ pulldown to DGND)
PORT2_D10	R6		PORT2_CLK	Pixel data – Green 2 (if not used, apply 10-kΩ pulldown to DGND)
PORT2_D11	W3		PORT2_CLK	Pixel data – Green 3 (if not used, apply 10-kΩ pulldown to DGND)
PORT2_D12	AB5		PORT2_CLK	Pixel data – Green 4 (if not used, apply 10-kΩ pulldown to DGND)
PORT2_D13	AD3		PORT2_CLK	Pixel data – Green 5 (if not used, apply 10-kΩ pulldown to DGND)
PORT2_D14	AD5		PORT2_CLK	Pixel data – Green 6 (if not used, apply 10-kΩ pulldown to DGND)
PORT2_D15	AD4		PORT2_CLK	Pixel data – Green 7 (if not used, apply 10-kΩ pulldown to DGND)
PORT2_D16	AE5		PORT2_CLK	Pixel data – Red 0 (if not used, apply 10-kΩ pulldown to DGND)
PORT2_D17	AC11		PORT2_CLK	Pixel data – Red 1 (if not used, apply 10-kΩ pulldown to DGND)
PORT2_D18	AB8		PORT2_CLK	Pixel data – Red 2 (if not used, apply 10-kΩ pulldown to DGND)
PORT2_D19	AC7	PORT2_CLK	Pixel data – Red 3 (if not used, apply 10-kΩ pulldown to DGND)	
PORT2_D20	AG4	PORT2_CLK	Pixel data – Red 4 (if not used, apply 10-kΩ pulldown to DGND)	
PORT2_D21	AE4	PORT2_CLK	Pixel data – Red 5 (if not used, apply 10-kΩ pulldown to DGND)	
PORT2_D22	AF5	PORT2_CLK	Pixel data – Red 6 (if not used, apply 10-kΩ pulldown to DGND)	
PORT2_D23	AF3	PORT2_CLK	Pixel data – Red 7 (if not used, apply 10-kΩ pulldown to DGND)	
<b>SYNC IN/SYNC OUT</b>				
PORT1_Trig_in	F2	I <sub>3</sub>	PORT1_CLK	Alternate sync for port 1; treated as Vsync; weak pullup applied
PORT1_Sync_out	H6	O <sub>3</sub>	Async	Reserved for future use
PORT2_Trig_in	AB7	I <sub>1</sub>	PORT2_CLK	Alternate sync for port 2; treated as vsync; weak pullup applied
PORT2_Sync_out	Y3	O <sub>1</sub>	Async	Reserved for future use

**Pin Functions (continued)**

PIN		I/O TYPE <sup>(1)</sup>	CLOCK SYSTEM	DESCRIPTION
NAME	NUMBER			
<b>CONTROL INTERFACES (I<sup>2</sup>C, USB, SPI)</b>				
USB_CLK	B15	I <sub>3</sub>		USB clock input (48 MHz), feeds a PLL (if not used, apply 10-kΩ pulldown to DGND)
USB_CTRL0	B17	I <sub>3</sub>	USB_CLK	USB I/F FIFO programmable level (if not used, apply 10-kΩ pulldown to DGND)
USB_CTRL1	A26	I <sub>3</sub>	USB_CLK	USB I/F FIFO-full flag (if not used, apply 10-kΩ pulldown to DGND)
USB_CTRL2	D22	I <sub>3</sub>	USB_CLK	USB I/F FIFO-empty flag (if not used, apply 10-kΩ pulldown to DGND)
USB_CTRL3	C19	I <sub>3</sub>	USB_CLK	Reserved for future use (if not used, apply 10-kΩ pulldown to DGND)
USB_CTRL4	D16	I <sub>3</sub>	USB_CLK	Reserved for future use (if not used, apply 10-kΩ pulldown to DGND)
USB_CTRL5	G17	I <sub>3</sub>	USB_CLK	Reserved for future use (if not used, apply 10-kΩ pulldown to DGND)
USB_FD0	G16	B <sub>2</sub>	USB_CLK	USB interface data bus (if not used, apply 10-kΩ pulldown to DGND)
USB_FD1	C26			
USB_FD2	F17			
USB_FD3	C22			
USB_FD4	E18			
USB_FD5	B18			
USB_FD6	F18			
USB_FD7	E19			
USB_FD8	B23			
USB_FD9	D25			
USB_FD10	C21			
USB_FD11	D24			
USB_FD12	B19			
USB_FD13	E25			
USB_FD14	G18			
USB_FD15	C15			
USB_PA02	D23	O <sub>3</sub>	USB_CLK	USB I/F FIFO output enable for reads (if not used, apply 10-kΩ pullup to 3.3 V)
USB_PA04	G15	O <sub>3</sub>	USB_CLK	USB I/F FIFO address(0) (if not used, apply 10-kΩ pullup to 3.3 V)
USB_PA05	A22	O <sub>3</sub>	USB_CLK	USB I/F FIFO address(1) (if not used, apply 10-kΩ pullup to 3.3 V)
USB_PA06	A25	O <sub>3</sub>	USB_CLK	USB I/F FIFO packet end trigger
USB_RDY0	C16	O <sub>3</sub>	USB_CLK	USB I/F FIFO read enable (if not used, apply 10-kΩ pullup to 3.3 V)
USB_RDY1	C17	O <sub>3</sub>	USB_CLK	USB I/F FIFO write enable (if not used, apply 10-kΩ pullup to 3.3 V)
USB_RDY2	B26	O <sub>3</sub>	USB_CLK	Reserved for future use (if not used, apply 10-kΩ pullup to 3.3 V)
USB_RSVD_14	A15	I <sub>3</sub>	USB_CLK	Reserved for future use (if not used, apply 10-kΩ pulldown to DGND)
I2C_SCL	C25	B <sub>2</sub>		Master I <sup>2</sup> C clock - 400 kHz. Requires external pullup
I2C_SDA	D18	B <sub>2</sub>	I2C_SCL	Master I <sup>2</sup> C data - 400 kHz. Requires external pullup
EDID_I2C_SCL	F8	B <sub>2</sub>		HDMI EDID I <sup>2</sup> C clock. 400 kHz. Requires external pullup (if EDID is not used, must be pulled up to 3.3 V through a 47-kΩ resistor)
EDID_I2C_SDA	D6	B <sub>2</sub>	EDID_I2C_SCL	HDMI EDID I <sup>2</sup> C data. 400-kHz. Requires external pullup (if EDID is not used, must be pulled up to 3.3 V through a 47-kΩ resistor.)
SLAVE_SPI_CLK	B14	I <sub>3</sub>		Slave SPI clock
SLAVE_SPI_CS	C14	I <sub>3</sub>	SLAVE_SPI_CLK	Slave SPI chip select; weak pullup applied
SLAVE_SPI_MISO	D14	O <sub>3</sub>	SLAVE_SPI_CLK	Slave SPI data OUT (does not tristate)
SLAVE_SPI_MOSI	E14	I <sub>3</sub>	SLAVE_SPI_CLK	Slave SPI data IN; weak pullup applied
SLAVE_SPI_SOP	F21	I <sub>3</sub>	SLAVE_SPI_CLK	Reserved for future use
SLAVE_SPI_ACK	D20	O <sub>3</sub>	SLAVE_SPI_CLK	Slave SPI data busy



**Pin Functions (continued)**

PIN		I/O TYPE <sup>(1)</sup>	CLOCK SYSTEM	DESCRIPTION
NAME	NUMBER			
<b>DMD INTERFACE</b>				
DMD_DAT_AP1	AB27	O <sub>4</sub>	DMD_DCLK_AP, DMD_DCLK_AN	DMD data pins. LVDS pins for data bus A
DMD_DAT_AN1	AB28	O <sub>4</sub>		
DMD_DAT_AP3	Y25	O <sub>4</sub>		
DMD_DAT_AN3	Y26	O <sub>4</sub>		
DMD_DAT_AP5	W25	O <sub>4</sub>		
DMD_DAT_AN5	W26	O <sub>4</sub>		
DMD_DAT_AP7	W28	O <sub>4</sub>		
DMD_DAT_AN7	W27	O <sub>4</sub>		
DMD_DAT_AP9	V27	O <sub>4</sub>		
DMD_DAT_AN9	V28	O <sub>4</sub>		
DMD_DAT_AP11	V25	O <sub>4</sub>		
DMD_DAT_AN11	V26	O <sub>4</sub>		
DMD_DAT_AP13	V23	O <sub>4</sub>		
DMD_DAT_AN13	V24	O <sub>4</sub>		
DMD_DAT_AP15	T26	O <sub>4</sub>		
DMD_DAT_AN15	U27	O <sub>4</sub>		
DMD_DCLK_AP	T25	O <sub>4</sub>		DMD data clock. LVDS clock for data bus A
DMD_DCLK_AN	U28	O <sub>4</sub>		DMD data clock. LVDS clock for data bus A
DMD_SCTRL_AP	R25	O <sub>4</sub>	DMD_DCLK_AP, DMD_DCLK_AN	DMD data serial-control signal bus A (LVDS)
DMD_SCTRL_AN	R26	O		
DMD_DAT_BP1	AC24	O <sub>4</sub>	DMD_DCLK_BP, DMD_DCLK_BN	DMD data pins. LVDS pins for data bus B
DMD_DAT_BN1	AC25	O <sub>4</sub>		
DMD_DAT_BP3	AC26	O <sub>4</sub>		
DMD_DAT_BN3	AD26	O <sub>4</sub>		
DMD_DAT_BP5	AE27	O <sub>4</sub>		
DMD_DAT_BN5	AE28	O <sub>4</sub>		
DMD_DAT_BP7	AD27	O <sub>4</sub>		
DMD_DAT_BN7	AD28	O <sub>4</sub>		
DMD_DAT_BP9	Y23	O <sub>4</sub>		
DMD_DAT_BN9	Y24	O <sub>4</sub>		
DMD_DAT_BP11	AC27	O <sub>4</sub>		
DMD_DAT_BN11	AC28	O <sub>4</sub>		
DMD_DAT_BP13	AB25	O <sub>4</sub>		
DMD_DAT_BN13	AB26	O <sub>4</sub>		
DMD_DAT_BP15	AA25	O <sub>4</sub>		
DMD_DAT_BN15	AA26	O <sub>4</sub>		
DMD_DCLK_BP	U25	O <sub>4</sub>		DMD data clock. LVDS clock for data bus B
DMD_DCLK_BN	U26	O <sub>4</sub>		DMD data clock. LVDS clock for data bus B
DMD_SCTRL_BP	T21	O <sub>4</sub>	DMD_DCLK_AP, DMD_DCLK_AN	DMD data serial-control signal bus B (LVDS)
DMD_SCTRL_BN	T22	O <sub>4</sub>		
DMD_PWRDN	P26	O <sub>3</sub>	ASYNC	DMD power down (active-low)
RST_IRQ	M25	I <sub>3</sub>	ASYNC	DLPA200 interrupt (active-low)
RST_OE	M28	O <sub>3</sub>	ASYNC	DLPA200 output enable
RST_RST	H24	O <sub>3</sub>	ASYNC	DLPA200 reset
RST_STROBE	G28	O <sub>3</sub>		DLPA200 strobe

**Pin Functions (continued)**

PIN		I/O TYPE <sup>(1)</sup>	CLOCK SYSTEM	DESCRIPTION
NAME	NUMBER			
<b>DMD INTERFACE (CONTINUED)</b>				
RST_SEL0	G27	O <sub>3</sub>	RST_STROBE	DLPA200 voltage select
RST_SEL1	G26			
RST_MODE0	L24	O <sub>3</sub>	RST_STROBE	DLPA200 mode select
RST_MODE1	L23			
RST_A0	K25	O <sub>3</sub>	RST_STROBE	DLPA200 address
RST_A1	J26			
RST_A2	J25			
RST_A3	K26			
SCP_DMD_RST_DO	G25	O <sub>3</sub>	SCP_DMD_RST_CLK	SCP data out (write data)
SCP_DMD_RST_DI	H26	I <sub>3</sub>	SCP_DMD_RST_CLK	SCP data in (read data)
$\overline{\text{SCP\_DMD\_EN}}$	L25	O <sub>3</sub>	SCP_DMD_RST_CLK	DMD SCP chip select
$\overline{\text{SCP\_RST\_EN}}$	H23	O <sub>3</sub>	SCP_DMD_RST_CLK	DLPA200 SCP chip select
SCP_DMD_RST_CLK	H25	O <sub>3</sub>		DMD/DLPA200 SCP clock, 125 kHz
<b>STATIC RAM INTERFACE</b>				
$\overline{\text{FLASH\_CE}}$	D12	O <sub>3</sub>	ASYNC	Flash chip enable
FLASH_SRAM_A0	D13	O <sub>3</sub>	$\overline{\text{FLASH\_SRAM\_WE}}$	Flash/SRAM address
FLASH_SRAM_A1	A11			
FLASH_SRAM_A2	C11			
FLASH_SRAM_A3	D11			
FLASH_SRAM_A4	A12			
FLASH_SRAM_A5	B12			
FLASH_SRAM_A6	D10			
FLASH_SRAM_A7	A10			
FLASH_SRAM_A8	B10			
FLASH_SRAM_A9	B8			
FLASH_SRAM_A10	C8			
FLASH_SRAM_A11	A7			
FLASH_SRAM_A12	B7			
FLASH_SRAM_A13	A4			
FLASH_SRAM_A14	D7			
FLASH_SRAM_A15	C6			
FLASH_SRAM_A16	D8			
FLASH_SRAM_A17	B6			
FLASH_SRAM_A18	C7			
FLASH_SRAM_A19	A8			
FLASH_SRAM_A20	C4			
FLASH_SRAM_A21	B3			
FLASH_SRAM_A22	A3			
FLASH_SRAM_A23	C5			
FLASH_SRAM_A24	D5			
FLASH_SRAM_A25	B4			
FLASH_SRAM_A26	D4			

**Pin Functions (continued)**

PIN		I/O TYPE <sup>(1)</sup>	CLOCK SYSTEM	DESCRIPTION
NAME	NUMBER			
<b>STATIC RAM INTERFACE (CONTINUED)</b>				
FLASH_SRAM_D0	E11	B <sub>2</sub>	$\overline{\text{FLASH\_SRAM\_WE}}$	Flash/SRAM data
FLASH_SRAM_D1	F10			
FLASH_SRAM_D2	E10			
FLASH_SRAM_D3	G9			
FLASH_SRAM_D4	E8			
FLASH_SRAM_D5	E7			
FLASH_SRAM_D6	E5			
FLASH_SRAM_D7	E4			
FLASH_SRAM_D8	F11			
FLASH_SRAM_D9	E12			
FLASH_SRAM_D10	F12			
FLASH_SRAM_D11	G12			
FLASH_SRAM_D12	G13			
FLASH_SRAM_D13	H13			
FLASH_SRAM_D14	F14			
FLASH_SRAM_D15	G14			
$\overline{\text{FLASH\_SRAM\_OE}}$	C10	O <sub>3</sub>		Flash output enable
FLASH_SRAM_RDY	C13	I <sub>3</sub>		Flash wait
$\overline{\text{FLASH\_SRAM\_RST}}$	C12	O <sub>3</sub>		Flash reset
$\overline{\text{FLASH\_SRAM\_WE}}$	A6	O <sub>3</sub>		Flash write enable
$\overline{\text{SRAM\_CE}}$	B11	O <sub>3</sub>		SRAM chip enable
$\overline{\text{SRAM\_LB}}$	D9	O <sub>3</sub>		SRAM lower byte enable
$\overline{\text{SRAM\_UB}}$	C9	O <sub>3</sub>		SRAM upper byte enable
<b>SDRAM INTERFACE</b>				
MEM_CLK_P0	R2	O <sub>5</sub>		DDR2 memory, differential memory clock
MEM_CLK_N0	R1	O <sub>5</sub>		DDR2 memory, differential memory clock
MEM_CLK_P1	U3	O <sub>5</sub>		DDR2 memory, differential memory clock
MEM_CLK_N1	U4	O <sub>5</sub>		DDR2 memory, differential memory clock
MEM_CLK_P2	AC5	O <sub>5</sub>		DDR2 memory, differential memory clock
MEM_CLK_N2	AC4	O <sub>5</sub>		DDR2 memory, differential memory clock
MEM_CLK_P3	AE14	O <sub>5</sub>		DDR2 memory, differential memory clock
MEM_CLK_N3	AF14	O <sub>5</sub>		DDR2 memory, differential memory clock
MEM_CKE0	AF12	O <sub>5</sub>		
MEM_BA0	Y19	O <sub>5</sub>	MEM_CLK	
MEM_BA1	AD21	O <sub>5</sub>	MEM_CLK	
MEM_BA2	AE7	O <sub>5</sub>	MEM_CLK	

**Pin Functions (continued)**

PIN		I/O TYPE <sup>(1)</sup>	CLOCK SYSTEM	DESCRIPTION
NAME	NUMBER			
<b>SDRAM INTERFACE (CONTINUED)</b>				
MEM_A0	AD24	O <sub>5</sub>	MEM_CLK	DDR2 memory, multiplexed row and column address. The memory in the kit is 512 Mb in ×16 mode, 8 Meg × 16 bits × 4 banks. Only A(12:0) and BA(1:0) are currently used. A(15:13) and BA(2) are reserved for future use (RFU).
MEM_A1	AF21			
MEM_A2	AG23			
MEM_A3	AE8			
MEM_A4	AG12			
MEM_A5	AF23			
MEM_A6	AC17			
MEM_A7	AA16			
MEM_A8	AE23			
MEM_A9	AE22			
MEM_A10	AE16			
MEM_A11	AD25			
MEM_A12	AF19			
MEM_A13	AH10			
MEM_A14	AA8			
MEM_A15	AD11			
MEM_CAS	AG19	O <sub>5</sub>	MEM_CLK	Column address strobe, active low
MEM_RAS	AE20	O <sub>5</sub>	MEM_CLK	Row address strobe, active low
MEM_CS0	AF13	O <sub>5</sub>	MEM_CLK	Chip select, active low
MEM_WE	AG25	O <sub>5</sub>	MEM_CLK	Write enable, active low
MEM_ODT	AH12	O <sub>5</sub>	MEM_CLK	
MEM_DM0	W2	O <sub>5</sub>	MEM_CLK	
MEM_DM1	AE2	O <sub>5</sub>	MEM_CLK	
MEM_DM2	AH6	O <sub>5</sub>	MEM_CLK	
MEM_DM3	AF7	O <sub>5</sub>	MEM_CLK	
MEM_DM4	AE13	O <sub>5</sub>	MEM_CLK	
MEM_DM5	AH18	O <sub>5</sub>	MEM_CLK	
MEM_DM6	AF24	O <sub>5</sub>	MEM_CLK	
MEM_DM7	AG26	O <sub>5</sub>	MEM_CLK	
MEM_DS0	AB2	B <sub>1</sub>	MEM_CLK_P0	
MEM_DS1	AE3	B <sub>1</sub>	MEM_CLK_N0	
MEM_DS2	AD7	B <sub>1</sub>	MEM_CLK_P1	
MEM_DS3	AE10	B <sub>1</sub>	MEM_CLK_N1	
MEM_DS4	AF11	B <sub>1</sub>	MEM_CLK_P2	
MEM_DS5	AF17	B <sub>1</sub>	MEM_CLK_N2	
MEM_DS6	AE18	B <sub>1</sub>	MEM_CLK_P3	
MEM_DS7	AF26	B <sub>1</sub>	MEM_CLK_N3	

**Pin Functions (continued)**

PIN		I/O TYPE <sup>(1)</sup>	CLOCK SYSTEM	DESCRIPTION
NAME	NUMBER			
<b>SDRAM INTERFACE (CONTINUED)</b>				
MEM_D0	R3	B <sub>1</sub>	MEM_DS0, MEM_DS1	
MEM_D1	R4	B <sub>1</sub>		
MEM_D2	T4	B <sub>1</sub>		
MEM_D3	R5	B <sub>1</sub>		
MEM_D4	U1	B <sub>1</sub>		
MEM_D5	V4	B <sub>1</sub>		
MEM_D6	V2	B <sub>1</sub>		
MEM_D7	V1	B <sub>1</sub>		
MEM_D8	U6	B <sub>1</sub>		
MEM_D9	Y4	B <sub>1</sub>		
MEM_D10	AC2	B <sub>1</sub>		
MEM_D11	AC1	B <sub>1</sub>		
MEM_D12	AC3	B <sub>1</sub>		
MEM_D13	AD2	B <sub>1</sub>		
MEM_D14	AB3	B <sub>1</sub>		
MEM_D15	AA4	B <sub>1</sub>	MEM_DS2, MEM_DS3	
MEM_D16	AE6	B <sub>1</sub>		
MEM_D17	AF4	B <sub>1</sub>		
MEM_D18	AG3	B <sub>1</sub>		
MEM_D19	AH3	B <sub>1</sub>		
MEM_D20	AF6	B <sub>1</sub>		
MEM_D21	AH4	B <sub>1</sub>		
MEM_D22	AD8	B <sub>1</sub>		
MEM_D23	AG6	B <sub>1</sub>		
MEM_D24	AB9	B <sub>1</sub>		
MEM_D25	AD10	B <sub>1</sub>		
MEM_D26	AG7	B <sub>1</sub>		
MEM_D27	AH7	B <sub>1</sub>		
MEM_D28	AC8	B <sub>1</sub>		
MEM_D29	AA10	B <sub>1</sub>		
MEM_D30	AG8	B <sub>1</sub>		
MEM_D31	AH8	B <sub>1</sub>		

**Pin Functions (continued)**

PIN		I/O TYPE <sup>(1)</sup>	CLOCK SYSTEM	DESCRIPTION
NAME	NUMBER			
<b>SDRAM INTERFACE (CONTINUED)</b>				
MEM_D32	AF8	B <sub>1</sub>	MEM_DS4, MEM_DS5	
MEM_D33	AE9	B <sub>1</sub>		
MEM_D34	AF10	B <sub>1</sub>		
MEM_D35	AG10	B <sub>1</sub>		
MEM_D36	AE12	B <sub>1</sub>		
MEM_D37	AE11	B <sub>1</sub>		
MEM_D38	AG11	B <sub>1</sub>		
MEM_D39	AH11	B <sub>1</sub>		
MEM_D40	AC15	B <sub>1</sub>		
MEM_D41	AF15	B <sub>1</sub>		
MEM_D42	AG17	B <sub>1</sub>		
MEM_D43	AH17	B <sub>1</sub>		
MEM_D44	AF16	B <sub>1</sub>		
MEM_D45	AB16	B <sub>1</sub>		
MEM_D46	AE17	B <sub>1</sub>		
MEM_D47	AG18	B <sub>1</sub>		
MEM_D48	AH19	B <sub>1</sub>		MEM_DS6, MEM_DS7
MEM_D49	AD17	B <sub>1</sub>		
MEM_D50	AG21	B <sub>1</sub>		
MEM_D51	AH21	B <sub>1</sub>		
MEM_D52	AG22	B <sub>1</sub>		
MEM_D53	AH22	B <sub>1</sub>		
MEM_D54	AH23	B <sub>1</sub>		
MEM_D55	AE19	B <sub>1</sub>		
MEM_D56	AF25	B <sub>1</sub>		
MEM_D57	AF20	B <sub>1</sub>		
MEM_D58	AD18	B <sub>1</sub>		
MEM_D59	AE21	B <sub>1</sub>		
MEM_D60	AE25	B <sub>1</sub>		
MEM_D61	AH25	B <sub>1</sub>		
MEM_D62	AF22	B <sub>1</sub>		
MEM_D63	AE24	B <sub>1</sub>		

**Pin Functions (continued)**

PIN		I/O TYPE <sup>(1)</sup>	CLOCK SYSTEM	DESCRIPTION
NAME	NUMBER			
<b>LED DRIVER INTERFACE</b>				
PWM0	C27	O <sub>3</sub>	Async	PWM signal used to control the LED current (if not used, apply 10-kΩ pull-down to DGND)
PWM1	D28	O <sub>3</sub>	Async	PWM signal used to control the LED current (if not used, apply 10-kΩ pull-down to DGND)
PWM2	D27	O <sub>3</sub>	Async	PWM signal used to control the LED current (if not used, apply 10-kΩ pull-down to DGND)
PWM3	D26	O <sub>3</sub>	Async	PWM signal used to control the LED current (if not used, apply 10-kΩ pull-down to DGND)
LED_IR_EN	E28	O <sub>3</sub>	Async	IR LED enable strobe. Controlled by programmable DMD sequence timing (active high), (if not used, apply 1-kΩ pull-down to DGND)
LED_RED_EN	F28	O <sub>3</sub>	Async	RED LED enable strobe. Controlled by programmable DMD sequence timing (active high), (if not used, apply 1-kΩ pull-down to DGND)
LED_GRN_EN	E27	O <sub>3</sub>	Async	Green LED enable strobe. Controlled by programmable DMD sequence timing (active high), (if not used, apply 1-kΩ pull-down to DGND)
LED_BLU_EN	F27	O <sub>3</sub>	Async	Blue LED enable strobe. Controlled by programmable DMD sequence timing (active high), (if not used, apply 1-kΩ pull-down to DGND)
LED_SUBFRAME	E26	O <sub>3</sub>	Async	Subframe signal used by LED driver. Controlled by programmable DMD sequence timing (active high), (if not used, apply 1-kΩ pull-down to DGND)
SYNC_0	F26	O <sub>3</sub>	Async	Extra strobe. Controlled by programmable DMD sequence timing (active-high)
SYNC_1	F25	O <sub>3</sub>	Async	Extra strobe. Controlled by programmable DMD sequence timing (active-high)
SYNC_2	F24	O <sub>3</sub>	Async	Extra strobe. Controlled by programmable DMD sequence timing (active-high)
$\overline{\text{LED\_EN}}$	L28	O <sub>3</sub>	Async	LED driver enable. Active-low output control to external LED drive logic, recommend 1-kΩ pullup to 3.3 V
LED_SYNC	M21	O <sub>3</sub>	Async	Reserved for future use; weak pullup applied
LED_SYNCEN	C24	O <sub>3</sub>	Async	Inverted $\overline{\text{LED\_LIT}}$ signal (if not used, apply 10-kΩ pull-down to DGND)
$\overline{\text{LED\_LIT}}$	J28	I <sub>3</sub>	Async	LED driver status, (if not used, apply 1-kΩ pull-down to DGND)
LED_SENS	K27	I <sub>3</sub>	Async	Reserved for future use (if not used, apply 1-kΩ pull-down to DGND)
LED_SPI_CLK	N26	O <sub>3</sub>	Async	LED SPI master clock (if not used, apply 1-kΩ pullup to 3.3 V)
$\overline{\text{LED\_SPI\_CS}}$	M26	O <sub>3</sub>	LED_SPI_CLK	LED SPI master chip select (if not used, apply 1-kΩ pullup to 3.3 V)
LED_SPI_DIR	P25	O <sub>3</sub>	LED_SPI_CLK	LED SPI master driver direction (if not used, apply 1-kΩ pullup to 3.3 V)
LED_SPI_MISO	L27	I <sub>3</sub>	LED_SPI_CLK	LED SPI master data IN (if not used, apply 1-kΩ pullup to 3.3 V)
LED_SPI_MOSI	L26	O <sub>3</sub>	LED_SPI_CLK	LED SPI master data OUT; weak pullup applied

**Pin Functions (continued)**

PIN		I/O TYPE <sup>(1)</sup>	CLOCK SYSTEM	DESCRIPTION
NAME	NUMBER			
<b>SYSTEM INTERFACES</b>				
$\overline{\text{CFG\_CSO}}$	E2	O <sub>3</sub>	CFG_DCLK	Chip-select output for an external serial configuration device. Active low
CFG_CLK	P3	O <sub>3</sub>	CFG_DCLK	Configuration serial EPROM data clock
CFG_ASDI	N7	I <sub>3</sub>	CFG_DCLK	Data input from an external serial configuration device. Provides configuration data for the device
CFG_ASDO	F4	O <sub>3</sub>	CFG_DCLK	Serial data output. This pin sends address and control information to the external PROM during configuration.
$\overline{\text{CFG\_STATUS}}$	M6	O <sub>3</sub>	CFG_DCLK	Configuration status pin
CFG_DONE	P24	O <sub>3</sub>	CFG_DCLK	Configuration-done status pin. Signal goes high at the end of configuration.
CFG_MSEL0	N22	I <sub>3</sub>	Async	Configuration-mode selection signals
CFG_MSEL1	P23			
CFG_MSEL2	M22			
CFG_MSEL3	P22			
$\overline{\text{CFG\_CE}}$	R8	I <sub>3</sub>	Async	Chip enable. Active-low
$\overline{\text{CFG\_EN}}$	P4	I <sub>3</sub>	Async	Configuration control. Configuration starts when a low-to-high transition is detected at this pin.
$\overline{\text{CFG\_CEO}}$	P28	O <sub>3</sub>	Async	
REF_CLK	J27	I <sub>3</sub>		50-MHz reference clock, 3.3 V
$\overline{\text{RESET}}$	A14	I <sub>3</sub>	Async	Device reset (active-low)
PWR_GOOD	A23	I <sub>3</sub>	Async	System power-good indicator
<b>RESERVED</b>				
RSVD_H10	N4	B <sub>2</sub>		GPIO
RSVD_H11	L2	B <sub>2</sub>		GPIO
RSVD_H12	K4	B <sub>2</sub>		GPIO
RSVD_H6	G1	B <sub>2</sub>		GPIO
RSVD_H5	G5	B <sub>2</sub>		GPIO
RSVD_H4	G6	B <sub>2</sub>		GPIO
RSVD_H2	E1	B <sub>2</sub>		GPIO
RSVD_H1	C2	B <sub>2</sub>		GPIO
RSVD_T0	E22			These I/Os can be left open or unconnected for normal operation.
RSVD_T1	D21			
RSVD_T2	A21			
RSVD_T3	C18			
RSVD_T4	B22			
RSVD_T5	B21			
RSVD_T6	D17			
RSVD_T7	E21			
RSVD_TC	M24			
RSVD_D0	A17	I <sub>3</sub>		
RSVD_D1	D15	O <sub>3</sub>		Reserved for future use, do not connect
RSVD_D2	E17	I <sub>3</sub>		Reserved for future use, do not connect
RSVD_D3	F15	O <sub>3</sub>		Reserved for future use, do not connect
RSVD_H3	E3	I <sub>3</sub>		Reserved for future use, can be left open, recommend grounding
RSVD_H7	H7	I <sub>3</sub>		Reserved for future use, can be left open, recommend grounding
RSVD_H8	L5	I <sub>3</sub>		Reserved for future use, can be left open, recommend grounding
RSVD_H9	M5	I <sub>3</sub>		Reserved for future use, can be left open, recommend grounding



**Pin Functions (continued)**

PIN		I/O TYPE <sup>(1)</sup>	CLOCK SYSTEM	DESCRIPTION
NAME	NUMBER			
<b>RESERVED (CONTINUED)</b>				
RSVD_H13	J1	I <sub>3</sub>		Reserved for future use, can be left open, recommend grounding
RSVD_P0	P7	I <sub>4</sub>		Reserved for future use, do not connect
RSVD_P1	P6	O <sub>2</sub>		Reserved for future use, do not connect
RSVD_P2	P8	I <sub>4</sub>		Reserved for future use, do not connect
RSVD_P3	P5	I <sub>4</sub>		Reserved for future use, do not connect
RSVD_G0	C23	O <sub>3</sub>		Reserved for future use, do not connect
RSVD_G1	F19	O <sub>3</sub>		Reserved for future use, do not connect
RSVD_G2	M27	O <sub>3</sub>		Reserved for future use, do not connect
RSVD_G3	N21	O <sub>3</sub>		Reserved for future use, do not connect
RSVD_G4	P27	O <sub>3</sub>		Reserved for future use, do not connect
RSVD_G5	A18	O <sub>3</sub>		Reserved for future use, do not connect
RSVD_G6	A19	O <sub>3</sub>		Reserved for future use, do not connect
RSVD_S1	AG14			Unused input only, can be left open, recommend 10-kΩ pulldown to DGND
RSVD_S2	AG15			Unused input only, can be left open, recommend 10-kΩ pulldown to DGND
RSVD_S3	AH14			Unused input only, can be left open, recommend 10-kΩ pulldown to DGND
RSVD_X11	AH15			Unused input only, can be left open, recommend 10-kΩ pulldown to DGND
RSVD_S20	Y27			Unused input only, can be left open, recommend 10-kΩ pulldown to DGND
RSVD_S21	Y28			Unused input only, can be left open, recommend 10-kΩ pulldown to DGND
RSVD_X9	AA22			Reserved for future use, do not connect
RSVD_S0	AA24			Reserved for future use, can be left open, recommend 10-kΩ pullup to 2.5 V
RSVD_X10	AB23			Reserved for future use, do not connect
RSVD_X6	AB24			Reserved for future use, do not connect
RSVD_X3	AC21			Reserved for future use, do not connect
RSVD_X15	AA17			Reserved, do not leave open, required: 49.4-Ω pullup to 1.8 V
RSVD_X14	AB17			Reserved, do not leave open, required: 49.9-Ω pulldown to DGND
RSVD_X13	U7			Reserved, do not leave open, required: 49.4-Ω pullup to 1.8V
RSVD_X12	U8			Reserved, do not leave open, required: 49.9-Ω pulldown to DGND
RSVD_X2	AE15			Reserved for future use, do not connect
RSVD_X0	AF18			Reserved for future use, do not connect
RSVD_X1	AD15			Reserved for future use, do not connect
RSVD_X8	AF27			Reserved for future use, do not connect
RSVD_X4	AF9			Reserved for future use, do not connect
RSVD_S4	AH26			Reserved for future use, can be left open, recommend 10-kΩ pullup to 1.8 V
RSVD_S5	B25			Reserved for future use, do not connect
RSVD_S6	C20			Reserved for future use, do not connect
RSVD_S8	D19			Reserved for future use, do not connect
RSVD_X5	E24			Reserved for future use, do not connect
RSVD_S10	F22			Reserved for future use, do not connect

**Pin Functions (continued)**

PIN		I/O TYPE <sup>(1)</sup>	CLOCK SYSTEM	DESCRIPTION
NAME	NUMBER			
<b>RESERVED (CONTINUED)</b>				
RSVD_S11	K28			Reserved for future use, do not connect
RSVD_S14	N25			Reserved for future use, do not connect
RSVD_X7	R24			Reserved for future use, do not connect
RSVD_S16	R27			Reserved for future use, do not connect
RSVD_S17	R28			Reserved for future use, do not connect
RSVD_S18	U23			Reserved for future use, can be left open, recommend 10-kΩ pullup to 2.5 V
RSVD_S19	U24			Reserved for future use, can be left open, recommend 10-kΩ pullup to 2.5 V
<b>POWER AND GROUND<sup>(3)</sup></b>				
P1P2V		PWR	N/A	1.2-V core power
P2P5V_DPLL		PWR	N/A	2.5-V filtered power for internal PLL
P1P8V		PWR	N/A	1.8-V I/O power
P2P5V		PWR	N/A	2.5-V I/O power
P3P3V		PWR	N/A	3.3-V I/O power
GND		PWR	N/A	Common digital ground
GND A		PWR	N/A	Common PLL ground

(3) Unused inputs should be pulled down to ground through an external resistor.

**Power and Ground Pins**

PIN		DESCRIPTION
NAME	NUMBER	
<b>INPUT POWER AND GROUND PINS</b>		
VCC_1P2V	K9, K11, K13, K15, K17, K19, L10, L12, L14, L16, L18, L20, M9, M11, M13, M15, M17, M19, N10, N12, N14, N16, N18, N20, P9, P11, P13, P15, P17, P19, R10, R12, R14, R16, R18, R20, T9, T11, T13, T15, T17, T19, U10, U12, U14, U16, U18, U20, V9, V11, V13, V15, V17, V19, W10, W12, W14, W16, W18, W20	1.2-V power supply for core logic
VCC_2P5V	AA28, AG28, T24, T28, W24	2.5-V power supply for I/Os on bank 5
VCC_1P8V	AA1, AG1, T1, T5, W5, AA11, AD6, AD9, AD13, AH2, AH5, AH9, AH13, AA18, AD16, AD20, AD23, AH16, AH20, AH24, AH27	1.8-V power supply for I/Os on banks 2, 3, 4
VCC_3P3V	B1, H1, K5, N1, N5, B28, H28, K24, N24, N28 A16, A20, A24, A27, E16, E20, E23, H18, A2, A5, A9, A13, E6, E9, E13, H11	3.3-V power supply for I/Os on banks 1, 6, 7, 8
VCCA	Y8, J21, J8, Y21	2.5-V power supply for the internal PLL analog supply
VCCD_PLL	Y9, J20, J9, Y20	1.2-V power supply for the internal PLL digital supply
VREF_B2	T7, T8, AB4	DDR2 VREF 0.9 V. The SDRAM specification provides guidelines on how these references should be connected. It is not just any 0.9-V source on the board.
VREF_B3	AB13, AB11, Y10	DDR2 VREF 0.9 V. The SDRAM specification provides guidelines on how these references should be connected. It is not just any 0.9-V source on the board.
VREF_B4	AB20, AC18, AA15	DDR2 VREF 0.9 V. The SDRAM specification provides guidelines on how these references should be connected. It is not just any 0.9-V source on the board.
DGND	K10, K12, K14, K16, K18, K20, L9, L11, L13, L15, L17, L19, M10, M12, M14, M16, M18, M20, N9, N11, N13, N15, N17, N19, P10, P12, P14, P16, P18, P20, R9, R11, R13, R15, R17, R19, T10, T12, T14, T16, T18, T20, U9, U11, U13, U15, U17, U19, V10, V12, V14, V16, V18, V20, W9, W11, W13, W15, W17, W19, AA2, AA27, AC6, AC9, AC13, AC16, AC20, AC23, AF1, AF28, AG2, AG5, AG9, AG13, AG16, AG20, AG24, AG27, B2, B5, B9, B13, B16, B20, B24, B27, C1, C28, F6, F9, F13, F16, F20, F23, H2, H27, J11, J18, K6, K23, N2, N6, N23, N27, T2, T6, T23, T27, W6, W23, Y11, Y18	Common ground
DGND2	H9, H20, AA9, AA20	Analog ground return for the PLL (This should not be connected to the common ground GND.)
NC	C3, F7, G7, G8, G10, G11, G19, G20, G21, G22, G23, G24, H8, H10, H12, H14, H15, H16, H17, H19, H21, H22, J5, J6, J7, J10, J12, J13, J14, J15, J16, J17, J19, J23, J24, K7, K8, K21, K22, L6, L7, L8, L21, L22, M7, M8, M23, N8, P21, R7, R21, R22, R23, U21, U22, V5, V6, V7, V8, V21, V22, W4, W7, W8, W21, W22, Y5, Y6, Y7, Y12, Y13, Y14, Y15, Y16, Y17, Y22, AA5, AA6, AA7, AA12, AA13, AA14, AA19, AA21, AA23, AB10, AB12, AB14, AB15, AB18, AB19, AB21, AB22, AC10, AC12, AC14, AC19, AC22, AD14, AD19, AD22, AE26	No-connect pins

## 6 Specifications

### 6.1 Absolute Maximum Ratings<sup>(1)</sup>

Over operating free-air temperature range (unless otherwise noted)

		MIN	MAX	UNIT
$V_{CC12}$	Supply voltage <sup>(2)</sup>	-0.5	1.8	V
$V_{CCIO18}$		-0.5	3.9	
$V_{CCA25\_DPLL}$		-0.5	3.75	
$V_{CCD\_PLL1-4}$		-0.5	1.8	
$V_I$	Input voltage <sup>(3)</sup> (1.8 V, 2.5 V, 3.3 V)	-0.5	3.95	V
$T_J$	Operating junction temperature	-40	125	°C

- (1) Stresses beyond those listed under *Absolute Maximum Ratings* may cause permanent damage to the device. These are stress ratings only, and functional operation of the device at these or any other conditions beyond those indicated under *Recommended Operating Conditions* is not implied. Exposure to absolute-maximum-rated conditions for extended periods may affect device reliability.
- (2) All voltage values are with respect to GND, and at the device, not at the power supply.
- (3) Applies to external input and bidirectional buffers.

### 6.2 Handling Ratings

		MIN	MAX	UNIT	
$T_{stg}$	Storage temperature range	-65	150	°C	
$V_{(ESD)}$	Electrostatic discharge	Human body model (HBM), per ANSI/ESDA/JEDEC JS-001, all pins <sup>(1)</sup>	-2000	2000	V
		Charged device model (CDM), per JEDEC specification JESD22-C101, all pins <sup>(2)</sup>	-500	500	

- (1) JEDEC document JEP155 states that 500-V HBM allows safe manufacturing with a standard ESD control process.
- (2) JEDEC document JEP157 states that 250-V CDM allows safe manufacturing with a standard ESD control process.

### 6.3 Recommended Operating Conditions

Over operating free-air temperature range (unless otherwise noted)

		MIN	NOM	MAX	UNIT
$V_{CC12}$	1.2-V supply voltage, core logic	1.15	1.2	1.25	V
$V_{CC18}$	1.8-V supply voltage, HSTL output buffers	1.71	1.8	1.89	V
$V_{CCA25\_DPLL}$	2.5-V analog voltage for PLL regulator	2.375	2.5	2.625	V
$V_{CCD\_PLL1-4}$	1.2-V supply voltage, for PLL	1.15	1.2	1.25	V
$V_{CC33}$	3.3-V supply voltage	3.135	3.3	3.465	V
$V_{REF\_B2-4}$	0.9-V reference voltage, for DDR2 SDRAM	0.833	0.9	0.969	V
$V_I$	Input voltage	-0.5		3.6	V
$V_O$	Output voltage	0		$V_{CCIO}$	V
$t_{Ramp}$	Power supply ramp time	50 $\mu$ s		3 ms	—
$T_J$	Operating junction temperature <sup>(1)</sup>	-20		85	°C

- (1) Heat sink not required for 0°C to 55°C, but for 55°C to 85°C, TI recommends a low-profile (15-mm) heat sink.

### 6.4 Thermal Information

THERMAL METRIC <sup>(1)</sup>		DLPC200	UNIT	
		BGA		
		780 PINS		
$R_{\theta JA}$	Junction-to-ambient thermal resistance	Natural convection	16.9	°C/W
		100 CFM	13.5	
		200 CFM	11.8	
		400 CFM	10.5	
$R_{\theta JC(top)}$	Junction-to-case (top) thermal resistance	3.3		
$R_{\theta JB}$	Junction-to-board thermal resistance	5.9		

- (1) For more information about traditional and new thermal metrics, see the *IC Package Thermal Metrics* application report, [SPRA953](http://SPRA953).

## 6.5 I/O Electrical Characteristics

All inputs and outputs are LVCMOS

I/O TYPE <sup>(1)</sup>	TEST CONDITIONS	V <sub>IL</sub> (V)		V <sub>IH</sub> (V)		V <sub>OH</sub> (V)	V <sub>OL</sub> (V)	UNIT
		MIN	MAX	MIN	MAX	MIN	MAX	
I <sub>1</sub> Input LVCMOS	V <sub>CCIO</sub> = 1.8 V	-0.3	0.35 × V <sub>CCIO</sub>	0.65 × V <sub>CCIO</sub>	2.25			V
I <sub>2</sub> Input LVCMOS	V <sub>CCIO</sub> = 2.5 V	-0.3	0.7	1.7	V <sub>CCIO</sub> + 0.3			V
I <sub>3</sub> Input LVCMOS	V <sub>CCIO</sub> = 3.3 V	-0.3	0.8	1.7	3.6			V
I <sub>4</sub> Input LVTTTL	V <sub>CCIO</sub> = 3.3 V	-0.3	0.8	1.7	3.6			V
O <sub>1</sub> Output LVCMOS	V <sub>CCIO</sub> = 1.8 V					V <sub>CCIO</sub> - 0.45	0.45	V
O <sub>2</sub> Output LVTTTL	V <sub>CCIO</sub> = 3.3 V					2.4	0.45	V
O <sub>3</sub> Output LVCMOS	V <sub>CCIO</sub> = 3.3 V					V <sub>CCIO</sub> - 0.2	0.2	V
O <sub>4</sub> Output LVDS	V <sub>CCIO</sub> = 3.3 V					V <sub>CCIO</sub> - 0.3	0.3	V
O <sub>5</sub> Output SSTL-18 Class I	V <sub>CCIO</sub> = 1.8 V					1.484	0.398	V
B <sub>1</sub> Bidirectional SSTL-18 Class I	V <sub>CCIO</sub> = 1.8 V		0.844	1.094		1.484	0.398	V
B <sub>2</sub> Bidirectional LVCMOS	V <sub>CCIO</sub> = 3.3 V	-0.3	0.8	1.7	3.6	V <sub>CCIO</sub> - 0.2	0.2	V

(1) Cross reference to I/O assignments

## 6.6 Video Input Pixel Interface Timing Requirements

PARAMETER	TEST CONDITIONS	MIN	MAX	UNIT
f <sub>pclock</sub> Clock frequency, PORTx_CLK			80	MHz
t <sub>p_wh</sub> Pulse duration, high	45% to 55% reference points (signal)	5.6		ns
t <sub>p_wl</sub> Pulse duration, low	45% to 55% reference points (signal)	5.6		ns
t <sub>p_su</sub> Setup time, PORTx_D(23-0) valid before PORTx_CLK	See <sup>(1)</sup>	1.5		ns
t <sub>p_h</sub> Hold time, PORTx_D(23-0) valid after PORTx_CLK	See <sup>(1)</sup>	1.5		ns
t <sub>p_su</sub> Setup time, PORTx_VSYNC valid before PORTx_CLK	See <sup>(1)</sup>	1.5		ns
t <sub>p_h</sub> Hold time, PORTx_VSYNC valid after PORTx_CLK	See <sup>(1)</sup>	1.5		ns
t <sub>p_su</sub> Setup time, PORTx_HSYNC valid before PORTx_CLK	See <sup>(1)</sup>	1.5		ns
t <sub>p_h</sub> Hold time, PORTx_HSYNC valid after PORTx_CLK	See <sup>(1)</sup>	1.5		ns
t <sub>p_su</sub> Setup time, PORTx_IVALID valid before PORTx_CLK	See <sup>(1)</sup>	1.5		ns
t <sub>p_h</sub> Hold time, PORTx_IVALID valid after PORTx_CLK	See <sup>(1)</sup>	1.5		ns

(1) PCLK may be inverted from that shown in [Figure 1](#). In that case, the same specifications in the table are valid except now referenced to the falling edge of the clock. If the falling edge of PCLK is used, a USB or SPI command must be sent to tell the DLPC200 to use the falling edge of PCLK.

DLPC200

DLPS014F – APRIL 2010 – REVISED MAY 2018

www.ti.com

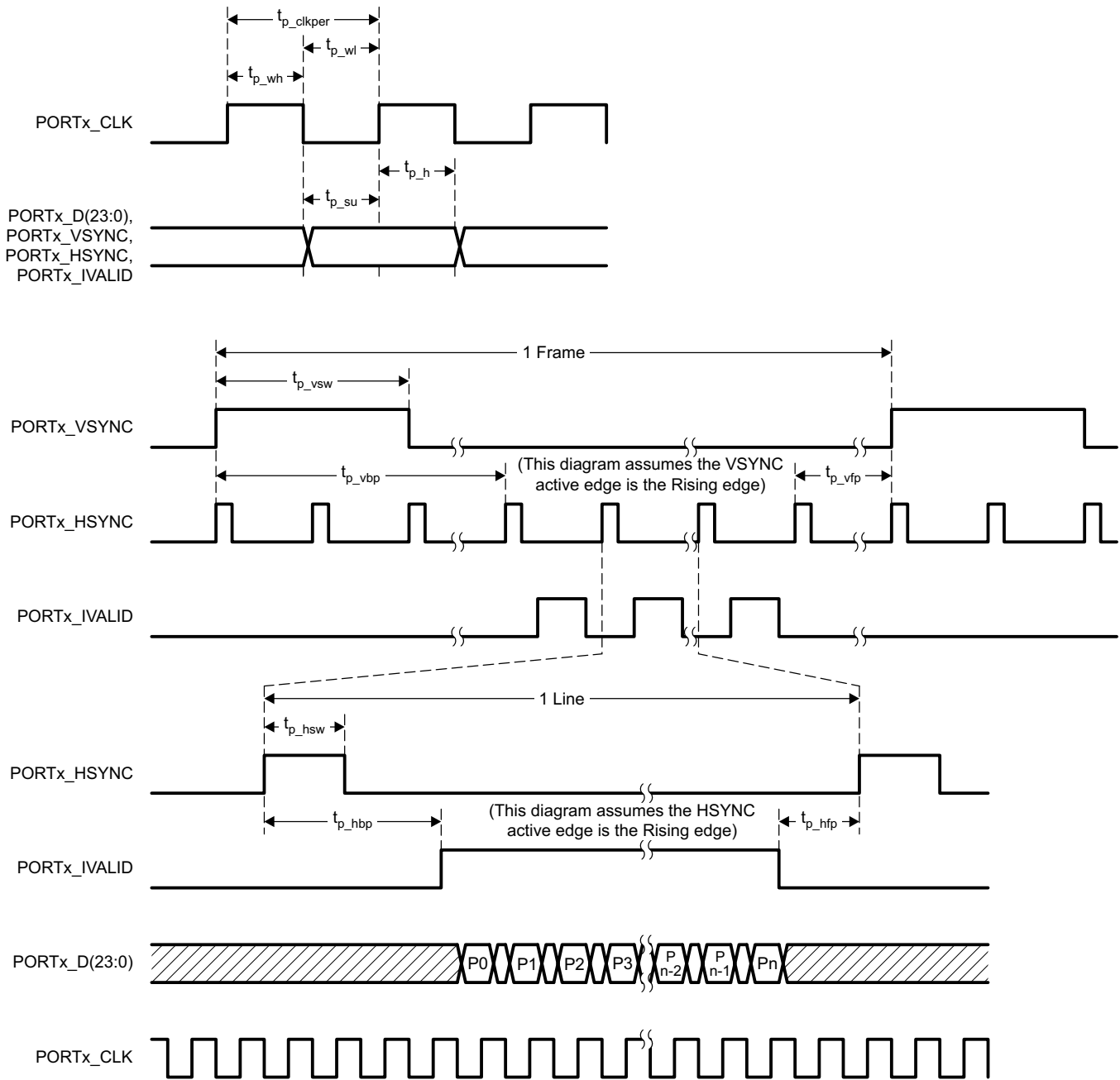
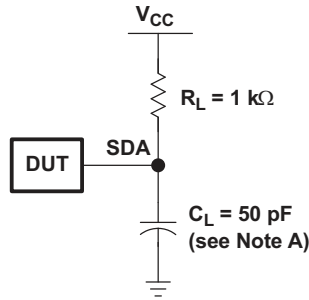

Figure 1. Input Port Interface

See [Pin Configuration and Functions](#) for the proper connection schema if a video input port will not be used.

## 6.7 I<sup>2</sup>C Interface Timing Requirements

PARAMETER		MIN	MAX	UNIT
$f_{scl}$	I <sup>2</sup> C clock frequency	0	400	kHz
$t_{sch}$	I <sup>2</sup> C clock high time	1		ms
$t_{scl}$	I <sup>2</sup> C clock low time	1		ms
$t_{sp}$	I <sup>2</sup> C spike time		20	ns
$t_{sds}$	I <sup>2</sup> C serial-data setup time	100		ns
$t_{sdh}$	I <sup>2</sup> C serial-data hold time	100		ns
$t_{icr}$	I <sup>2</sup> C input rise time	100		ns
$t_{ocf}$	I <sup>2</sup> C output fall time	30	200	ns
$t_{buf}$	I <sup>2</sup> C bus free time between stop and start conditions	1.3		ms
$t_{sts}$	I <sup>2</sup> C start or repeat start condition setup	1		ms
$t_{sth}$	I <sup>2</sup> C start or repeat start condition hold	1		ms
$t_{sph}$	I <sup>2</sup> C stop condition setup	1		ms
$t_{vd}$	Valid-data time	SCL low to SDA output valid		1 ms
	Valid-data time of ACK condition	ACK signal from SCL low to SDA (out) low		1 ms
$t_{sch}$	I <sup>2</sup> C bus capacitive load	0	100	pF



SDA LOAD CONFIGURATION

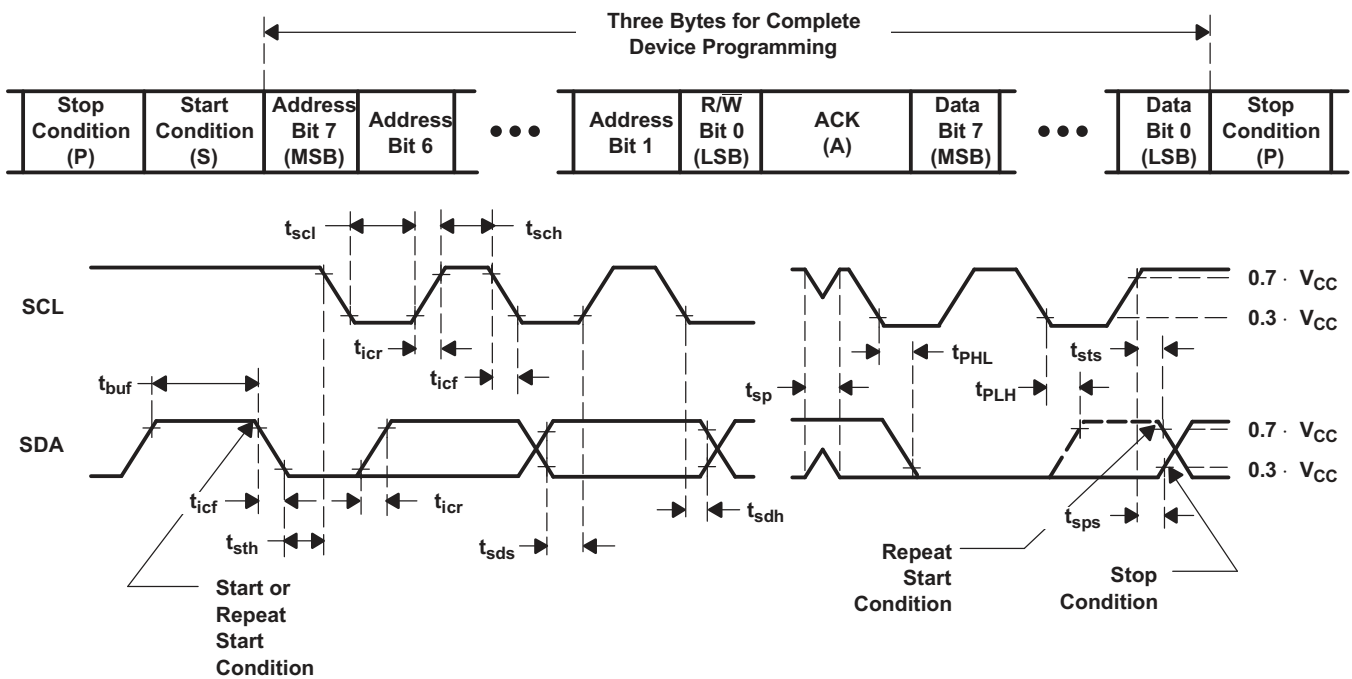

VOLTAGE WAVEFORMS

BYTE	DESCRIPTION
1	I <sup>2</sup> C address
2, 3	P-port data

Figure 2. I<sup>2</sup>C Interface Load Circuit and Voltage Waveforms



### 6.8 USB Read Interface Timing Requirements

PARAMETER		MIN	TYP	MAX	UNIT
$t_{CL}$	1 / CLKOUT frequency		20.8		ns
$t_{AV}$	Delay from clock to valid address			10.7	ns
$t_{STBL}$	Clock to USB_RDY0 LOW			11	ns
$t_{STBH}$	Clock to USB_RDY0 HIGH			11	ns
$t_{SCSL}$	Clock to USB_PA02 LOW			13	ns
$t_{DSU}$	Data setup to clock	9.6			ns
$t_{DH}$	Data hold time	0			ns
$t_{ACC1}$	Valid USB_PA04 to valid USB_FDC	43			ns

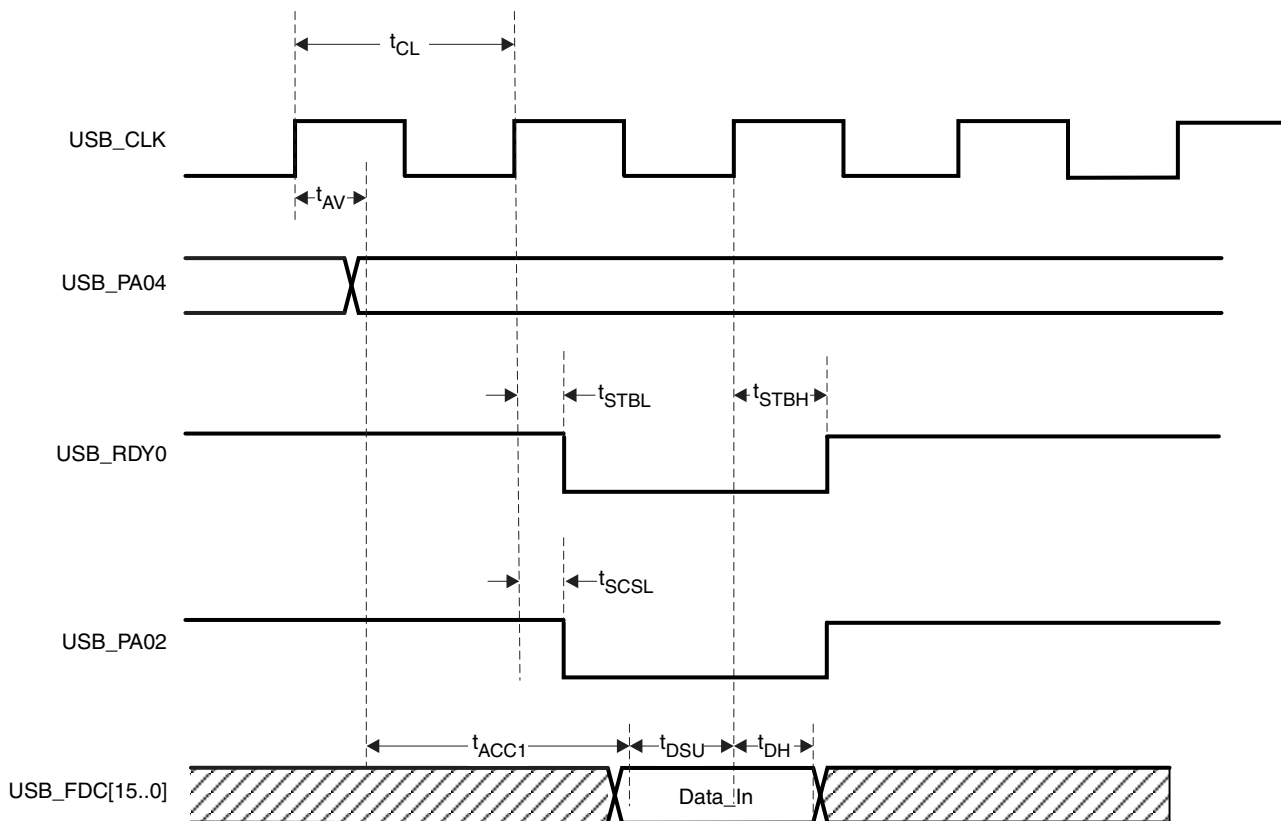
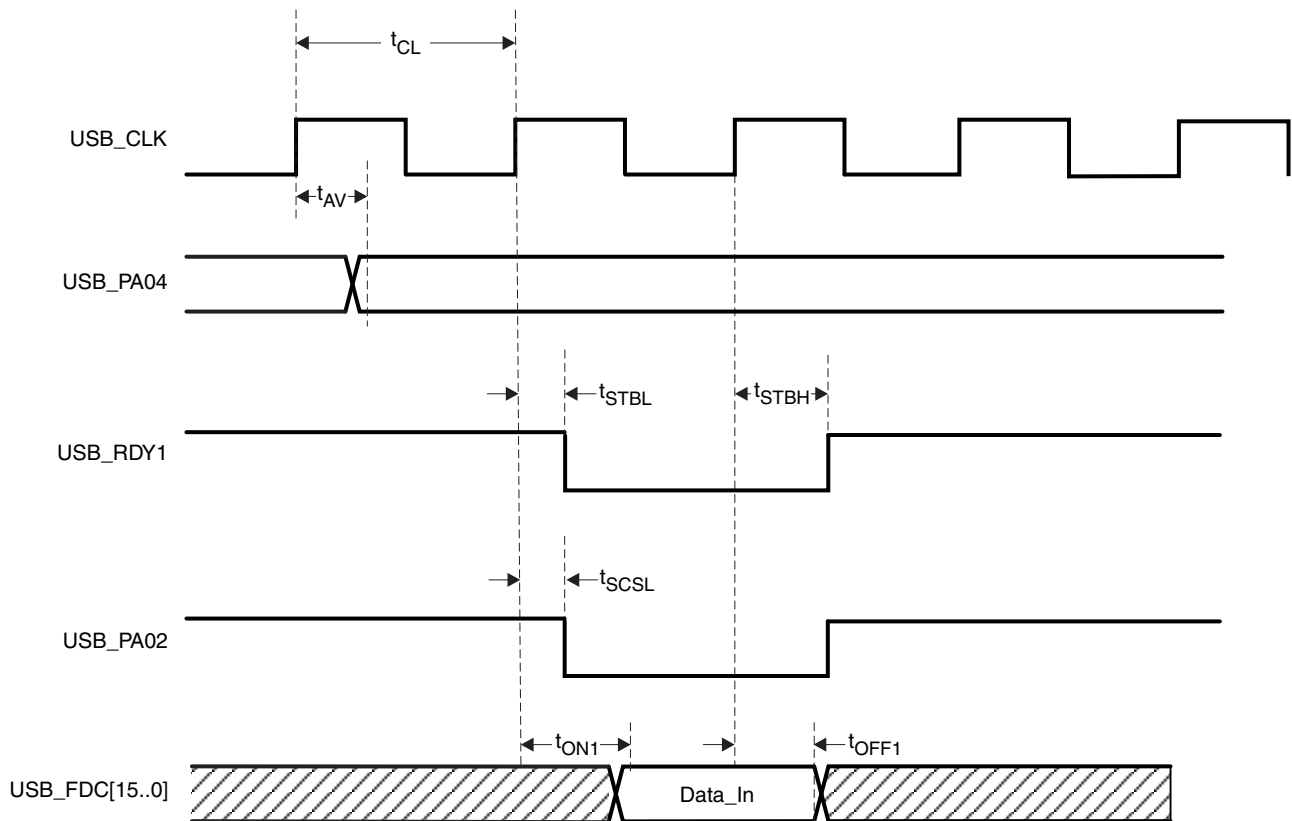

Figure 3. USB Read Timing

## 6.9 USB Write Interface Timing Requirements

PARAMETER		MIN	MAX	UNIT
$t_{AV}$	Delay from clock to valid address	0	10.7	ns
$t_{STBL}$	Clock to USB_RDY1 pulse LOW	0	11.2	ns
$t_{STBH}$	Clock to USB_RDY1 pulse HIGH	0	11.2	ns
$t_{SCSL}$	Clock to USB_PA02 pulse LOW		13	ns
$t_{ON1}$	Clock to data turn on	0	13.1	ns
$t_{OFF1}$	Clock to data hold time	0	13.1	ns



**Figure 4. USB Write Timing**

See [Pin Configuration and Functions](#) for the proper connection schema if the USB interface will not be used.

### 6.10 SPI Slave Interface Timing Requirements

PARAMETER		MIN	MAX	UNIT
$f_{\text{clock}}$	Clock frequency, SLAVE_SPI_CLK		5	MHz
$t_{\text{p\_clkper}}$	Clock period, SLAVE_SPI_CLK	200		ns
$t_{\text{p\_wh}}$	Pulse duration high, SLAVE_SPI_CLK	10		ns
$t_{\text{p\_wl}}$	Pulse duration low, SLAVE_SPI_CLK	10		ns
$t_{\text{c\_su}}$	Setup time, SLAVE_SPI_CS	6		ns
$t_{\text{c\_h}}$	Hold time, SLAVE_SPI_CS	3		ns
$t_{\text{i\_su}}$	Setup time, SLAVE_SPI_MOSI	10		ns
$t_{\text{i\_h}}$	Hold time, SLAVE_SPI_MOSI	10		ns
$t_{\text{o\_su}}$	Setup time, SLAVE_SPI_MISO	10		ns
$t_{\text{o\_h}}$	Hold time, SLAVE_SPI_MISO	10		ns
$t_{\text{a\_su}}$	Setup time, SLAVE_SPI_ACK	7		ns
$t_{\text{a\_h}}$	Hold time, SLAVE_SPI_ACK	7		ns

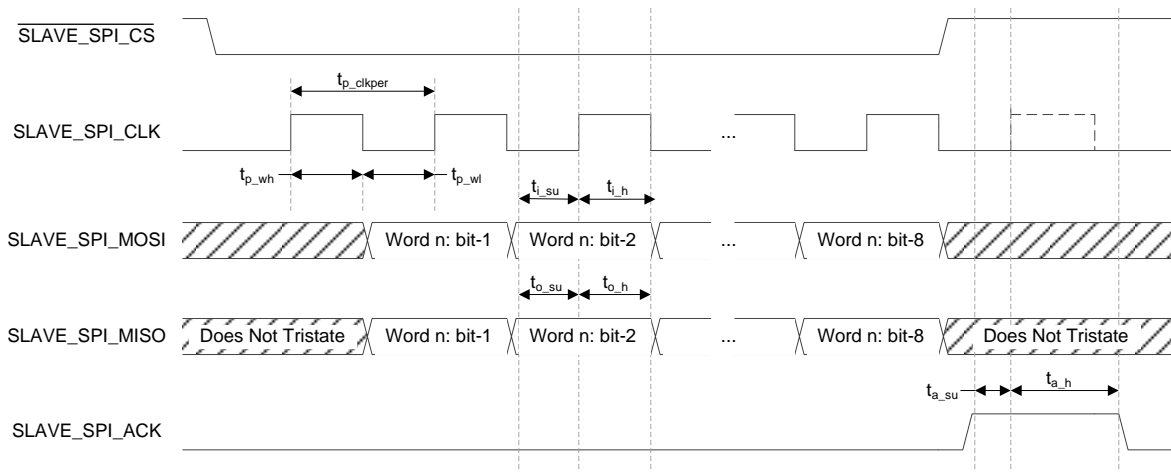

Figure 5. SPI Timing

## 6.11 Parallel Flash Interface Timing Requirements

PARAMETER		MIN	MAX	UNIT
$t_{AVAV}$	Read cycle time		110	ns
$t_{AVQV}$	Address to output valid		110	ns
$t_{ELQV}$	$\overline{CE}$ low to output valid		110	ns
$t_{GLQV}$	$\overline{OE}$ low to output valid		25	ns
$t_{PHQV}$	$\overline{RST}$ high to output valid		150	ns
$t_{GLTV}$	$\overline{OE}$ low to WAIT valid		17	ns
$t_{PHWL}$	$\overline{RST}$ high recovery to $\overline{WE}$ low	150		ns
$t_{ELWL}$	$\overline{CE}$ setup to $\overline{WE}$ low	0		ns
$t_{WLWH}$	$\overline{WE}$ write pulse width low	50		ns
$t_{DVWH}$	Data setup to $\overline{WE}$ high	50		ns
$t_{AVWH}$	Address setup to $\overline{WE}$ high	50		ns
$t_{WHEH}$	$\overline{CE}$ hold from $\overline{WE}$ high	0		ns
$t_{PWDHX}$	Data hold from $\overline{WE}$ high	0		ns
$t_{WHAX}$	Address hold from $\overline{WE}$ high	0		ns

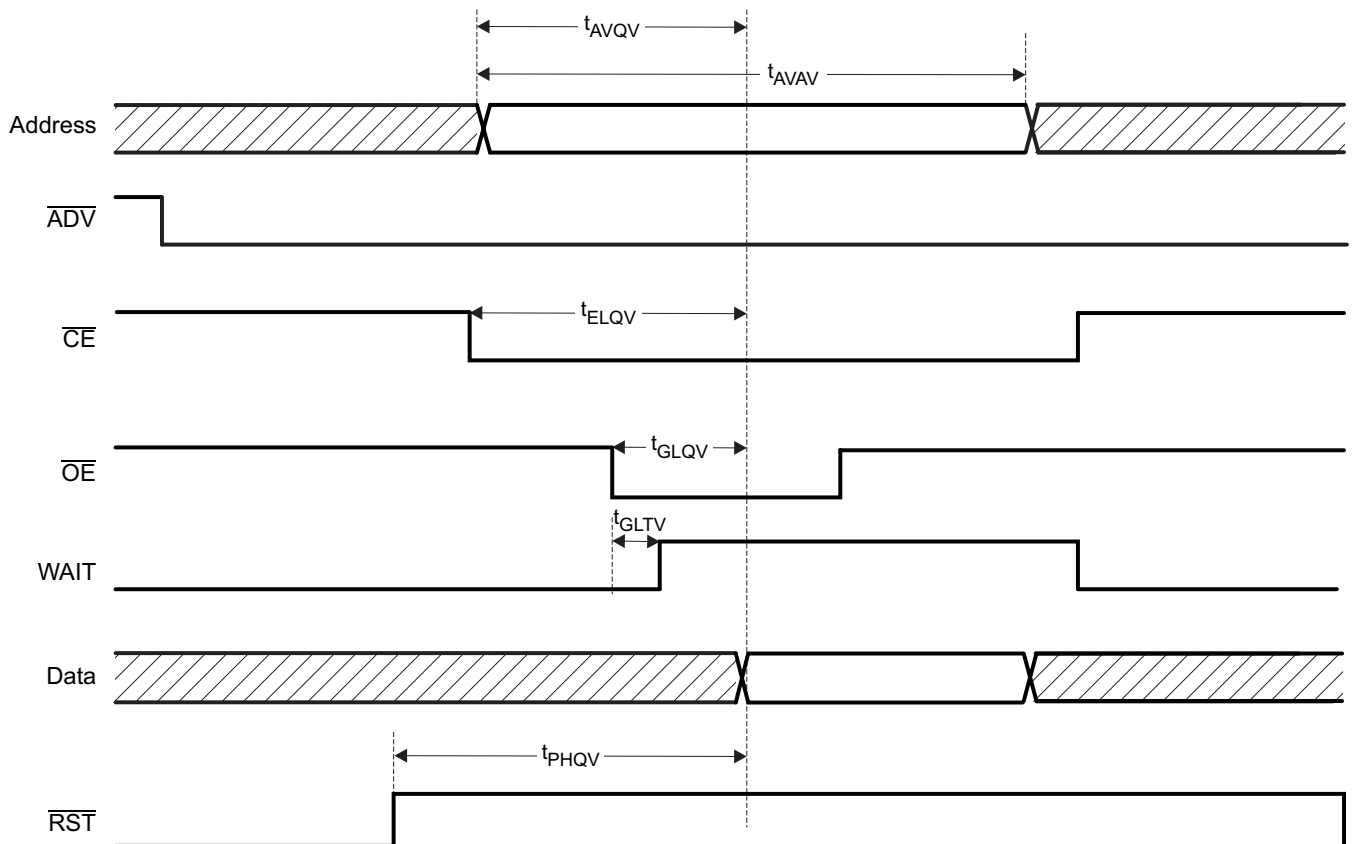

Figure 6. Parallel Flash Read Timing

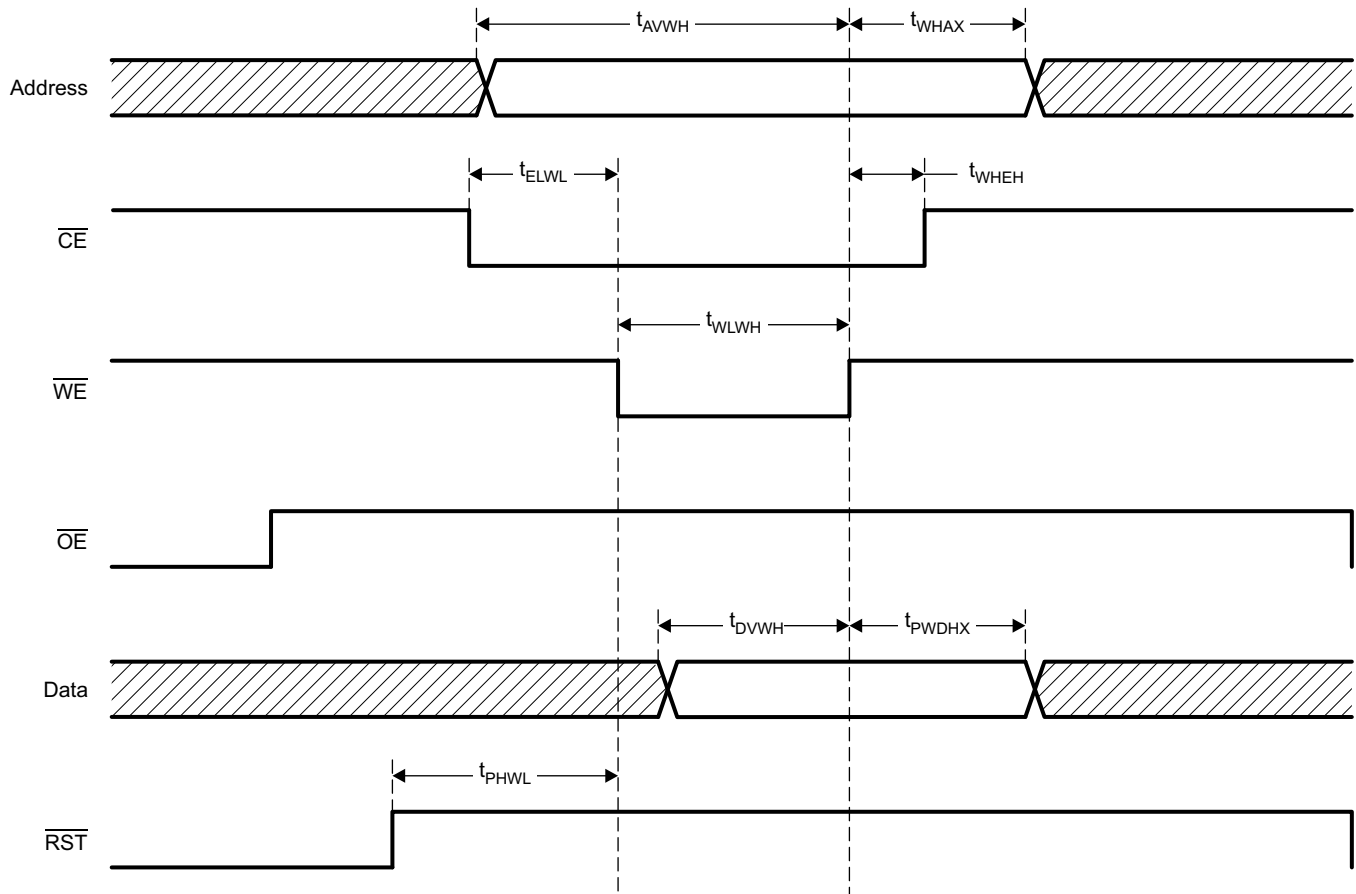
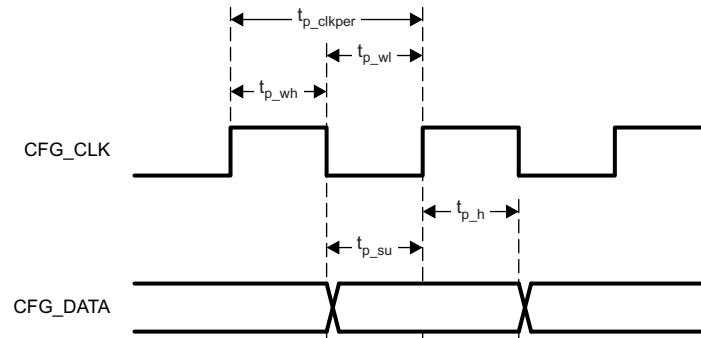

Figure 7. Parallel Flash Write Timing

## 6.12 Serial Flash Interface Timing Requirements

The DLPC200 controller flash memory interface consists of a SPI flash serial interface at 33.3 MHz (nominal).

PARAMETER		MIN	MAX	UNIT
$f_{\text{clock}}$	Clock frequency, CFG_CLK	dc	33	MHz
$t_{\text{p\_clkper}}$	Clock period, CFG_CLK		30.03	ns
$t_{\text{p\_wh}}$	Pulse duration low, CFG_CLK	6		ns
$t_{\text{p\_wl}}$	Pulse duration high, CFG_CLK	6		ns
$t_{\text{p\_su}}$	Setup time – CFG_ASDI/CFG_ASDO valid before CFG_CLK rising edge	2		ns
$t_{\text{p\_h}}$	Hold time – CFG_ASDI/CFG_ASDO valid after CFG_CLK rising edge	5		ns



**Figure 8. Flash Memory Interface Timing**

### 6.13 Static RAM Interface Timing Requirements

The DLPC200 controller static RAM (SRAM) interface consists of a high performance CMOS SRAM organized as 128K words by 16 bits (2 Mb).

PARAMETER		MIN	MAX	UNIT
$t_{RC}$	Read cycle time	10		ns
$t_{AA}$	Address to data valid		10	ns
$t_{OHA}$	Data hold from address change	3		ns
$t_{WC}$	Write cycle time	10		ns
$t_{SCE}$	CE low to write end	7		ns
$t_{AW}$	Address setup to write end	7		ns
$t_{HA}$	Address hold from write end	0		ns
$t_{SA}$	Address setup to write start	0		ns
$t_{PWE}$	WE pulse duration	7		ns
$t_{SD}$	Data setup to write end	5		ns
$t_{HD}$	Data hold from write end	0		ns

### 6.14 DMD Interface Timing Requirements

The DLPC200-DMD interface consists of a 200 MHz (nominal) DDR output-only interface with LVDS signaling.

PARAMETER		MIN	TYP	MAX	UNIT
$f_{clock}$	Clock frequency, DCLK_A and DCLK_B		200		MHz
$t_{p\_clkper}$	Clock period, DCLK_A and DCLK_B		5		ns
$t_{p\_wh}$	Pulse duration low, DCLK_A and DCLK_B		1.25		ns
$t_{p\_wl}$	Pulse duration high, DCLK_A and DCLK_B		1.25		ns
$t_{skew}$	Channel B relative to channel A	-1.25		1.25	ns
$t_{p\_su}$	Output setup time – D_A(0:15) and D_B(0:15) relative to both rising and falling edges of DCLK_A and DCLK_B, respectively	0.35			ns
$t_{p\_h}$	Output hold time – D_A(0:15) and D_B(0:15) relative to both rising and falling edges of DCLK_A and DCLK_B, respectively	0.35			ns

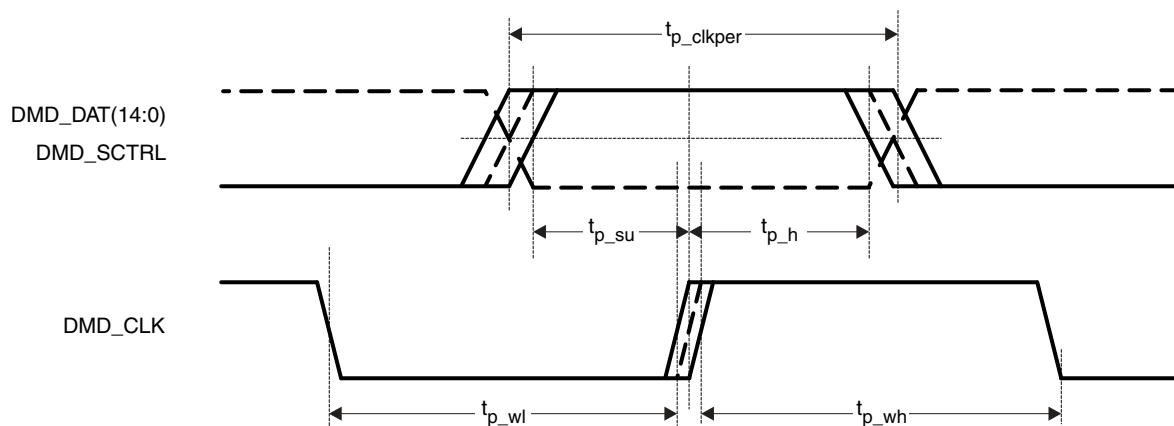
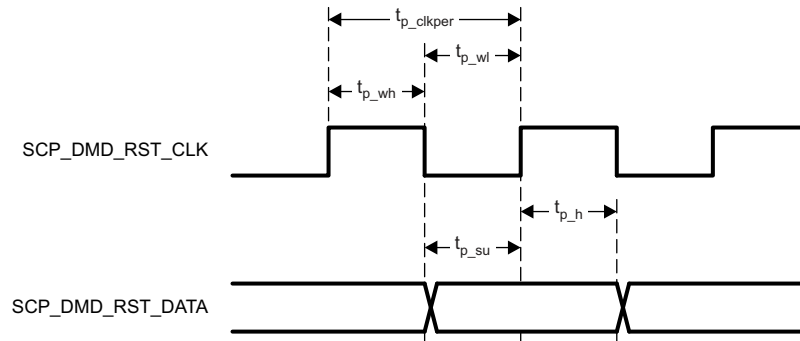

Figure 9. DMD I/F Timing

## 6.15 DLPA200 Interface Timing Requirements

The DLPC200 interface to the DLPA200 consists of a 125 kHz (nominal) serial communications port (SCP).

PARAMETER		MIN	TYP	MAX	UNIT
$f_{\text{clock}}$	Clock frequency		125	125	kHz
$t_{\text{p\_clkper}}$	Clock period			8	us
$t_{\text{p\_wh}}$	Pulse duration low			4	us
$t_{\text{p\_wl}}$	Pulse duration high			4	us
$t_{\text{p\_su}}$	SCPDI setup time	7.3			ns
$t_{\text{p\_h}}$	SCPDI hold time	5.7			ns



**Figure 10. DLPA200 I/F Timing**



### 6.16 DDR2 SDR Memory Interface Timing Requirements

PARAMETER		MIN	MAX	UNIT
$t_{CYCLE}$	Cycle time reference	5	8	ns
$t_{CH}$	CK high pulse duration <sup>(1)</sup>	2.4	4.16	ns
$t_{CL}$	CK low pulse duration <sup>(1)</sup>	2.4	4.16	ns
$t_{CMS}$	Command setup	200		ps
$t_{CMH}$	Command hold	275		ps
$t_{AS}$	Address setup	400		ps
$t_{AH}$	Address hold	400		ps
$t_{DS}$	Write data setup	1.5		ns
$t_{DH}$	Write data hold	1.5		ns
$t_{AC}$	Read data access time	-450	450	ps
$t_{OH}$	Read data hold time		340	ps
$t_{LZ}$	Read data low-impedance time	-900	450	ps
$t_{HZ}$	Read data high-impedance time		450	ps

(1) Output setup/hold numbers already account for controller clock jitter. Only routing skew and memory setup/hold need be considered in system timing analysis.

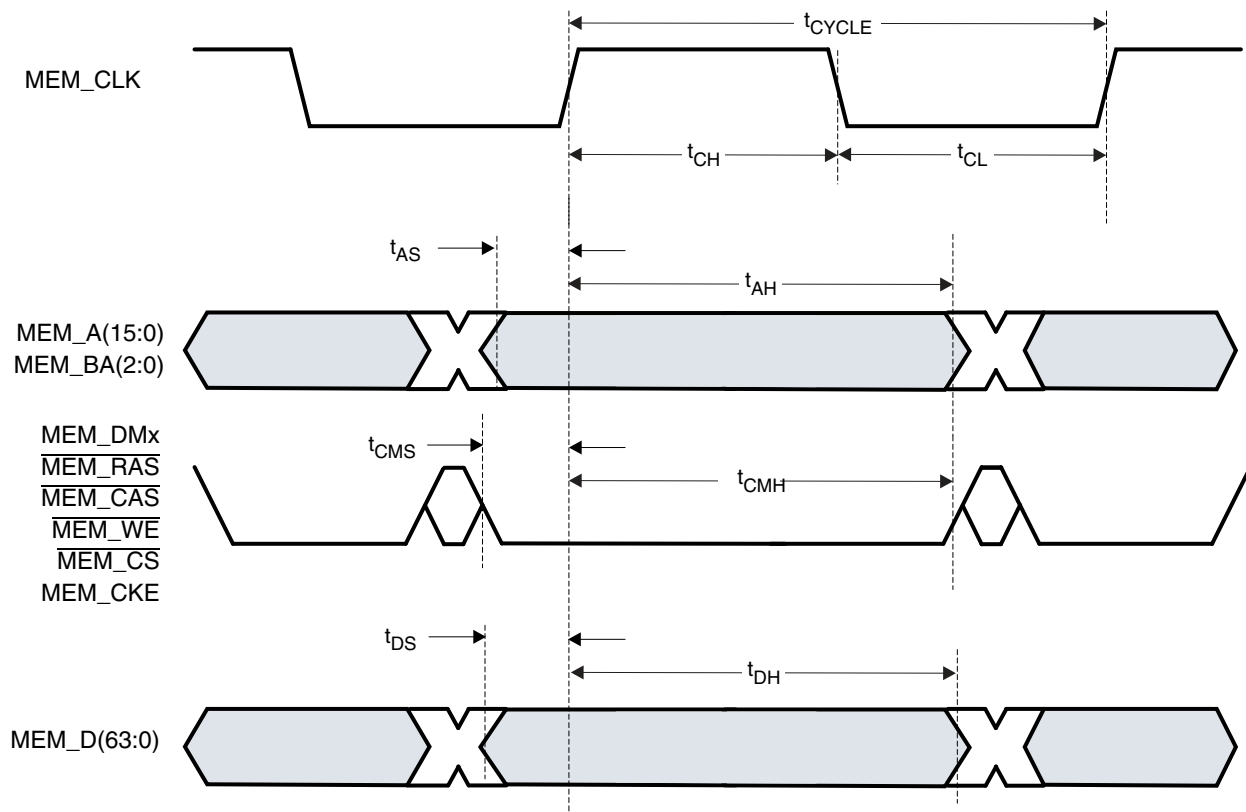

Figure 11. SDR Memory I/F Write Timing

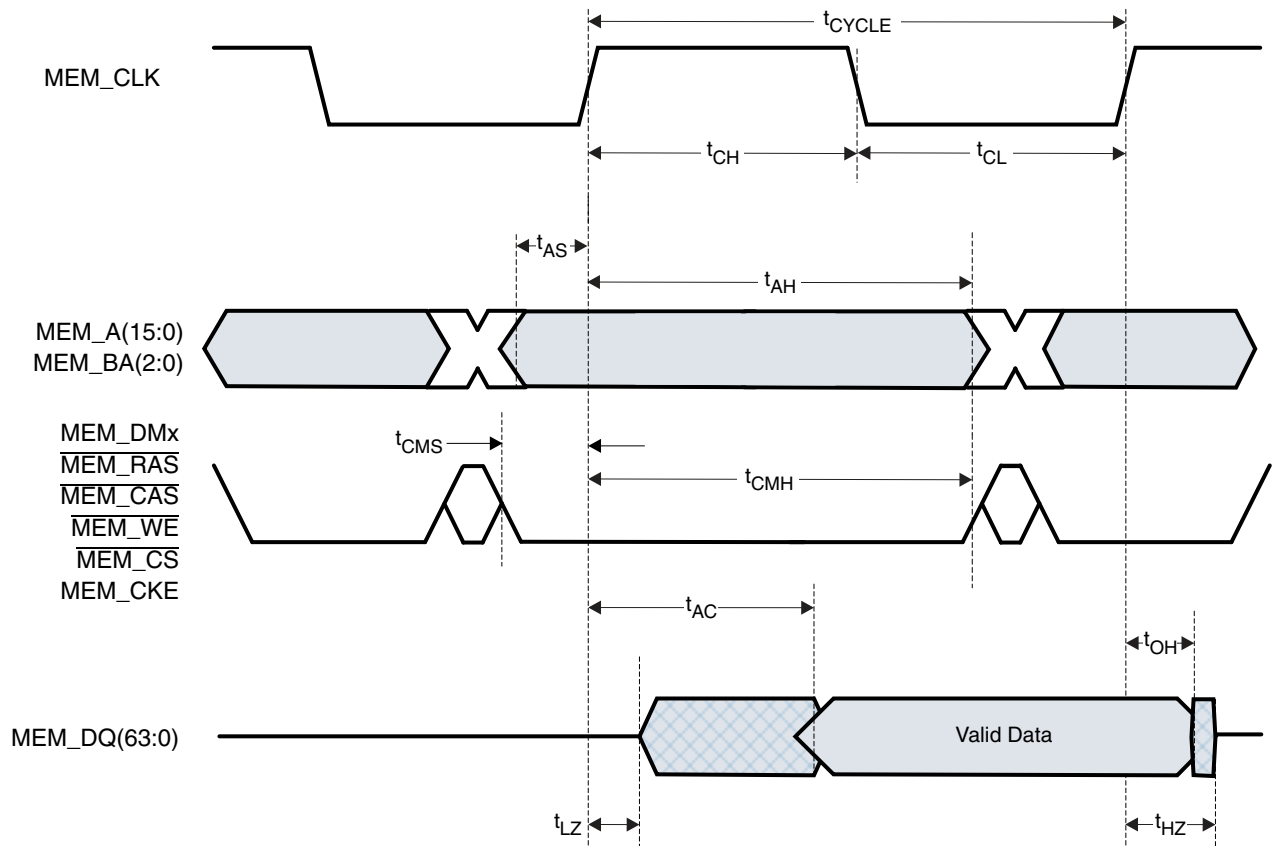

Figure 12. SDR Memory I/F Read Timing

### 6.17 Video Input Pixel Interface – Image Sync and Blanking Requirements

Figure 13 shows how pixels should be mapped to the input data bus for both port 1 and port 2.

PARAMETER		MIN	MAX	UNIT
$t_{p\_vsw}$	Vertical sync duration	1		clocks
$t_{p\_vbp}$	Vertical back porch	14		lines
$t_{p\_vfp}$	Vertical front porch	2		lines
$t_{p\_hsw}$	Horizontal sync duration	1		clocks
$t_{p\_hbp}$	Horizontal back porch	64		clocks
$t_{p\_hfp}$	Horizontal front porch	75		clocks

24-Bit Input Bus, RGB888

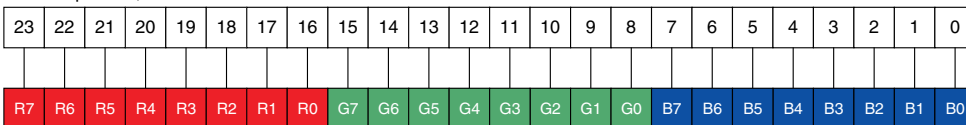

PORTx\_D(23:0) of the Input Pixel Data Bus  
Default Bus Assignment Mapping

RGB888 Format

Figure 13. Pixel Mapping

## 7 Detailed Description

### 7.1 Overview

In DLP-based solutions, image data is 100% digital from the DLPC200 inputs to the image on the DMD. Patterns stay in digital form and are not converted into an analog signal. The DLPC200 controller processes the digital input and converts the data into a format needed by the DMD. The DMD steers light by using binary pulse-duration modulation (PWM) for each micromirror. For further details, refer to DMD data sheet (DLPS013 for the DLP5500 DMD).

The DLPC200 only accepts 1024 × 768 (XGA) formatted data for both video and structured light modes. The functionality of this controller is well-suited for techniques such as structured light, additive manufacturing, or digital exposure.

### 7.2 Functional Block Diagram

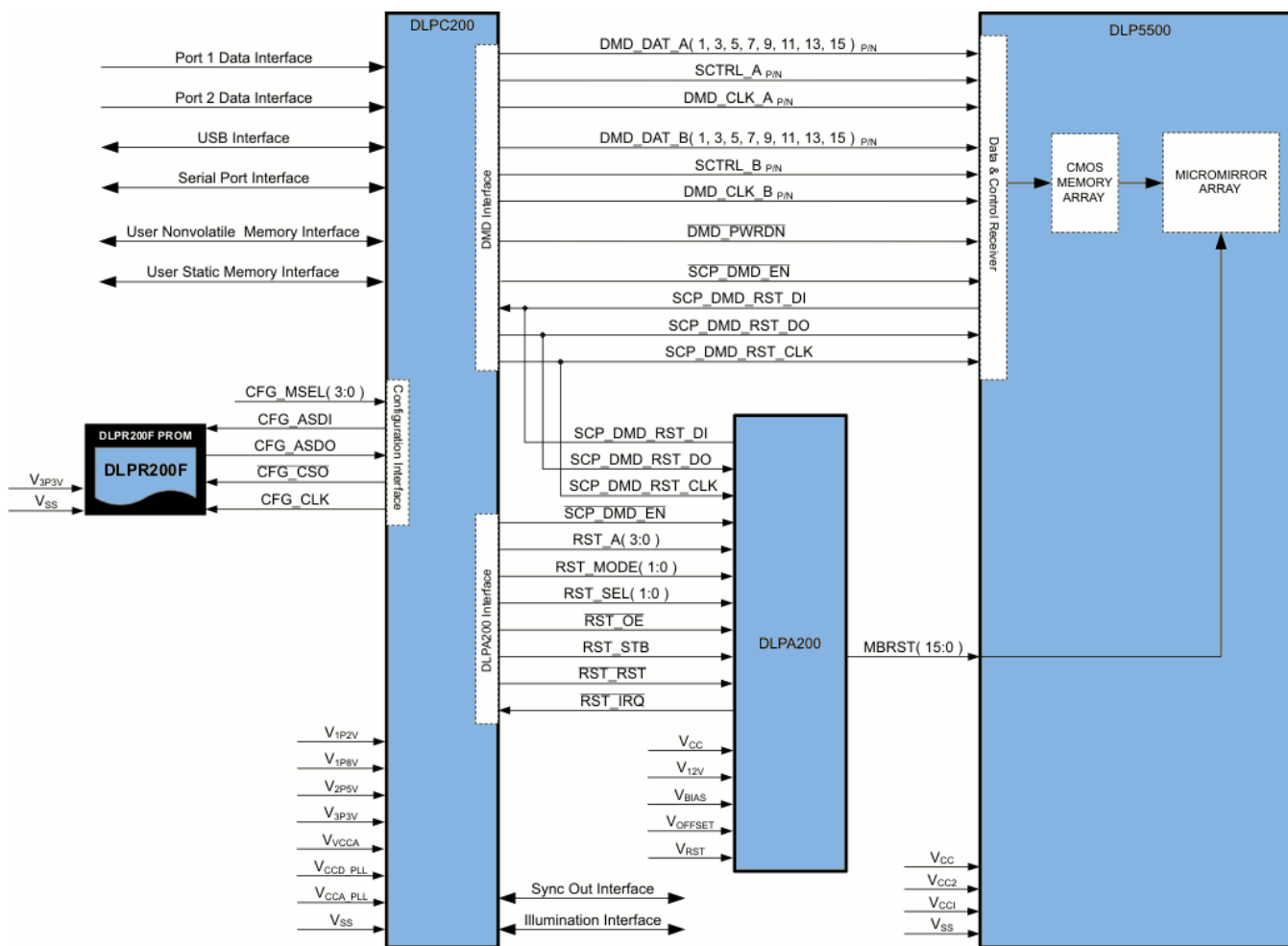

### 7.3 Feature Description

#### 7.3.1 Frame Rates

The digital input interface levels for image data are nominally 1.8 or 3.3 V. Port 1 input is 3.3 V and port 2 input is 1.8 V.

[DLPR200F firmware](#) is provided by TI to support the operation of video and structured light mode.

**Feature Description (continued)**
**Table 1. Frame Rates**

MODE		MIN	MAX	UNIT
Structured light	1 bit per pixel	6	5000	Hz
	8 bits per pixel	6	700	
Video		6	60	Hz

**7.4 Device Functional Modes**

The DLPC200 has two basic functional mode types: video and structured light.

**7.4.1 Video Modes**

The controller accepts RGB-8-8-8 input to port 1 or port 2 through a selectable MUX. XGA video information is displayed on the DMD at 6 to 60 fps.

An internal pattern generator can generate RGB-8-8-8 video patterns into an internal selectable MUX for verification and debug purposes.

**7.4.2 Structured Light Modes**

The DLPC200 provides two structured light modes: static image buffer and real-time structured light.

**7.4.2.1 Static Image Buffer Mode**

Image data can be loaded into parallel flash memory to load to DDR2 memory at startup to be displayed, or can be loaded over USB or the SPI port directly to DDR2 memory to be displayed. Binary (1-bit) or grayscale (8-bit) patterns can be displayed. The memory will hold 960 binary patterns or 120 grayscale patterns.

**7.4.2.2 Real Time Structured Light Mode**

RGB-8-8-8 60 fps data can be input into port 1 or port 2 and reinterpreted as up to 24 binary (1-bit) patterns or three grayscale (8-bit) patterns. The specified number of patterns is displayed equally during the exposure time specified. Any unused RGB-8-8-8 data in the video frame must be filled with data, usually 0s.

For example, during one video frame (16.67 ms), 12 binary patterns of the 24 RGB bits are requested to be displayed during half of the video frame time (exposure time = 8.33 ms). Each of the eight red bits and the four most significant green bits are displayed as a binary pattern for 694  $\mu$ s each. The remaining bits are ignored and the remaining 8.33 ms of the frame will be dark.

## 8 Application and Implementation

### 8.1 Application Information

The DLPC200 is used in conjunction with the DLPA200 driver to drive the DLP5500 (0.55-inch XGA DMD). This combination can be used for a number of applications from 3D printers to microscopes.

The most common application is for 3D structured light measurement applications. In this application, patterns (binary, grayscale, or even full color) are projected onto the target and the distortion of the patterns are recorded by an imaging device to extract 3D (x, y, z) surface information.

### 8.2 Typical Application

A schematic is shown in [Figure 14](#) for projecting RGB and IR structured light patterns onto a measurement target. Typically, an imaging device is triggered through one of the three syncs to record the data as each pattern is displayed.

**Typical Application (continued)**

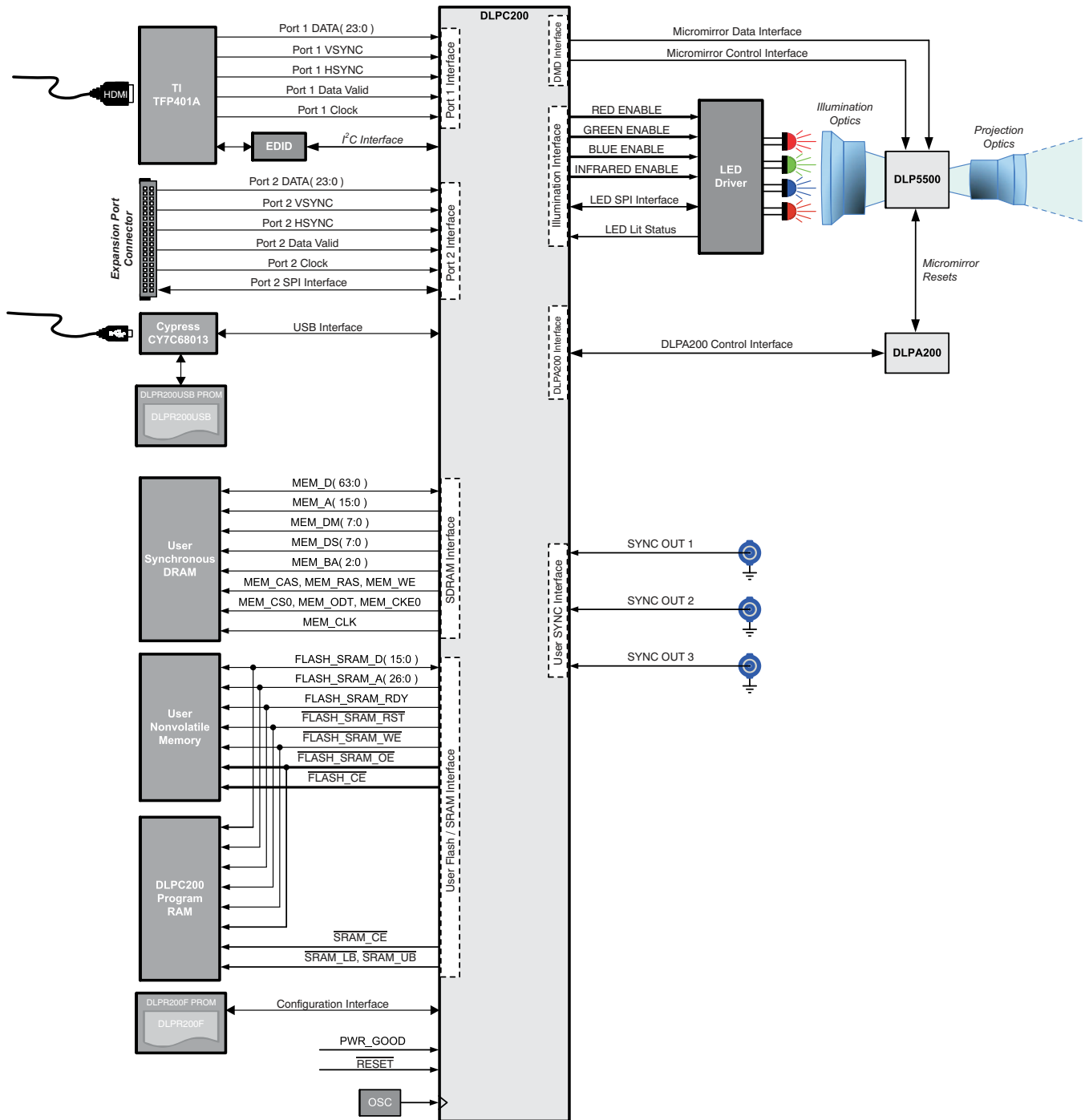

**Figure 14. Typical RGB + IR Structured Light Application**

**8.2.1 Design Requirements**

All applications using the DLP 0.55-inch XGA chipset require the DLPC200 controller, the DLPA200 driver, and the DLP5500 DMD for correct operation. The system also requires user supplied SRAM and a configuration PROM programmed with the DLPR200F program file and a 50-MHz oscillator is for operation.

## Typical Application (continued)

### 8.2.2 Detailed Design Procedure

#### 8.2.2.1 DLPC200 System Interfaces

The DLPC200 supports the following interfaces: extended display identification data (EDID), USB, SPI, parallel flash, serial flash, DDR2 SDRAM, and two RGB888 input ports, which are described in the following subsections.

##### 8.2.2.1.1 DLPC200 Master, I<sup>2</sup>C Interface for EDID Programming

The DLPC200 controller I<sup>2</sup>C interface is only used to program the HDMI EDID. Upon plugging in an HDMI source, the DMD resolution is compared to the HDMI output resolution programmed in the HDMI EDID PROM. If the two resolutions do not match, then the HDMI EDID is adjusted to match the DMD resolution.

The bidirectional I<sup>2</sup>C bus consists of the serial clock (SCL) and serial data (SDA) lines. Both lines must be connected to a positive supply through a pullup resistor when connected to the output stages of a device. Data transfer may be initiated only when the bus is not busy.

I<sup>2</sup>C communication with this device is initiated by a master sending a Start condition, a high-to-low transition on the SDA input/output while the SCL input is high. After the Start condition, the device address byte is sent, MSB first, including the data direction bit (R/W).

After receiving the valid address byte, this device responds with an ACK, a low on the SDA input/output during the high of the ACK-related clock pulse.

On the I<sup>2</sup>C bus, only one data bit is transferred during each clock pulse. The data on the SDA line must remain stable during the high pulse of the clock period, as changes in the data line at this time are interpreted as control commands (Start or Stop). A Stop condition (a low-to-high transition on the SDA input/output while the SCL input is high) is sent by the master.

Any number of data bytes can be transferred from the transmitter to the receiver between the Start and Stop conditions. Each byte of eight bits is followed by one ACK bit. The transmitter must release the SDA line before the receiver can send an ACK bit. The device that acknowledges must pull down the SDA line during the ACK clock pulse so that the SDA line is stable low during the high pulse of the ACK-related clock period. Setup and hold times must be met to ensure proper operation.

**Table 2. Recommended EDID PROM Devices**

PART NUMBER	MANUFACTURER
24LC02B	Microchip Technology

##### 8.2.2.1.2 USB Interface

The USB interface consists of a single-chip integrated USB 2.0 transceiver, smart SIE, and enhanced 8051 microprocessor running at 48 MHz (nominal) that supports USB 2.0.

##### 8.2.2.1.3 Bus Protocol

USB is a polled bus. The host controller (typically at PC) initiates all data transfers. Each transaction begins when the PC sends a packet. Communications are always through the bulk transfer mode, and 512 bytes of data are always written/read at a time. The packet consists of the following:

- Header (6 bytes)
- Data (505 bytes)
- Checksum (1 byte)

The USB device that is addressed selects itself by decoding the appropriate address fields. The direction of data transfer, either read or write, is specified in the packet header. The source of the transaction then sends a data packet or indicates it has no data to transfer. At the end of either a single packet transfer or a multi-packet transfer, the destination responds with a handshake packet indicating whether the transfer was successful.

The packet header consists of:

- CMD1 – Indicates if packet is write/write response or read/read response
- CMD2 – Groups major functions together
- CMD3 – Provides more information about packet grouping defined in CMD2

- CMD4 – Used to indicate location of data in a multi-packet transfer
- Len\_MSB:Len\_LSB – Valid number of bytes of data transferred in packet data

Header						Data	Checksum
CMD1 1 byte	CMD2 1 byte	CMD3 1 byte	CMD4 1 byte	Len_LSB 1 byte	Len_MSB 1 byte	0-505 bytes	1 byte

**Figure 15. USB Data Packet**

As discussed previously, the header describes whether the data transaction is to be a read or write and designates the data endpoint. The data portion of the packet carries the payload and is followed by a handshaking mechanism, checksum, that reports if the data was received successfully, or if the endpoint is stalled or not available to accept data.

**Table 3. Recommended USB Devices**

PART NUMBER	MANUFACTURER
CY7C68013A	Cypress
24LC128I/SN	Microchip Technology

#### 8.2.2.1.4 SPI Slave Interface

The DLPC200 controller SPI interface consists of a 5-MHz input.

The SPI bus specifies five logic signals.

- SLAVE\_SPI\_CLK – Serial clock (output from master)
- SLAVE\_SPI\_MOSI – Master output, slave input (output from master)
- SLAVE\_SPI\_MISO – Master input, slave output (output from slave, does not tristate)
- $\overline{\text{SLAVE\_SPI\_CS}}$  – Slave select (active low; output from master)
- SLAVE\_SPI\_ACK – Holdoff signal to indicate that the slave is processing commands and cannot accept new input (output from slave)

The master pulls the slave-select low. During each SPI clock cycle, a full-duplex data transmission occurs:

- The master sends a bit on the MOSI line; the slave reads it from that same line.
- The slave sends a bit on the MISO line; the master reads it from that same line.

Transmissions involve two shift registers, one in the master and one in the slave; they are connected in a ring. Data is shifted out with the most significant bit first, while shifting a new least significant bit into the same register.

After that register has been shifted out, the master and slave have exchanged register values. If there is more data to exchange, the shift registers are loaded with new data and the process repeats. Transmissions may involve any number of clock cycles.

When there is no more data to be transmitted, the master stops toggling its clock. Transmissions consist of packet commands/responses similar to the protocol defined for the USB interface. The SPI slave supports variable-length command and response packets, and a master can initiate multiple such transmissions as needed.

#### NOTE

The SLAVE\_SPI\_MOSI signal does not tristate. To use the controller's slave SPI interface in a multi-slave SPI bus an external tristate buffer, like [SN74LVC1G125](#), must be used on the SLAVE\_SPI\_MOSI signal.

#### 8.2.2.1.5 Parallel Flash Memory Interface

The controller parallel flash memory interface supports a high-speed NOR device with a 16-bit data bus and up to 1 GB of memory.



To perform an asynchronous read, an address is driven onto the address bus, and  $\overline{CE}$  is asserted.  $\overline{WE}$  and  $\overline{RST}$  must already have been deasserted. WAIT is configured to be active low and is set to a deasserted state.  $\overline{ADV}$  must be held low throughout the read cycle. CLK is not used for asynchronous reads and is ignored. After  $\overline{OE}$  is asserted, the data is driven onto DQ[15:0] after an initial access time  $t_{AVQV}$  or  $t_{GLQV}$  delay.

The WAIT signal indicates data valid when the device is operating in asynchronous mode (RCR.15 = 0). The WAIT signal is only deasserted when data is valid on the bus. When the device is operating in asynchronous non-array read mode, such as read status, read ID, or read query, the WAIT signal is also deasserted when data is valid on the bus. WAIT behavior during asynchronous non-array reads at the end of the word line works correctly only on the first data access.

To perform a write operation, both  $\overline{CE}$  and  $\overline{WE}$  are asserted while  $\overline{RST}$  and  $\overline{OE}$  are deasserted. During a write operation, address and data are latched on the rising edge of  $\overline{WE}$  or  $\overline{CE}$ , whichever occurs first. When the device is operating in write operations, WAIT is set to a deasserted state as determined by RCR.10.

**Table 4. Recommended Parallel Flash Devices**

PART NUMBER	STATUS	MANUFACTURER	SIZE
JS28F00AP30BF	End of Life	Micron (formerly Numonyx)	1 Gb

#### 8.2.2.1.6 Serial Flash Memory Interface

Table 5 shows the serial flash parts that have been tested by TI and found to work properly with the DLPC200.

#### NOTE

The 64 Mb devices originally tested to work with the DLPC200 are now obsolete.

Active devices currently available are only 128 Mb and require a firmware build targeting a 128 Mb part or they will not configure and run the DLPC200.

Devices tested to work with the DLPC200 are listed in Table 5.

Programming file builds for the latest firmware version targeting 64 Mb parts (for backward compatibility with older serial flash devices) and 128 Mb parts (for currently active serial flash devices) are provided on ti.com under [DLPC200 Configuration and Support Firmware](#).

**Table 5. Recommended Serial Flash Devices**

PART NUMBER	STATUS	MANUFACTURER	SIZE
M25P64	Obsolete	Micron (formerly Numonyx)	64 Mb
W25X64	Obsolete	Winbond	64 Mb
MT25QL128AB	Active	Micron	128 Mb
MX25L12835F [Requires firmware rev 2.3.1 or greater]	Active	Macronix	128 Mb

#### 8.2.2.1.7 SRAM Interface

Table 6 shows the Static RAM devices that were tested by TI and found to work properly with the DLPC200. See the recommended SRAM data sheet for read and write cycle timing information.

**Table 6. Recommended Static RAM Devices**

PART NUMBER	STATUS	MANUFACTURER	SIZE
CY7C1011DV33	Active	Cypress	2 Mb

### 8.2.2.1.8 DDR2 SDR Memory Interface

The DDR2 SDRAM is a high-speed CMOS, static dynamic random-access memory. It is internally configured as a multibank DRAM. The controller DDR-2 memory interface consists of four 32-Mb by 16-bit wide, DDR2 interfaces with double-data-rate signaling, operating at 133.33 MHz (nominal). A bidirectional data strobe (DQS,  $\overline{DQS}$ ) is transmitted externally, along with data, for use in data capture at the receiver. DQS is a strobe transmitted by the DDR2 SDRAM during READ commands and by the memory controller during WRITE commands. DQS is edge-aligned with data for READ commands and center-aligned with data for WRITE commands.

The DDR2 SDRAM operates from a differential clock (CK and  $\overline{CK}$ ); the crossing of CK going high and  $\overline{CK}$  going low is referred to as the positive edge of CK. Commands (address and control signals) are registered at every positive edge of CK. Input data is registered on both edges of DQS, and output data is referenced to both edges of DQS as well as to both edges of CK. Read and write accesses to the DDR2 SDRAM are burst-oriented; accesses start at a selected location and continue for a programmed number of locations in a programmed sequence.

Accesses begin with the registration of an ACTIVATE command, which is then followed by a READ or WRITE command. The address bits registered coincident with the ACTIVATE command are used to select the bank and row to be accessed. The address bits registered coincident with the READ or WRITE command are used to select the bank and the starting column location for the burst access.

### 8.2.2.1.9 Projector Image and Control Port Signals

The DLPC200 provides two input ports for graphics and motion video inputs. The following listed signals support the two input interface modes.

Following are the two input image interface modes, signal descriptions, and pins needed on the DLPC200.

- PORT 1, 28 pins (HDMI connector)
  - PORT1\_D(23-0) – Projector data
  - PORT1\_VSYNC – Vertical sync
  - PORT1\_HSYNC – Horizontal sync
  - PORT1\_IVALID – Data enable
  - PORT1\_CLK – Projector clock (rising edge or falling edge, to capture input data)
- PORT 2, 28 pins (expansion connector)
  - PORT2\_D(23-0) – Projector data
  - PORT2\_VSYNC – Vertical sync
  - PORT2\_HSYNC – Horizontal sync
  - PORT2\_IVALID – Data enable
  - PORT2\_CLK – Projector clock (rising edge or falling edge, to capture input data)

Two control interfaces, USB and SPI, are provided to configure the DLPC200, as well as to transmit pattern data to memory for structured light mode. Following are the pins needed for the SPI and USB control interfaces.

- USB, 48 MHz
  - USB\_CLK – USB clock
  - USB\_CTRL1 – FIFO full flag
  - USB\_CTRL2 – FIFO empty flag
  - USB\_FD(15-0) – USB data
  - USB\_PA02 – FIFO output enable for reads
  - USB\_PA04 – FIFO address bit
  - USB\_PA05 – FIFO address bit
  - USB\_RDY1 – Write enable
  - USB\_RDY0 – Read enable
- SPI, 5 MHz
  - SLAVE\_SPI\_CLK – SPI clock
  - SLAVE\_SPI\_ACK – Busy signal that holds off additional transactions until the slave has completed processing data

- SLAVE\_SPI\_MISO – Output from slave
- SLAVE\_SPI\_MOSI – Output from master
- SLAVE\_SPI\_CS – Slave select

Images are displayed via control of the DMD and DLPA200. The DLPC200 DMD interface consists of a 200-MHz (nominal) half-bus DDR output-only interface with LVDS signaling. The serial communications port (SCP), 125-kHz nominal, is used to read or write control data to both the DMD and the DLPA200. The following listed signals support data transfer to the DMD and DLPA200.

- DMD, 200 MHz
  - DMD\_CLK\_AP, DMD\_CLK\_AN – DMD clock for A
  - DMD\_CLK\_BP, DMD\_CLK\_BN – DMD clock for B
  - DMD\_DAT\_AP, DMD\_DAT\_AN(1, 3, 5, 7, 9, 11, 13, 15) – Data bus A (odd-numbered pins are used for half-bus)
  - DMD\_DAT\_BP, DMD\_DAT\_BN(1, 3, 5, 7, 9, 11, 13, 15) – Data bus B (odd-numbered pins are used for half-bus)
  - DMD\_SCRTL\_AP, DMD\_SCRTL\_AN – S-control for A
  - DMD\_SCRTL\_BP, DMD\_SCRTL\_BN – S-control for B
- DLPA200, 125 kHz
  - SCP\_DMD\_RST\_CLK – SCP clock
  - SCP\_DMD\_EN – Enable DMD communication
  - SCP\_RST\_EN – Enable DLPA200 communication
  - SCP\_DMD\_RST\_DI – Input data
  - SCP\_DMD\_RST\_DO – Output data

#### 8.2.2.1.10 SDRAM Memory

The DLPC200 requires an external DDR2 SDRAM. The DLPC200 supports the use of four 512-Mb SDRAMs. The requirements for the SDRAMs are:

- SDRAM type: DDR2
- Speed: 133 MHz minimum
- 16-bit interface size: 32 Mb
- Supply voltage: 1.8 V

[Table 7](#) lists the recommended SDRAM devices that have been tested by TI and found to work properly with the DLPC200.

**Table 7. Recommended SDRAM Devices**

PART NUMBER	STATUS	MANUFACTURER	SIZE
MT47H32M16R	Obsolete	Micron	512 Mb
MT47H32M16-25E	Active	Micron	512 Mb

#### 8.2.3 Application Curve

The DLPC200 is used to control the DLP5500 0.5-inch XGA DMD. This device can be used for numerous applications in the visible range of the spectrum such as 3D printing or structured light. [Figure 16](#) shows single-pass window transmission for 0° and 30° angles of incidence. The area from 420 to 700 nm (light blue) is the range specified for operation of the DLP5500.

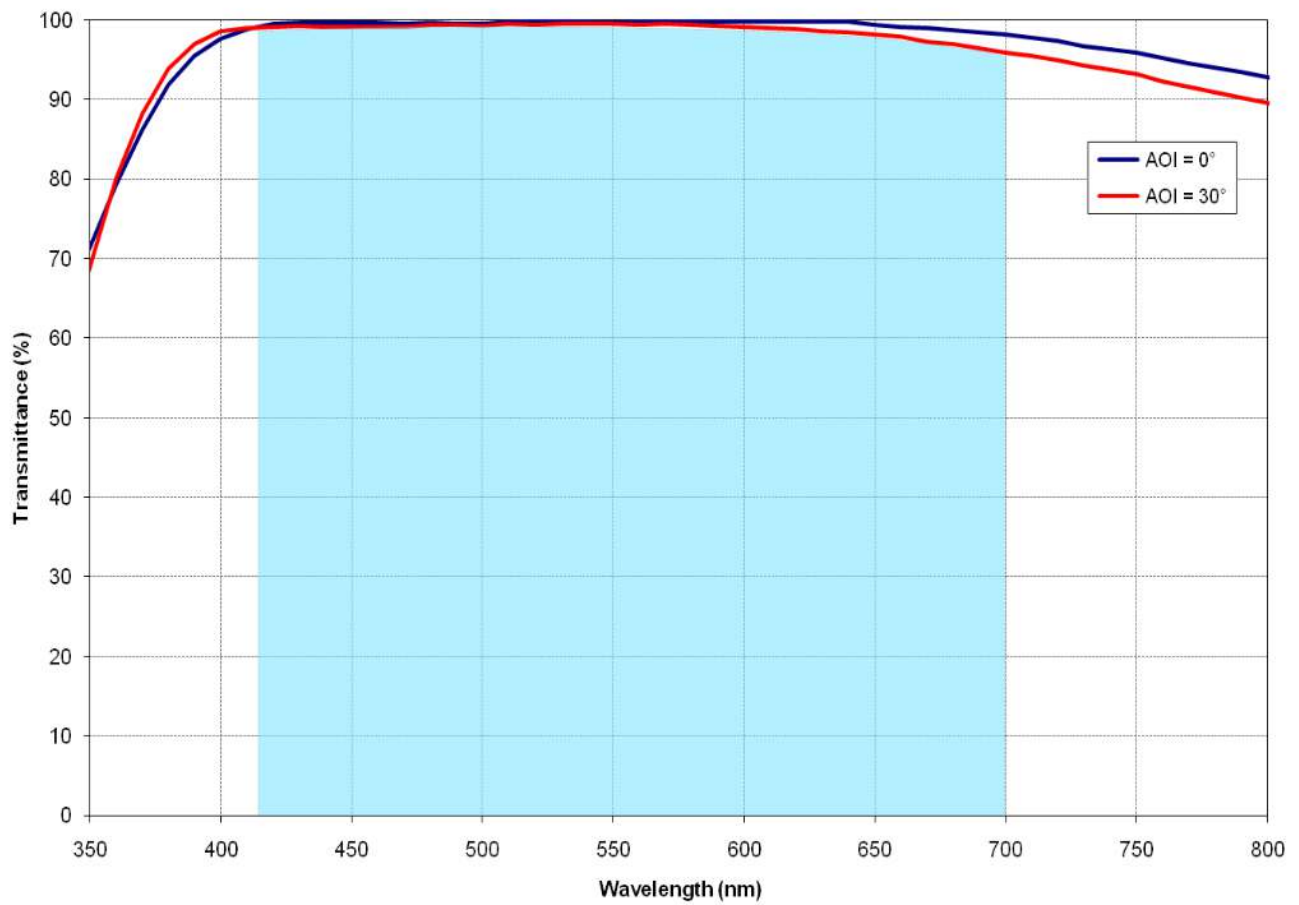

**Figure 16. Window Transmission Curve for the DLP5500**

## 9 Power Supply Recommendations

### 9.1 Power-Up Requirements

Details about the chip power-up requirements are included in the [DLPZ004](#) chipset data sheet. For the DLPC200, there is a 50-MHz reference clock that must meet the specifications listed in [Table 8](#). Additionally, at power-up, the 3.3-V supply must be stable for 2 s before the global reset (RESET) occurs, and then PWR\_GOOD occurs within 20 ms.

The latest revision of the firmware (#DLPR200) does not enable the LEDs over the LED Control interface until initialization is complete and any solution loaded in flash is running.

**Table 8. Reference Clock Oscillator Requirements**

PART NUMBER	FREQUENCY STABILITY	FREQUENCY	SUPPLY VOLTAGE
ASV-50.000MHZ-E-J-T	±20 ppm (0.002% or ±0.001 MHz)	50 MHz	3.3 V

### 9.2 Power-Down Requirements

Details about the chip power-down requirements are included in the [DLPZ004](#) chipset data sheet. For the DLPC200, there is a minimum 1-ms delay from the time when PWR\_GOOD goes low until any of the supplied voltages can drop below their minimum valid values (see [Table 9](#)). This is required so that the DMD can be parked. See [Table 9](#) for more details.

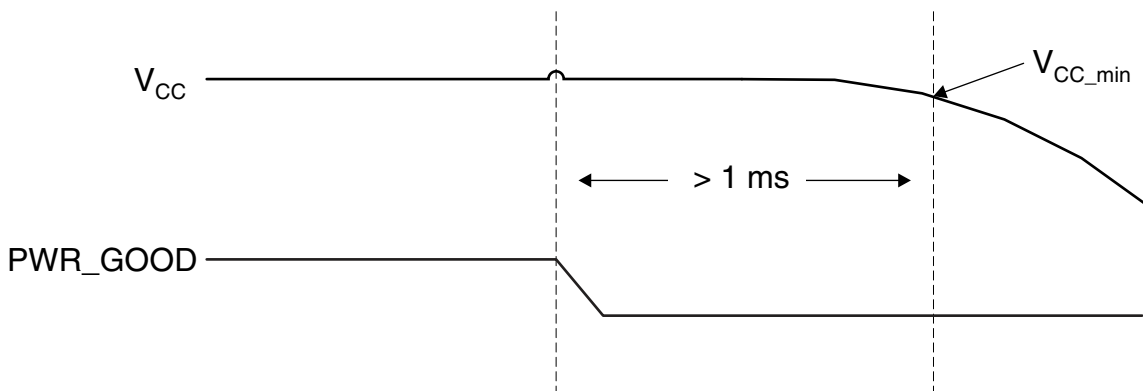

**Figure 17.**

**Table 9. Supply Voltages and Minimum Values**

V <sub>CC</sub>	V <sub>CC_min</sub>	UNIT
1.2	1.14	V
1.8	1.71	
2.5	2.375	
3.3	3.135	

## 10 Layout

### 10.1 Layout Guidelines

#### 10.1.1 Impedance Requirements

Signals should be routed to have a matched impedance of  $50\ \Omega \pm 10\%$  except for LVDS differential pairs (DMD\_DAT\_Xnn, DMD\_DCKL\_Xn, and DMD\_SCTRL\_Xn) and DDR2 differential clock pairs (MEM\_CLK\_nn), which should be matched to  $100\ \Omega \pm 10\%$  across each pair.

#### 10.1.2 PCB Signal Routing

When designing a PCB board for the DLPC200 the following are recommended:

Maintain signal trace corners no sharper than  $45^\circ$ . Adjacent signal layers should have the predominate traces routed orthogonal to each other. TI recommends that critical signals be hand routed in the following order: DDR2 Memory, DMD (LVDS signals), then DLPA200 signals.

TI does not recommend signal routing on power or ground planes.

TI does not recommend ground plane slots.

Do not allow high speed signal traces to cross over slots in adjacent power and/or ground planes.

**Table 10. Important Signal Trace Constraints**

Signal	Constraints
DDR2 differential clock pairs	P-to-N length <12 mils (0.31 mm) Trace width: 30 mil (0.76 mm)
DDR2 data	Length within $\pm 150$ mils (3.81 mm) relative to DDR2 differential clock Maximum termination signal recommended trace length <0.5 inch (12.7 mm)
LVDS (DMD_DAT_xnn, DMD_DCKL_xn, and DMD_SCTRL_xn)	P-to-N data, clock, and SCTRL: <10 mils (0.25 mm); Pair-to-pair <10 mils (0.25 mm); Bundle-to-bundle <2000 mils (50 mm, for example DMD_DAT_Ann to DMD_DAT_Bnn) Trace width: 4 mil (0.1 mm) Trace spacing: In ball field – 4 mil (0.11 mm); PCB etch – 14 mil (0.36 mm) Maximum recommended trace length <6 inches (150 mm)

**Table 11. Power Trace Widths and Spacing**

Signal Name	Minimum Trace Width	Minimum Trace Spacing	Layout Requirements
GND	Maximize	5 mil (0.13 mm)	Maximize trace width to connecting pin as a minimum
P3P3V	400 mil (10.2 mm)	10 mil (0.25 mm)	Create mini plane and connect to devices as necessary with multiple vias
P5V, P2P5V, P1P8V, P1P5V, P1P2V	50 mil (1.3 mm)	10 mil (0.25 mm)	Create mini planes and connect to devices as necessary with multiple vias
P5V, P3P3V, P2P5V, P1P8V, P1P5V, P1P2V	30 mil (0.76 mm)	10 mil (0.25 mm)	Stub width to connecting IC pins; maximize width when possible
VREF_Bn	200 mil (5.1 mm)	30 mil (0.76 mm)	Stub width to connecting IC pins; maximize width when possible

#### 10.1.3 Fiducials

For automatic component insertion fiducials, use 0.05-inch copper with a 0.1-inch cutout (antipad). Fiducials for optical auto insertion are placed on three corners of both sides of the PCB.

### 10.2 Layout Example

For LVDS (and other differential signal) pairs and groups, it is important to match trace lengths. In the area of the dashed lines, [Figure 18](#) shows correct matching of signal pair lengths with serpentine sections to maintain the correct impedance.

## Layout Example (continued)

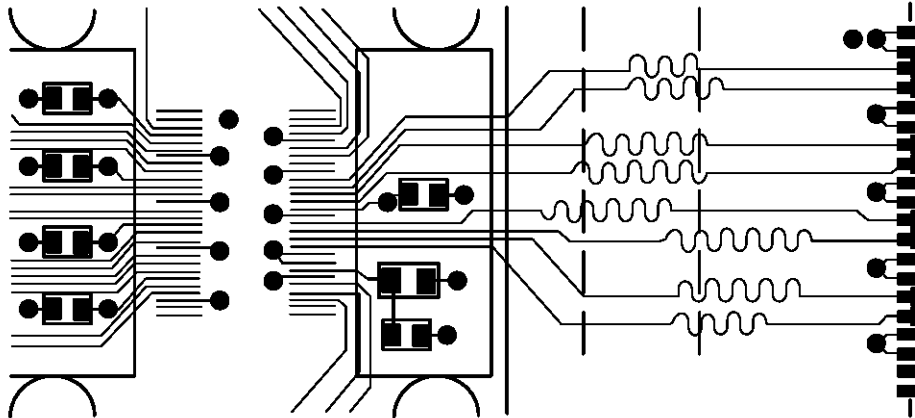

Figure 18. Mitering LVDS Traces to Match Lengths

### 10.3 Thermal Considerations

The underlying thermal limitation for the DLPC200 is that the maximum operating junction temperature ( $T_J$ ) not be exceeded (see [Recommended Operating Conditions](#)). This temperature depends on operating ambient temperature, airflow, PCB design (including the component layout density and the amount of copper used), power dissipation of the DLPC200, and power dissipation of surrounding components. The DLPC200 package is designed primarily to extract heat through the power and ground planes of the PCB; thus, copper content and airflow over the PCB are important factors.

#### 10.3.1 Heat Sink

A heat sink not required for operation between 0°C and 55°C ambient, but is required for operation between 55°C and 85°C, TI recommends a low-profile (15-mm) heat sink. See [Thermal Information](#) for thermal resistance with different airflow values without a heat sink.

## 11 Device and Documentation Support

### 11.1 Device Support

#### 11.1.1 Third-Party Products Disclaimer

TI'S PUBLICATION OF INFORMATION REGARDING THIRD-PARTY PRODUCTS OR SERVICES DOES NOT CONSTITUTE AN ENDORSEMENT REGARDING THE SUITABILITY OF SUCH PRODUCTS OR SERVICES OR A WARRANTY, REPRESENTATION OR ENDORSEMENT OF SUCH PRODUCTS OR SERVICES, EITHER ALONE OR IN COMBINATION WITH ANY TI PRODUCT OR SERVICE.

#### 11.1.2 Device Marking

Device marking should be as shown in the following.



Marking key:

- Line 1: TI reference number
- Line 2: Device name
- Line 3: DLP<sup>®</sup> logo
- Line 4: Date code
- Line 5: Country of origin
- Line 6: Assembly lot number
- Line 7: Trace code

### 11.2 Documentation Support

Related documents:

- [DLP5500 0.55 XGA DMD data sheet](#)
- [DLPA200 DMD micromirror driver](#)
- [DLPC200 API Reference Manual](#)
- [DLPC200 API Programmer's Guide](#)
- [IC Package Thermal Metrics application report](#)

### 11.3 Receiving Notification of Documentation Updates

To receive notification of documentation updates, navigate to the device product folder on ti.com. In the upper right corner, click on *Alert me* to register and receive a weekly digest of any product information that has changed. For change details, review the revision history included in any revised document.



## 11.4 Community Resources

The following links connect to TI community resources. Linked contents are provided "AS IS" by the respective contributors. They do not constitute TI specifications and do not necessarily reflect TI's views; see TI's [Terms of Use](#).

**TI E2E™ Online Community** *TI's Engineer-to-Engineer (E2E) Community*. Created to foster collaboration among engineers. At [e2e.ti.com](http://e2e.ti.com), you can ask questions, share knowledge, explore ideas and help solve problems with fellow engineers.

**Design Support** *TI's Design Support* Quickly find helpful E2E forums along with design support tools and contact information for technical support.

## 11.5 Trademarks

E2E is a trademark of Texas Instruments.  
DLP is a registered trademark of Texas Instruments.

## 11.6 Electrostatic Discharge Caution



These devices have limited built-in ESD protection. The leads should be shorted together or the device placed in conductive foam during storage or handling to prevent electrostatic damage to the MOS gates.

## 11.7 Glossary

[SLYZ022](#) — *TI Glossary*.

This glossary lists and explains terms, acronyms, and definitions.

## 12 Mechanical, Packaging, and Orderable Information

The following pages include mechanical, packaging, and orderable information. This information is the most current data available for the designated devices. This data is subject to change without notice and revision of this document. For browser-based versions of this data sheet, refer to the left-hand navigation.

**PACKAGING INFORMATION**

Orderable Device	Status (1)	Package Type	Package Drawing	Pins	Package Qty	Eco Plan (2)	Lead finish/ Ball material (6)	MSL Peak Temp (3)	Op Temp (°C)	Device Marking (4/5)	Samples
DLPC200ZEW	ACTIVE	BGA	ZEW	780	5	TBD	Call TI	Call TI	-20 to 85		Samples

(1) The marketing status values are defined as follows:

**ACTIVE:** Product device recommended for new designs.

**LIFEBUY:** TI has announced that the device will be discontinued, and a lifetime-buy period is in effect.

**NRND:** Not recommended for new designs. Device is in production to support existing customers, but TI does not recommend using this part in a new design.

**PREVIEW:** Device has been announced but is not in production. Samples may or may not be available.

**OBSELETE:** TI has discontinued the production of the device.

(2) **RoHS:** TI defines "RoHS" to mean semiconductor products that are compliant with the current EU RoHS requirements for all 10 RoHS substances, including the requirement that RoHS substance do not exceed 0.1% by weight in homogeneous materials. Where designed to be soldered at high temperatures, "RoHS" products are suitable for use in specified lead-free processes. TI may reference these types of products as "Pb-Free".

**RoHS Exempt:** TI defines "RoHS Exempt" to mean products that contain lead but are compliant with EU RoHS pursuant to a specific EU RoHS exemption.

**Green:** TI defines "Green" to mean the content of Chlorine (Cl) and Bromine (Br) based flame retardants meet JS709B low halogen requirements of <=1000ppm threshold. Antimony trioxide based flame retardants must also meet the <=1000ppm threshold requirement.

(3) MSL, Peak Temp. - The Moisture Sensitivity Level rating according to the JEDEC industry standard classifications, and peak solder temperature.

(4) There may be additional marking, which relates to the logo, the lot trace code information, or the environmental category on the device.

(5) Multiple Device Markings will be inside parentheses. Only one Device Marking contained in parentheses and separated by a "-" will appear on a device. If a line is indented then it is a continuation of the previous line and the two combined represent the entire Device Marking for that device.

(6) Lead finish/Ball material - Orderable Devices may have multiple material finish options. Finish options are separated by a vertical ruled line. Lead finish/Ball material values may wrap to two lines if the finish value exceeds the maximum column width.

**Important Information and Disclaimer:**The information provided on this page represents TI's knowledge and belief as of the date that it is provided. TI bases its knowledge and belief on information provided by third parties, and makes no representation or warranty as to the accuracy of such information. Efforts are underway to better integrate information from third parties. TI has taken and continues to take reasonable steps to provide representative and accurate information but may not have conducted destructive testing or chemical analysis on incoming materials and chemicals. TI and TI suppliers consider certain information to be proprietary, and thus CAS numbers and other limited information may not be available for release.

In no event shall TI's liability arising out of such information exceed the total purchase price of the TI part(s) at issue in this document sold by TI to Customer on an annual basis.

ZEW (S-PBGA-N780)

PLASTIC BALL GRID ARRAY

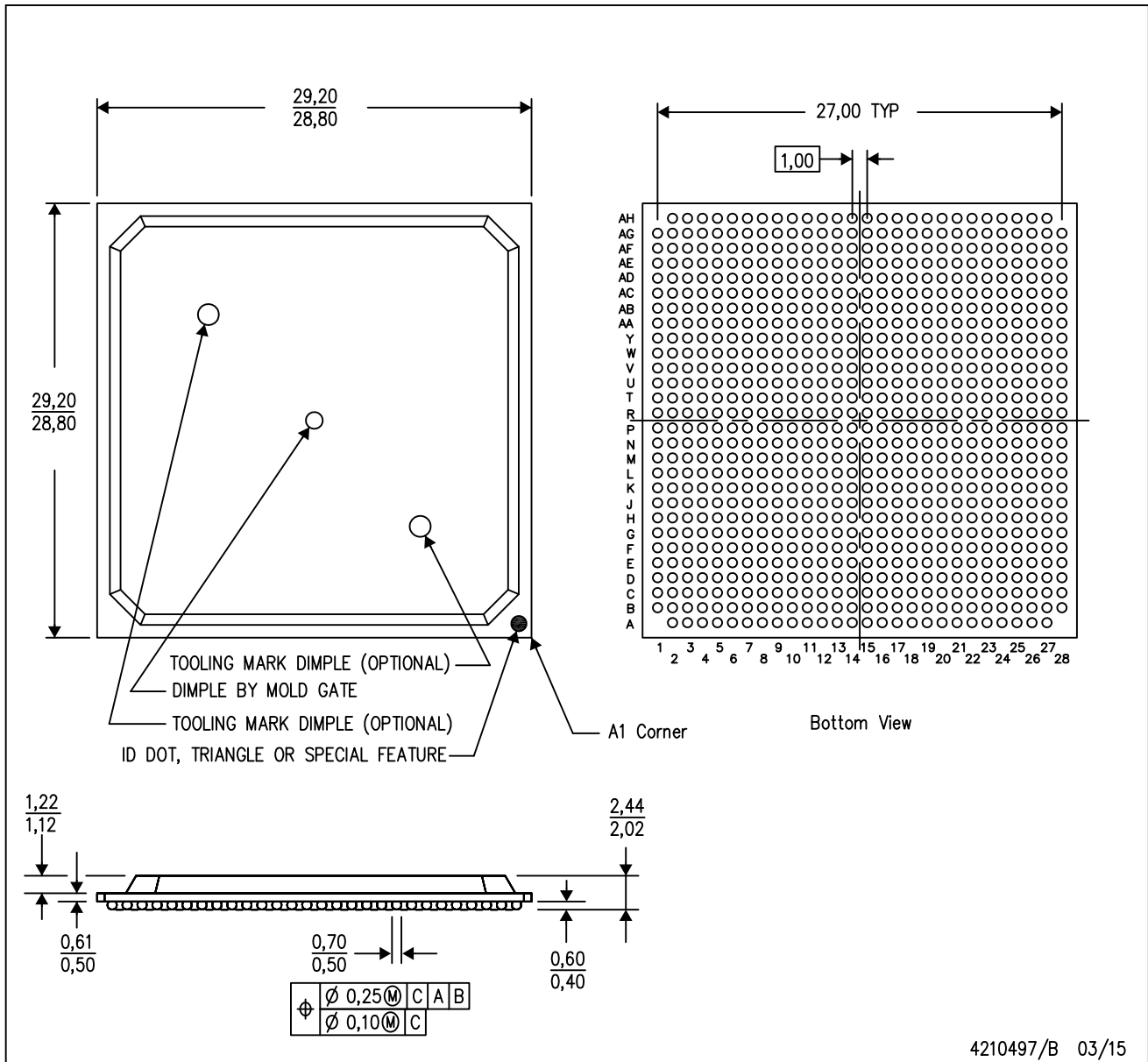

- NOTES:
- A. All linear dimensions are in millimeters. Dimensioning and tolerancing per ASME Y14.5M-1994.
  - B. This drawing is subject to change without notice.
  - C. Falls within JEDEC MS-034, Variation: AAM-1.
  - D. This package is Pb-free.

## IMPORTANT NOTICE AND DISCLAIMER

TI PROVIDES TECHNICAL AND RELIABILITY DATA (INCLUDING DATA SHEETS), DESIGN RESOURCES (INCLUDING REFERENCE DESIGNS), APPLICATION OR OTHER DESIGN ADVICE, WEB TOOLS, SAFETY INFORMATION, AND OTHER RESOURCES "AS IS" AND WITH ALL FAULTS, AND DISCLAIMS ALL WARRANTIES, EXPRESS AND IMPLIED, INCLUDING WITHOUT LIMITATION ANY IMPLIED WARRANTIES OF MERCHANTABILITY, FITNESS FOR A PARTICULAR PURPOSE OR NON-INFRINGEMENT OF THIRD PARTY INTELLECTUAL PROPERTY RIGHTS.

These resources are intended for skilled developers designing with TI products. You are solely responsible for (1) selecting the appropriate TI products for your application, (2) designing, validating and testing your application, and (3) ensuring your application meets applicable standards, and any other safety, security, regulatory or other requirements.

These resources are subject to change without notice. TI grants you permission to use these resources only for development of an application that uses the TI products described in the resource. Other reproduction and display of these resources is prohibited. No license is granted to any other TI intellectual property right or to any third party intellectual property right. TI disclaims responsibility for, and you will fully indemnify TI and its representatives against, any claims, damages, costs, losses, and liabilities arising out of your use of these resources.

TI's products are provided subject to [TI's Terms of Sale](#) or other applicable terms available either on [ti.com](http://ti.com) or provided in conjunction with such TI products. TI's provision of these resources does not expand or otherwise alter TI's applicable warranties or warranty disclaimers for TI products.

TI objects to and rejects any additional or different terms you may have proposed.

Mailing Address: Texas Instruments, Post Office Box 655303, Dallas, Texas 75265  
Copyright © 2022, Texas Instruments Incorporated