

7.0-14V Input 10A Output Point-of-Load Converter



Features

- Input range: 7.0–14V
- Wide output range: 1.2–6V
- Remote enable control, output trim, output over-current/over-temperature/short-circuit protections, monotonic start-up
- Small size: 10.7 mm x 16.8 mm x 9.7 mm (0.42 in x 0.66 in x 0.38 in)
- Wide operating temperature range (-40°C to 85°C)
- All components meet UL 94V0

Applications

- Intermediate bus architecture
- Telecom, datacom, networking equipment
- Electronic data processing, servers
- Distributed power architectures

Part Numbering System

NRT	1	000	P	010	T	0	5
Series Name:	Nominal Input Voltage:	Nominal Output Voltage:	Enabling Logic:	Rated Output Current:	Pin Length Options:	Electrical Options:	Mechanical Options
NRT	1:7.0- 14V	000 = adj (1.2 – 6.0V)	P: positive	Unit: A 010: 10A	T: Through-Hole	0: Standard	Lead-free, (ROHS-6 Compliant) 5: Standard

Standard product has variable output voltage (adjustable between 1.2 – 6V). Please contact the factory if fixed output voltage models are needed.

The above example NRT1000P010T05 denotes a variable voltage, 10A output converter in Pb-free (RoHS compliant) with positive enabling logic.



Absolute Maximum Ratings

Excessive stresses over these absolute maximum ratings can cause damage to the converter. Operation should be limited to the conditions outlined under the Electrical Specification Section.

Parameter	Symbol	Min	Max	Unit
Input Voltage (continuous)	V_i	-0.3	15	Vdc
EN Voltage	V_{EN}	-0.3	6	Vdc
Operating Ambient Temperature (See Thermal Consideration section)	T_o	-40	85*	°C
Storage Temperature	T_{stg}	-55	125	°C

* Derating curves provided in this datasheet end at 85°C ambient temperature. Operation above 85°C ambient temperature is allowed provided the temperatures of the key components do not exceed the limit stated in the Thermal Considerations section.

Electrical Specifications

These specifications are valid over the converter's full range of input voltage, resistive load, and temperature unless noted otherwise.

Input Specifications

Parameter	Symbol	Min	Typical	Max	Unit
Input Voltage	V_i	7.0	-	14	Vdc
Input Current	i_{i_max}	-	-	12	A
Quiescent Input Current ($V_{in} = 12V, V_o = 3.3V$)	i_{i_Qsnt}	-	27.5	-	mA
Standby Input Current	i_{i_stdby}	-	2	-	mA
Input Reflected-ripple Current, Peak-to-peak (5 Hz to 20 MHz, 1 μ H source impedance)	-	-	50	-	mA _{p-p}
Input Ripple Rejection (120 Hz)	-	-	50	-	dB

Output Specifications

Parameter	Symbol	Min	Typical	Max	Unit
Output Voltage Set Point Tolerance ($V_i = 12V; I_o = I_{o_max}; T_a = 25^\circ C$)	-	-1.5	-	1.5	%
Output Voltage Set Point Tolerance (over all conditions)	-	-3.0	-	3.0	%
Output Regulation:					
Line Regulation ($V_i = 7.0V$ to $14V, I_o = 1/2$ of load)	-	-1.5	-	1.5	%
Load Regulation ($I_o = I_{o_min}$ to $I_{o_max}, V_i = 12V$)	-	-	-	50	mV
Temperature ($T_a = -40^\circ C$ to $85^\circ C$)	-	-	-	20	mV
Output Ripple and Noise Voltage (5 Hz to 20 MHz bandwidth, $V_{in} = 12V$)	Peak-to-peak	-	50	-	mV
	RMS	-	20	-	mV
External Load Capacitance	-	47	-	1000	μ F
Output Current	I_o	0	-	10	A
Output Current-limit Trip Point (hiccup mode)	I_{o_cli}	-	13	-	A
Turn-on Time ($I_o =$ full load, V_o from 10% to within 90% of set point)	-	-	5.0	-	ms



Output Specifications (continued)

Parameter	Symbol	Min	Typical	Max	Unit
Efficiency (Vi = 12V; Io = Iomax, TA = 25°C)	Vo = 1.2V	η	86.5		%
	Vo = 1.8V	η	89.0		%
	Vo = 2.5V	η	91.0		%
	Vo = 3.3V	η	92.5		%
	Vo = 5V	η	94.5		%
	Vo = 6V	η	95.0		%
Dynamic Response (Vi = 12V; Ta = 25°C; Load transient 2.5A/μs) Load step from 50% to 0% of full load, Co=47μF					
Peak deviation			100		mV
Settling time (to 10% band of Vo deviation)			20		μs
Load step from 0% to 50% of full load, Co=47μF					
Peak deviation			100		mV
Settling time (to 10% band of Vo deviation)			20		μs

General Specifications

Parameter	Symbol	Min	Typical	Max	Unit
Remote Enable					
Positive Logic:		-			
Logic High – Module On	-		-	-	-
Logic Low – Module Off					
Logic Low:					
VON/OFF = 0.0V	VON/OFF	-0.3	-	0.5	V
ION/OFF = 1mA	ION/OFF	-	-	1	mA
Logic High:					
VON/OFF	VON/OFF	1.5	-	5	V
ION/OFF = 50μA	ION/OFF	-	-	50	μA
Calculated MTBF (Telecordia SR-332, 2011, Issue 3), full load, 40°C, 60% upper confidence level, typical Vin			12.9		10 ⁶ -hour
Switching Frequency	Fsw	350	-	1150	kHz



Characteristic Curves

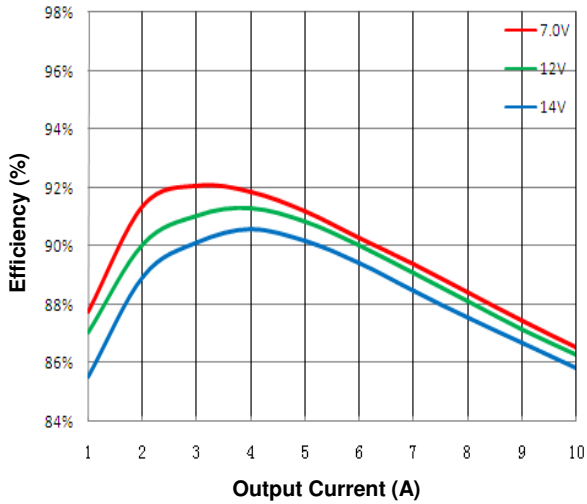

Figure 1(a). Efficiency vs. Load Current (25°C, 1.2V output)

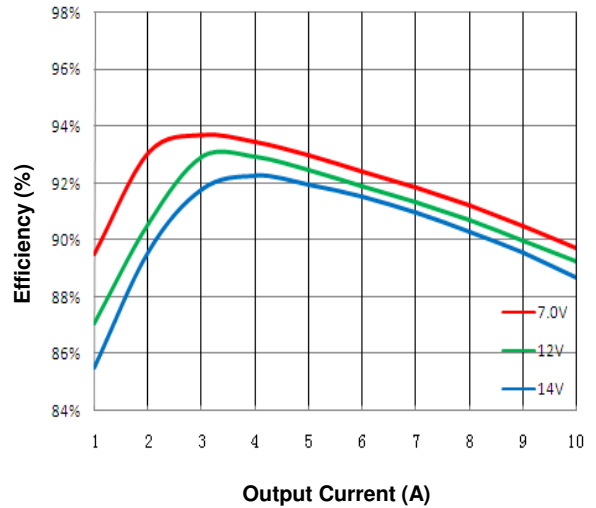

Figure 1(b). Efficiency vs. Load Current (25°C, 1.8V output)

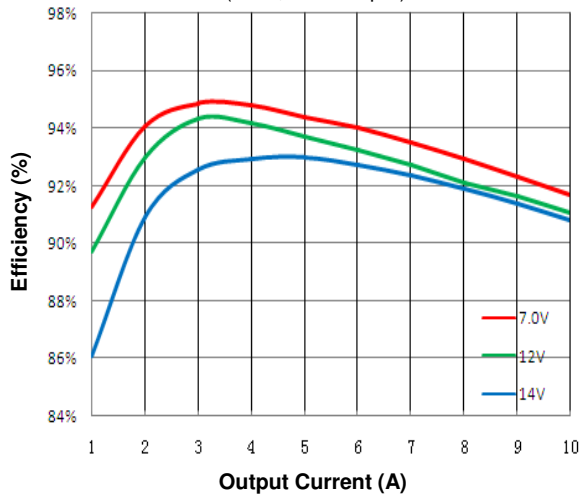

Figure 1(c). Efficiency vs. Load Current (25°C, 2.5V output)

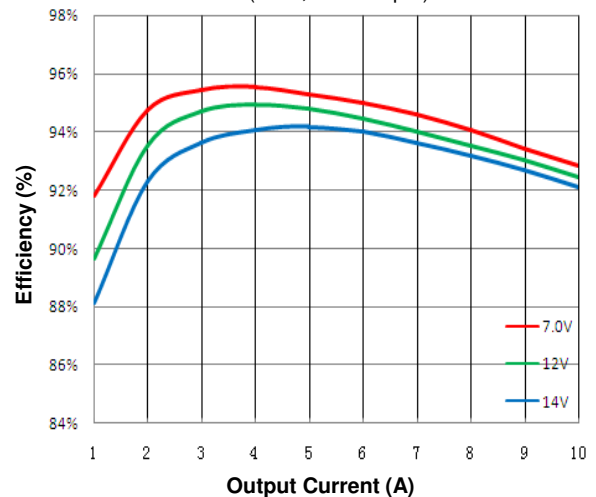

Figure 1(d). Efficiency vs. Load Current (25°C, 3.3V output)

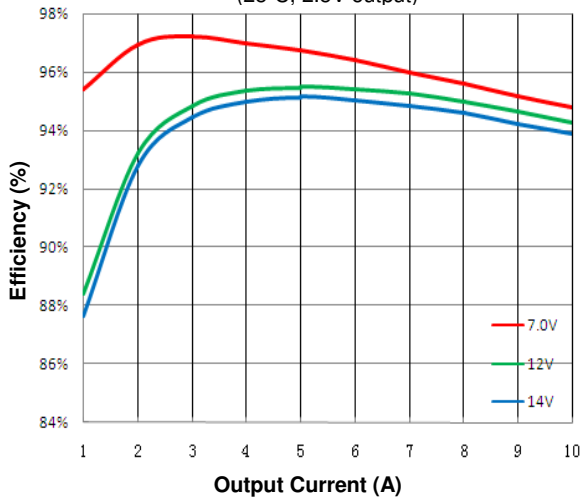

Figure 1(e). Efficiency vs. Load Current (25°C, 5V output)

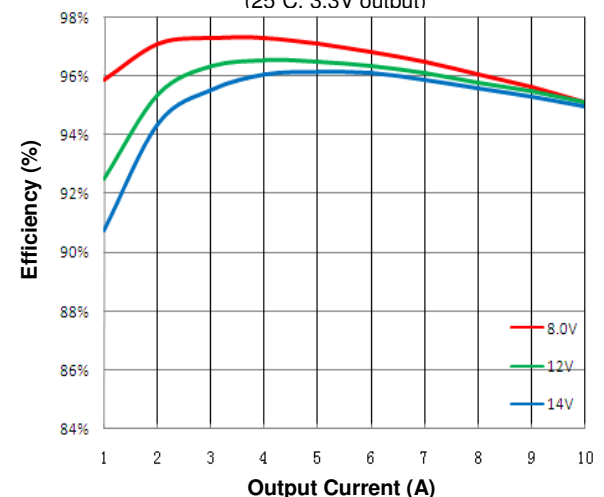
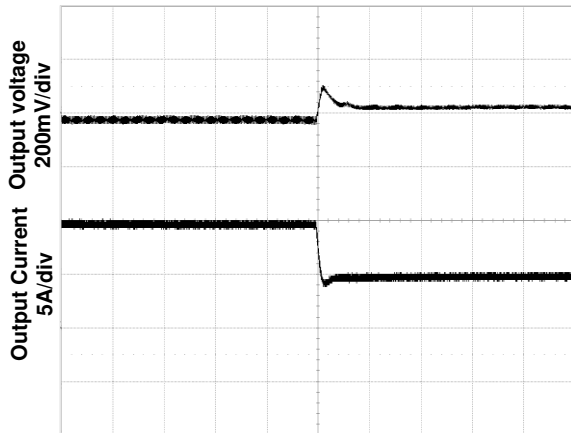
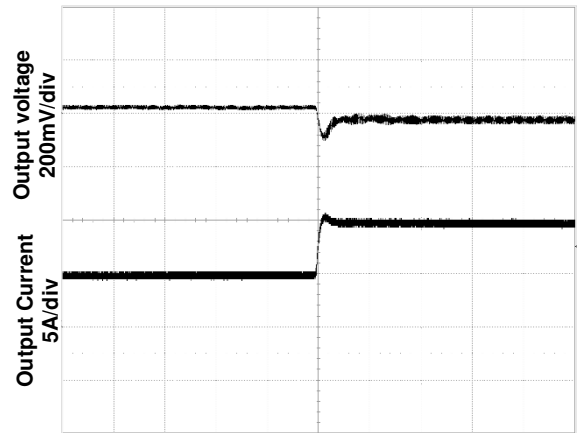

Figure 1(f). Efficiency vs. Load Current (25°C, 6V output)



Time – 50 (us/div)

Figure 2. Transient Load Response
Input voltage 12V, Output voltage 6V, Output current 10A->5A, Slew rate 2.5A/μs



Time – 50 (us/div)

Figure 3. Transient Load Response
Input voltage 12V, Output voltage 6V, Output current 5A->10A, Slew rate 2.5A/μs

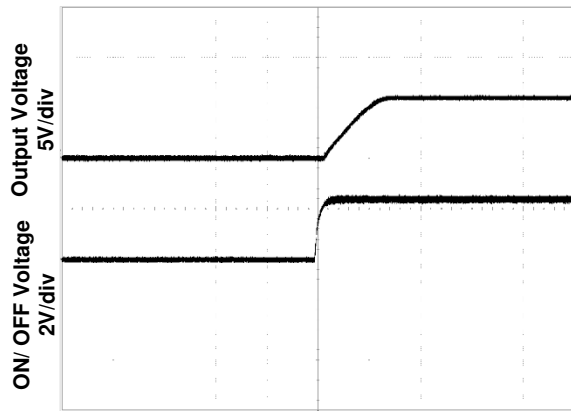

Time – (5ms/div)

Figure 4. Start-Up from ON/ OFF
Input Voltage 12V, Output Current 0A

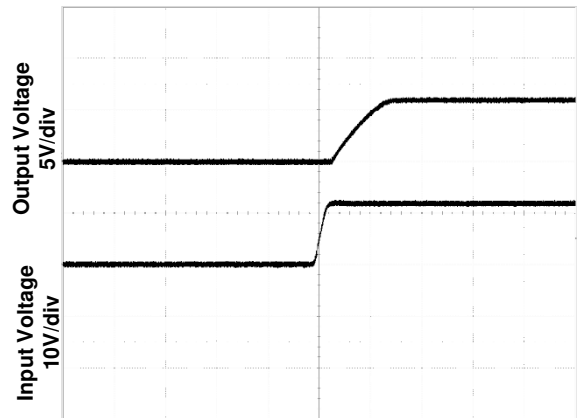

Time – (5ms/div)

Figure 5. Start-Up from Input Voltage
Input Voltage 12V, Output Current 0A

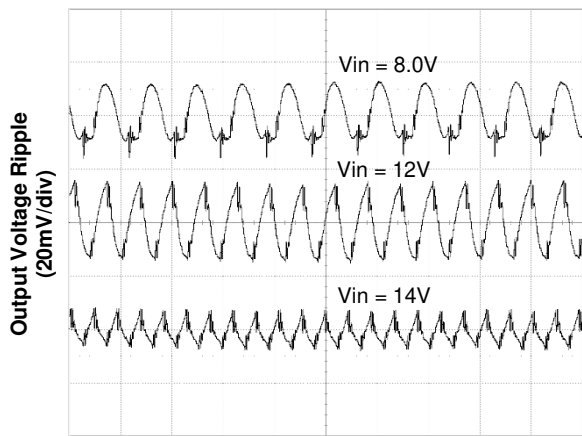

Time – (1μs/div)

Figure 6. Output Ripple Voltage
at Output Voltage 6V, Output Current 10A

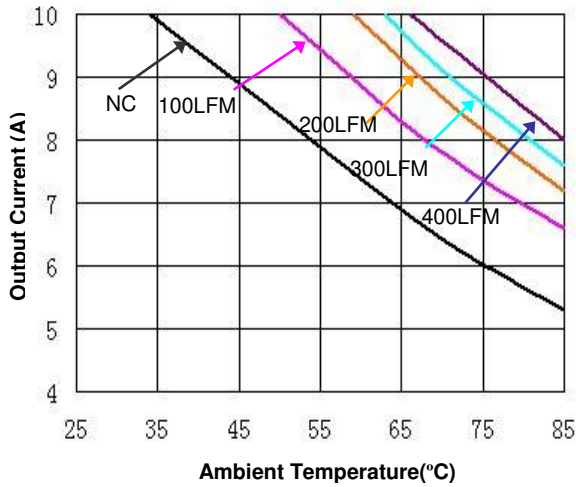

Figure 7 (a). Current Derating Curve for 1.2V Output
 $V_{in} = 12V$, open frame

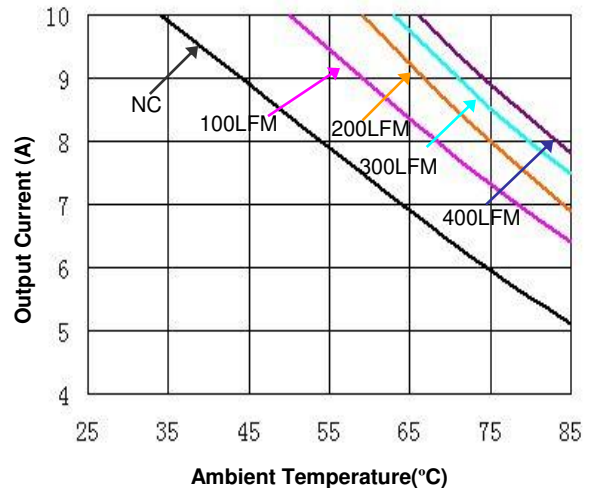

Figure 7 (b). Current Derating Curve for 1.8V Output
 $V_{in} = 12V$, open frame

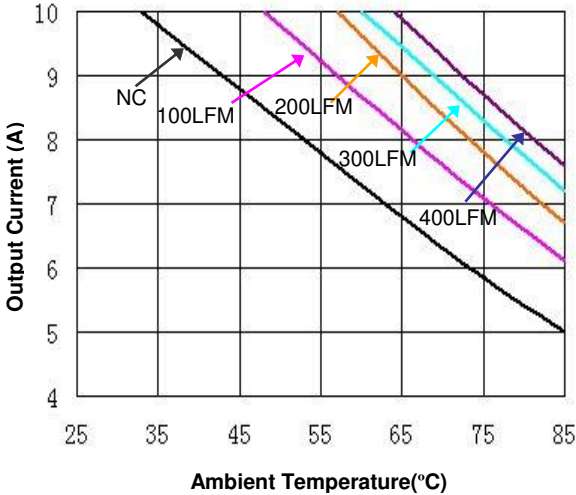

Figure 7 (c). Current Derating Curve for 2.5V Output
 $V_{in} = 12V$, open frame

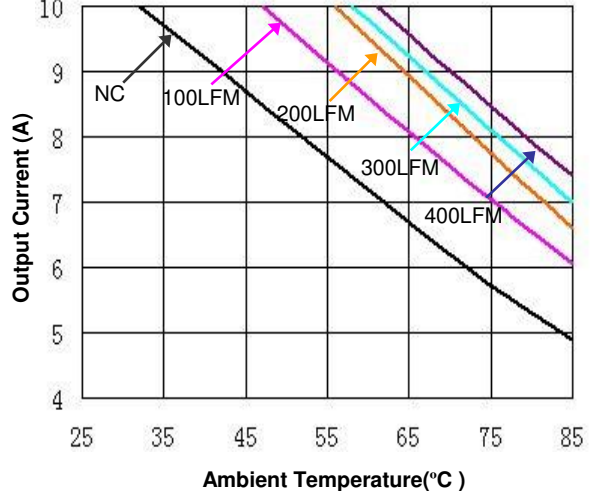

Figure 7 (d). Current Derating Curve for 3.3V Output
 $V_{in} = 12V$, open frame

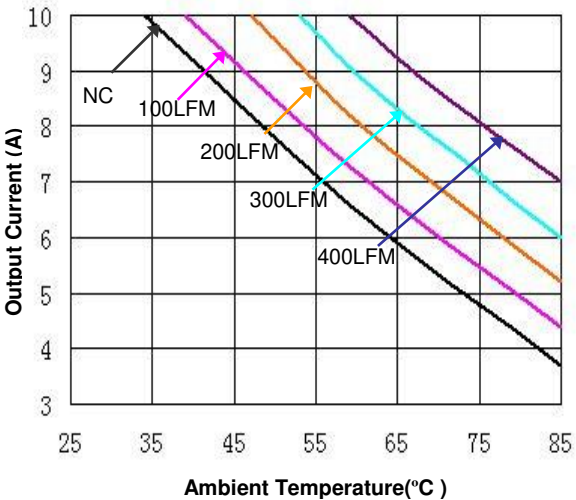

Figure 7 (e). Current Derating Curve for 5.0V Output
 $V_{in} = 12V$, open frame

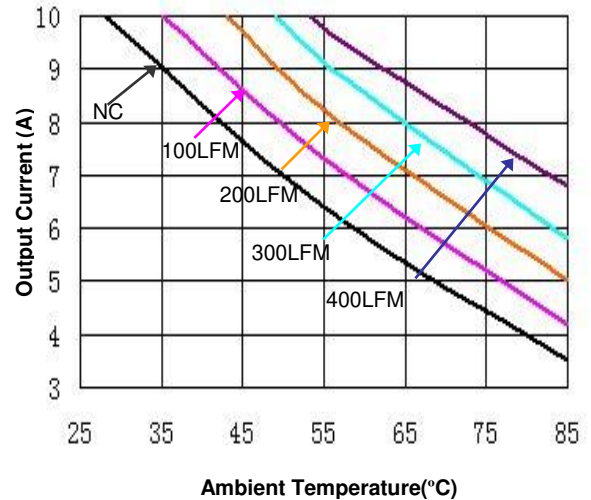

Figure 7 (f). Current Derating Curve for 6.0V Output
 $V_{in} = 12V$, open frame

Feature Descriptions

Remote ON/OFF

The converter can be turned on and off by changing the voltage or resistance between the ON/OFF pin and GND. The NRT converters can be ordered with positive logic .

For the positive control logic, the converter is ON when the ON/OFF pin is at a logic high level and OFF when the ON/OFF pin is at a logic low level. The converter is ON no matter what control logic is when the ON/OFF pin is left open (unconnected).

The maximum allowable leakage current from this pin at logic-high level is listed in the General Specifications table.

Figure 8 is the recommended ON/OFF control circuit for negative logic application.

The logic-low level is from -0.3V to 0.5V, and the maximum sink current during logic low is 1mA. The external switch must be capable of maintaining a logic-low level while sink this current.

Figure 9 shows direct logic control. When this method is used, it's important to make sure that the voltage at the ON/OFF pin is less than 0.5V in logic LOW state, and is not lower than 1.5V in logic HIGH state.

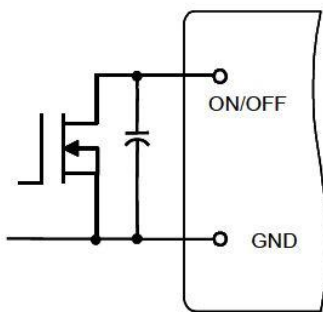

Figure 8. Circuit for Negative Logic Control

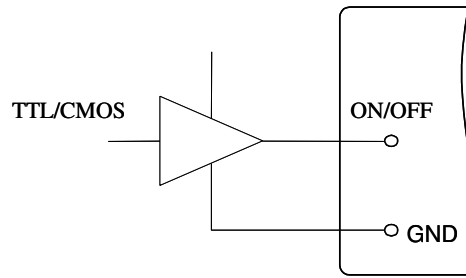

Figure 9. Direct Logic Drive

Output Voltage Programming and Adjustment

This series of converters is available with variable output. The converters are preset to a nominal 1.2V output voltage, and can be trimmed up to 6.0V using an external trim resistor. With a trim resistor, the output voltage can only be adjusted higher than the nominal output voltage.

The trim pin allows the user to adjust the output voltage set point with an external resistor or voltage. To increase the output voltage, a resistor should be connected between the TRIM pin and the GND pin as shown in Figure 10. The value of the external resistor is governed by the equation below:

$$R_{trim} = \frac{27.6}{V_o - 1.2} (k\Omega)$$

Where V_o is the desired output voltage set point.

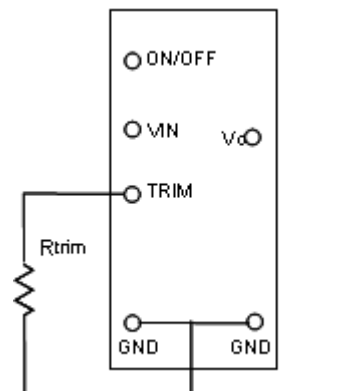

Figure 10. Circuit to Trim Output Voltage

The circuit configuration for trim operation is shown in Figure 10. Because NRT converters use GND as the reference for control, Rtrim should be placed as close to the GND pin as possible, and the trace connecting the GND pin and Rtrim resistor should not carry significant current, to reduce the effect of voltage drop on the GND trace/plain on the output voltage accuracy.

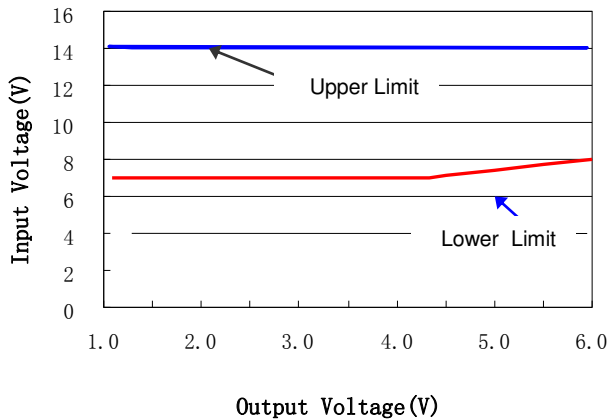

Figure 11. Input Voltage vs Output Voltage Set Point

Certain restrictions apply to the achievable output voltage set point in the range of the input voltage as shown in Figure 11. The Upper Limit curve shows that for all the output voltages, the input voltage should not exceed the maximum of 14V. The Lower Limit curve shows that the input voltage needs to be higher than 7.0V to keep proper operation above 4.5V output.

Output Over-Current Protection

As a standard feature, the converter turns off when the load current exceeds the current limit. If the over-current or short circuit condition persists, the converter will operate in a hiccup mode (repeatedly trying to restart) until the over-current condition is cleared.

Thermal Shutdown

As a standard feature offered by the control IC, the converter will shut down if an over-temperature condition is detected.

The converter will resume operation after the converter cools down.

Design Considerations

Input Source Impedance and Filtering

The stability of the NRT converters, as with any DC/DC converter, may be compromised if the source impedance is too high or too inductive. It's desirable to keep the input source AC impedance as low as possible. To reduce ripple current getting into the input circuit (especially the ground/return conductor), it is desirable to place some low ESR capacitors at the input. Due to the existence of some inductance (such as the trace inductance, connector inductance, etc) in the input circuit, possible oscillation may occur at the input of the converter. We recommend using a combination of ceramic capacitors and Tantalum/Polymer capacitors at the input so that the relatively higher ESR of Tantalum/Polymer capacitors can help damp the possible oscillation between the ceramic capacitors and the inductance.

Similarly, although the converter is designed to be stable with at least 47uF ceramic external capacitors at the output, additional low ESR capacitors at the output may be desirable to further reduce the output voltage ripple or improve the transient response. A combination of ceramic capacitors and Tantalum/Polymer capacitors usually achieves good results.



Mechanical Information

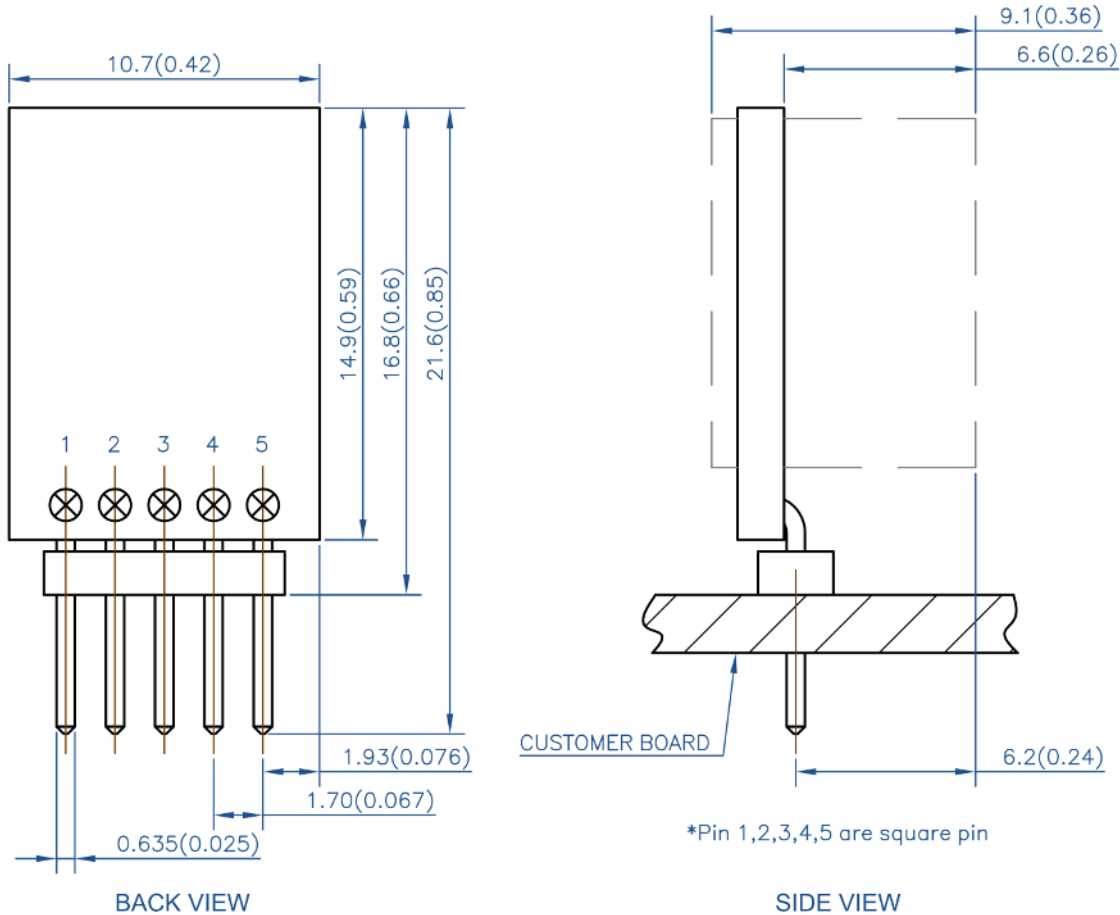

Pin	Name	Function
1	ON/OFF	Input signal for enable control.
2	Vin(+)	Positive terminal of the input voltage
3	GND	Ground terminal, the return or negative terminal of both the input voltage and the output voltage
4	Vout()	Positive terminal of the output voltage
5	Trim(+)	Output voltage adjustment

Notes

- 1) All dimensions in mm (inch) (1 inch = 25.4mm). Tolerances:
.x (.xx): ± 0.5 (0.020")
.xxx: ± 0.25 (0.010")
- 2) All pins are coated with gold or Matte Tin finish.
- 3) Workmanship: Meet or exceeds IPC-A-610 Class II