

### Features

- Frequency range : 32.768 kHz
- SMD seam sealing ceramic package
- Supply voltage : 1.8V ~ 3.3V
- CMOS output
- Tri-state function available
- External dimensions (mm)  
L : 5.0 x W : 3.2 x H : 1.2
- RoHS compliant & Pb free

### Applications

- Real-time clock (RTC)
- PC, NB, Tablet, STB
- Audio, Video, Gaming
- Server, Switch, Router
- Security devices
- Consumer products

### Electrical Characteristics

Item	QTK532	Conditions
Frequency Range ( $F_0$ )	32.768 kHz	
Frequency Stability ( $F_{stab}$ )	$\pm 25$ ppm	-10°C ~ +70°C
	$\pm 50$ ppm, $\pm 25$ ppm	-40°C ~ +85°C
Operating Temperature Range ( $T_{OTR}$ )	-10°C ~ +70°C	
	-40°C ~ +85°C	
Supply Voltage ( $V_{DD}$ )	1.8V, 2.5V, 3.3V	$V_{DD} \pm 10\%$
Current Consumption ( $I_{DD}$ )	3 mA Max.	
Output Type	CMOS	
Output Load ( $C_L$ )	15 pF	
Output Voltage High ( $V_{OH}$ )	90% $V_{DD}$ Min.	
Output Voltage Low ( $V_{OL}$ )	10% $V_{DD}$ Max.	
Rise & Fall Time ( $T_r / T_f$ )	200 ns Max.	10% ~ 90% of $V_{DD}$
Duty Cycle	45% ~ 55%	
Start-up Time	10 ms Max.	
Enable Voltage High, Logic "1"	70% $V_{DD}$ Min.	Input to Pin1 Note [1]
Enable Voltage Low, Logic "0"	30% $V_{DD}$ Max.	
Aging ( $F_{aging}$ )	$\pm 5$ ppm Max.	at 25°C $\pm 3$ °C, first year
Storage Temperature Range ( $T_{STR}$ )	-55°C ~ +125°C	

#### Notes:

[1] Output will be enable if Pin1 is Logic "1" or Open; Output will be disable if Pin1 is Logic "0".

## Dimensions

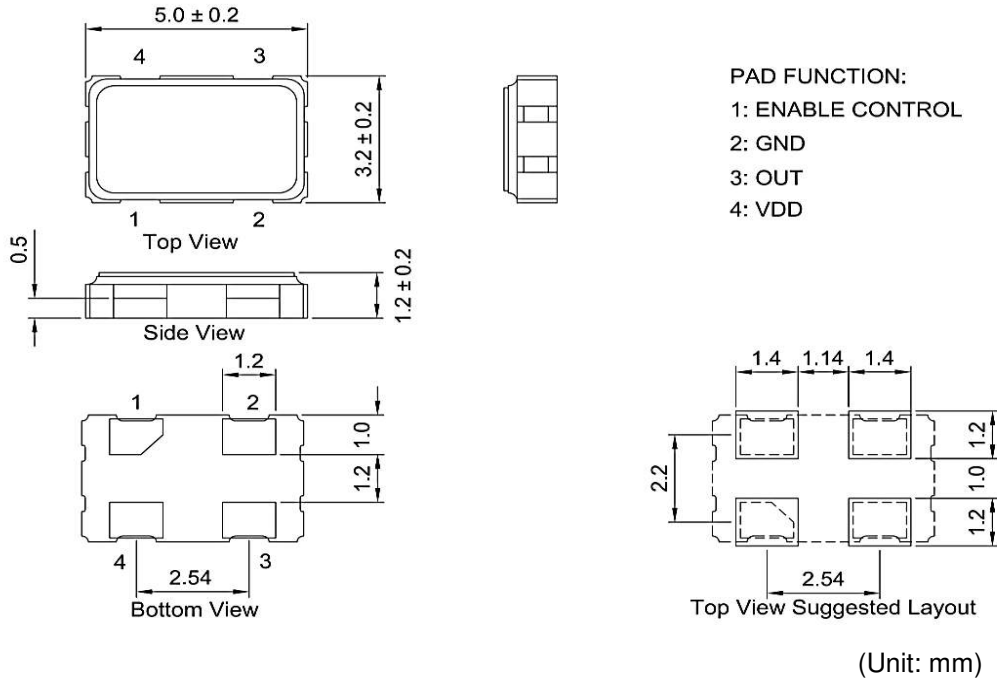

## Ordering Information

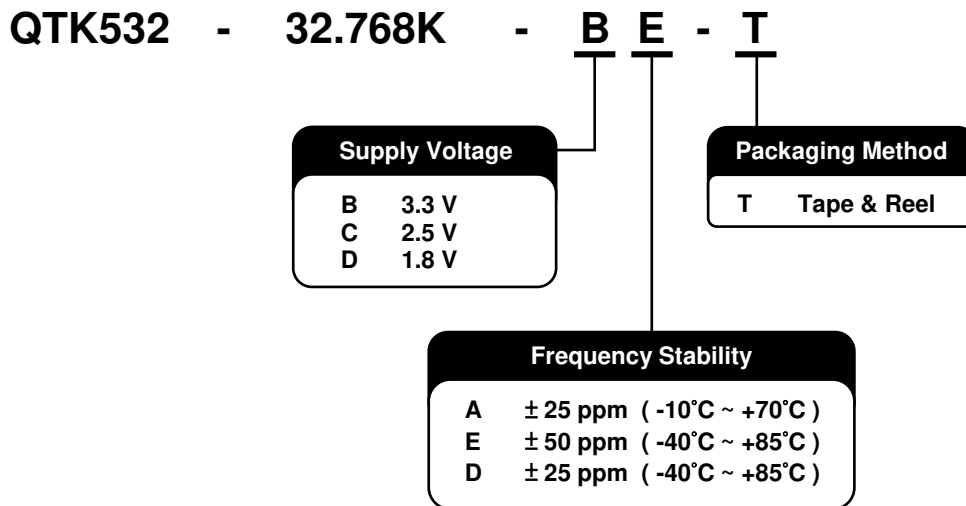

## Packing

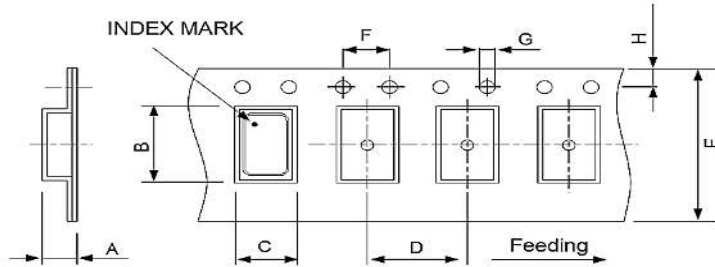

DIMENSIONS	A	B	C	D	E	F	G	H
	1.70	5.4	3.6	8	12	4	1.55	1.75

(Unit: mm)

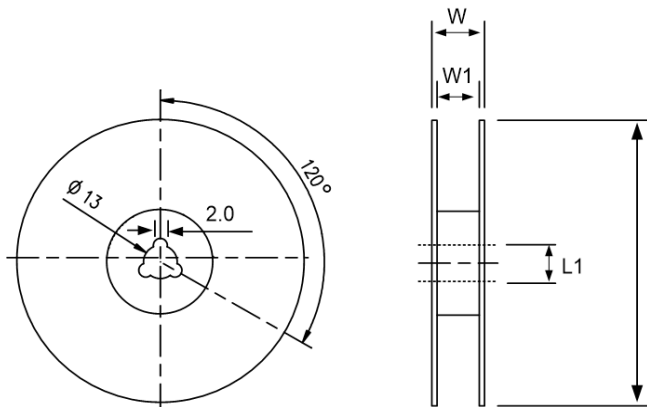

DIMENSIONS	L	L1	W	W1
	180	13	16.5	12

(Unit: mm)

## Reflow Profile

Solder melting point :  $220^{\circ}\text{C} \pm 10^{\circ}\text{C}$ , 60 sec. Min.

Peak temperature :  $260^{\circ}\text{C} \pm 10^{\circ}\text{C}$ , 10 sec. Min.

