

DO NOT SCALE FROM THIS PRINT

DESIGNED & DIMENSIONED IN INCHES[MILLIMETERS]

PRF01-P-C-EE-405-RD

SERIES  
-01: SMA

GENDER  
-P: PLUG

TYPE  
-C: CABLE

FINISH  
-EE: 50μ" EXTRA HEAVY GOLD CENTER CONTACT, 50μ" EXTRA HEAVY GOLD OUTER CONTACT

TERMINATION  
-D: DIRECT SOLDER

ORIENTATION  
-R: RIGHT ANGLE

CABLE TYPE  
-405: RG-405

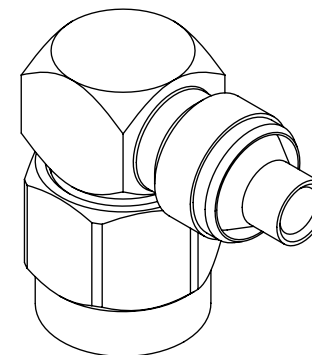
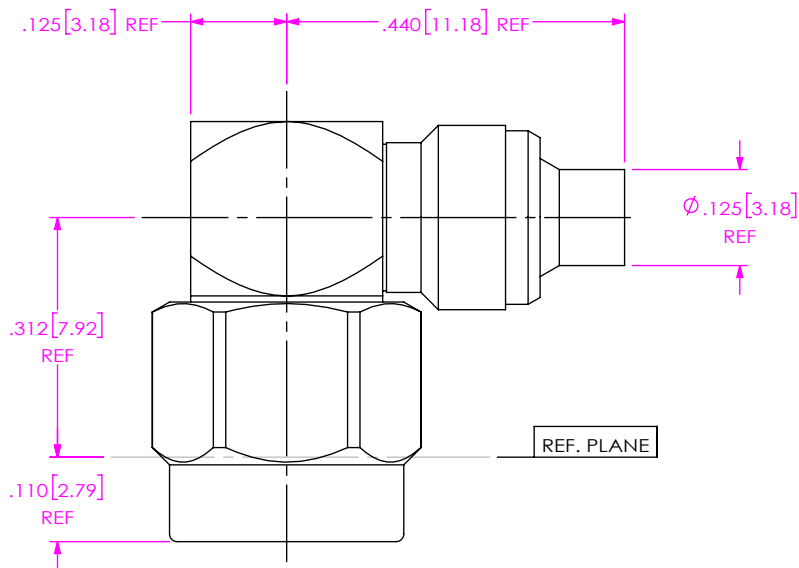

NOTES:

- MATERIAL:  
BODIES, COUPLING NUT: STAINLESS STEEL.  
CONTACT & LOCK RING: BERYLLIUM COPPER.  
BUSHING: BRASS.  
GASKET: SILICONE RUBBER.  
INSULATORS & DIELECTRIC: TEFLON.
- FINISH:  
COUPLING NUT: PASSIVATED.  
CONTACT & BUSHING: GOLD OVER NICKEL PLATE,  
50μ" MIN GOLD OVER 50μ" MIN NICKEL.

3. PCI P/N: 3448.

UNLESS OTHERWISE SPECIFIED,  
DIMENSIONS ARE IN INCHES.  
TOLERANCES ARE:  
DECIMALS                      ANGLES  
.XX: ±.01 [0.3]                      1°  
.XXX: ±.005 [0.13]  
.XXXX: ±.0005 [0.013]

**PROPRIETARY NOTE**  
THIS DOCUMENT CONTAINS CONFIDENTIAL AND PROPRIETARY INFORMATION AND ALL DESIGN, MANUFACTURING, REPRODUCTION, USE, PATENT RIGHTS AND SALES RIGHTS ARE EXPRESSLY RESERVED BY SAMTEC, INC. THIS DOCUMENT SHALL NOT BE DISCLOSED, IN WHOLE OR PART, TO ANY UNAUTHORIZED PERSON OR ENTITY NOR REPRODUCED, TRANSFERRED OR INCORPORATED IN ANY OTHER PROJECT IN ANY MANNER WITHOUT THE EXPRESS WRITTEN CONSENT OF SAMTEC, INC.



520 PARK EAST BLVD, NEW ALBANY, IN 47150  
PHONE: 812-944-6733 FAX: 812-948-5047  
e-Mail: info@SAMTEC.com code 55322

DO NOT SCALE DRAWING

SHEET SCALE: 4:1

DESCRIPTION: SMA RT. ANGLE PLUG, DIRECT SOLDER FOR RG-405 CABLE

DWG. NO. PRF01-P-C-EE-405-RD

BY: EVE L                      09/13/2021                      SHEET 1 OF 2

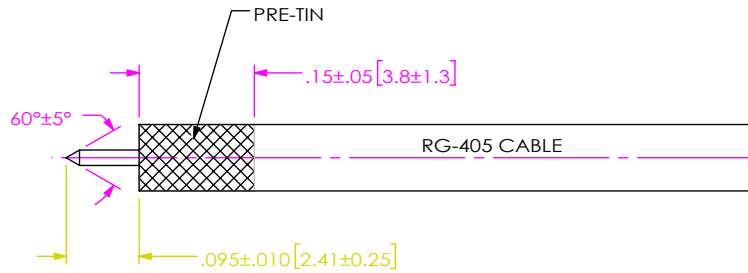

- 1A. TRIM CABLE JACKET TO EXPOSE CENTER CONDUCTOR FOR LENGTH INDICATED.
- 1B. PRE-TIN OUTER JACKET OVER LENGTH INDICATED.

IN-PROCESS 1

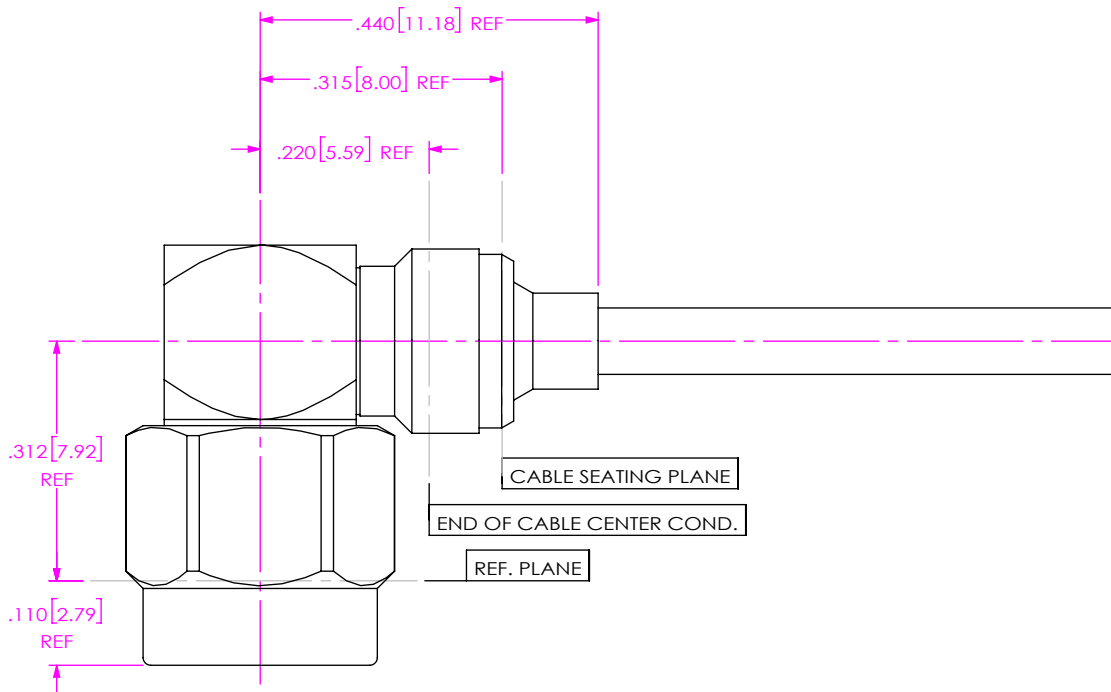

- 2A. INSERT CABLE INTO CONNECTOR BODY UNTIL CABLE PLUGS IN AND FULLY SEATS.
- 2B. APPLY TEAT TO REAR CONNECTOR BODY AND SOLDER CABLE TO BODY WHERE INDICATED.

IN-PROCESS 2

<p>DO NOT SCALE DRAWING</p> <p>SHEET SCALE: 4:1</p>	<p><b>PROPRIETARY NOTE</b></p> <p>THIS DOCUMENT CONTAINS CONFIDENTIAL AND PROPRIETARY INFORMATION AND ALL DESIGN, MANUFACTURING, REPRODUCTION, USE, PATENT RIGHTS AND SALES RIGHTS ARE EXPRESSLY RESERVED BY SAMTEC, INC. THIS DOCUMENT SHALL NOT BE DISCLOSED, IN WHOLE OR PART, TO ANY UNAUTHORIZED PERSON OR ENTITY NOR REPRODUCED, TRANSFERRED OR INCORPORATED IN ANY OTHER PROJECT IN ANY MANNER WITHOUT THE EXPRESS WRITTEN CONSENT OF SAMTEC, INC.</p>	<p><b>samtec</b></p> <p>520 PARK EAST BLVD, NEW ALBANY, IN 47150                  PHONE: 812-944-6733 FAX: 812-948-5047                  e-Mail info@SAMTEC.com code 55322</p>
	<p>DESCRIPTION: SMA RT. ANGLE PLUG, DIRECT SOLDER FOR RG-405 CABLE</p>	
	<p>DWG. NO. PRF01-P-C-EE-405-RD</p>	
<p>BY: EVE L</p>	<p>09/13/2021</p>	<p>SHEET 2 OF 2</p>