

ON Semiconductor

Is Now

onsemi™

To learn more about onsemi™, please visit our website at
www.onsemi.com

onsemi and **onsemi** and other names, marks, and brands are registered and/or common law trademarks of Semiconductor Components Industries, LLC dba "**onsemi**" or its affiliates and/or subsidiaries in the United States and/or other countries. **onsemi** owns the rights to a number of patents, trademarks, copyrights, trade secrets, and other intellectual property. A listing of **onsemi** product/patent coverage may be accessed at www.onsemi.com/site/pdf/Patent-Marking.pdf. **onsemi** reserves the right to make changes at any time to any products or information herein, without notice. The information herein is provided "as-is" and **onsemi** makes no warranty, representation or guarantee regarding the accuracy of the information, product features, availability, functionality, or suitability of its products for any particular purpose, nor does **onsemi** assume any liability arising out of the application or use of any product or circuit, and specifically disclaims any and all liability, including without limitation special, consequential or incidental damages. Buyer is responsible for its products and applications using **onsemi** products, including compliance with all laws, regulations and safety requirements or standards, regardless of any support or applications information provided by **onsemi**. "Typical" parameters which may be provided in **onsemi** data sheets and/or specifications can and do vary in different applications and actual performance may vary over time. All operating parameters, including "Typicals" must be validated for each customer application by customer's technical experts. **onsemi** does not convey any license under any of its intellectual property rights nor the rights of others. **onsemi** products are not designed, intended, or authorized for use as a critical component in life support systems or any FDA Class 3 medical devices or medical devices with a same or similar classification in a foreign jurisdiction or any devices intended for implantation in the human body. Should Buyer purchase or use **onsemi** products for any such unintended or unauthorized application, Buyer shall indemnify and hold **onsemi** and its officers, employees, subsidiaries, affiliates, and distributors harmless against all claims, costs, damages, and expenses, and reasonable attorney fees arising out of, directly or indirectly, any claim of personal injury or death associated with such unintended or unauthorized use, even if such claim alleges that **onsemi** was negligent regarding the design or manufacture of the part. **onsemi** is an Equal Opportunity/Affirmative Action Employer. This literature is subject to all applicable copyright laws and is not for resale in any manner. Other names and brands may be claimed as the property of others.



Is Now Part of



ON Semiconductor®

To learn more about ON Semiconductor, please visit our website at
www.onsemi.com

Please note: As part of the Fairchild Semiconductor integration, some of the Fairchild orderable part numbers will need to change in order to meet ON Semiconductor's system requirements. Since the ON Semiconductor product management systems do not have the ability to manage part nomenclature that utilizes an underscore (_), the underscore (_) in the Fairchild part numbers will be changed to a dash (-). This document may contain device numbers with an underscore (_). Please check the ON Semiconductor website to verify the updated device numbers. The most current and up-to-date ordering information can be found at www.onsemi.com. Please email any questions regarding the system integration to Fairchild_questions@onsemi.com.

ON Semiconductor and the ON Semiconductor logo are trademarks of Semiconductor Components Industries, LLC dba ON Semiconductor or its subsidiaries in the United States and/or other countries. ON Semiconductor owns the rights to a number of patents, trademarks, copyrights, trade secrets, and other intellectual property. A listing of ON Semiconductor's product/patent coverage may be accessed at www.onsemi.com/site/pdf/Patent-Marking.pdf. ON Semiconductor reserves the right to make changes without further notice to any products herein. ON Semiconductor makes no warranty, representation or guarantee regarding the suitability of its products for any particular purpose, nor does ON Semiconductor assume any liability arising out of the application or use of any product or circuit, and specifically disclaims any and all liability, including without limitation special, consequential or incidental damages. Buyer is responsible for its products and applications using ON Semiconductor products, including compliance with all laws, regulations and safety requirements or standards, regardless of any support or applications information provided by ON Semiconductor. "Typical" parameters which may be provided in ON Semiconductor data sheets and/or specifications can and do vary in different applications and actual performance may vary over time. All operating parameters, including "Typicals" must be validated for each customer application by customer's technical experts. ON Semiconductor does not convey any license under its patent rights nor the rights of others. ON Semiconductor products are not designed, intended, or authorized for use as a critical component in life support systems or any FDA Class 3 medical devices or medical devices with a same or similar classification in a foreign jurisdiction or any devices intended for implantation in the human body. Should Buyer purchase or use ON Semiconductor products for any such unintended or unauthorized application, Buyer shall indemnify and hold ON Semiconductor and its officers, employees, subsidiaries, affiliates, and distributors harmless against all claims, costs, damages, and expenses, and reasonable attorney fees arising out of, directly or indirectly, any claim of personal injury or death associated with such unintended or unauthorized use, even if such claim alleges that ON Semiconductor was negligent regarding the design or manufacture of the part. ON Semiconductor is an Equal Opportunity/Affirmative Action Employer. This literature is subject to all applicable copyright laws and is not for resale in any manner.

FEATURES

- Linearly decreasing PWM frequency
- Green-mode under light-load and zero-load conditions
- Constant voltage (CV) and constant current (CC)
- No secondary feedback
- Low start-up current (8μA)
- Low operating current (3.6mA)
- Leading-edge blanking
- Constant power limit
- Universal AC input range
- Synchronized slope compensation
- 140°C OTP sensor with hysteresis
- V_{DD} over-voltage clamping
- Cycle-by-cycle current limiting
- Under-voltage lockout (UVLO)
- Fixed PWM frequency with hopping
- Gate output maximum voltage clamped at 17V
- Small SOT-26 package

APPLICATIONS

Low-power flyback power converters, such as:

- Battery chargers for cellular phones, cordless phones, PDAs, digital cameras, and power tools
- Power adapters for ink jet printers, video game consoles, and portable audio players
- Open-frame SMPS for TV/DVD standby and other auxiliary supplies, home appliances, consumer electronics, and PC 5V standby-power
- Replacements for linear transformers and RCC SMPS

DESCRIPTION

This highly integrated PWM controller provides several features to enhance the performance of low-power flyback converters. To minimize standby power consumption, the proprietary green-mode function provides off-time modulation to linearly decrease the switching frequency under light-load and zero-load conditions. This green-mode function enables the power supply to meet international power conservation requirements. The supply voltage, V_{DD}, is also used for feedback compensation, to regulate the output voltage without requiring a conventional TL431 and a photo-coupler. The typical start-up current is only 8μA, while the typical operating current can be as low as 3.6mA. A large start-up resistance could be used to achieve even higher power conversion efficiency. SGP400 integrates a frequency hopping function, which helps reduce EMI emission of a power supply with minimum line filters. Built-in synchronized slope compensation maintains the stability of peak current-mode control. Proprietary internal compensation ensures constant output power limiting over a universal range of AC input voltages, from 90V_{AC} to 264V_{AC}. Pulse-by-pulse current limiting ensures a constant output current, even if a short-circuit occurs. Also, the internal protection circuit disables PWM output if V_{DD} exceeds 22.7V. The gate output is clamped at 16.7V to protect the power MOS from over-voltage damage. The built-in over temperature protection (OTP) function shuts down the controller at 140°C with a 30°C hysteresis. The SGP400, designed to provide a low-cost total solution for flyback converters, is available in a small footprint, 6-pin, SOT-26 package.

TYPICAL APPLICATION

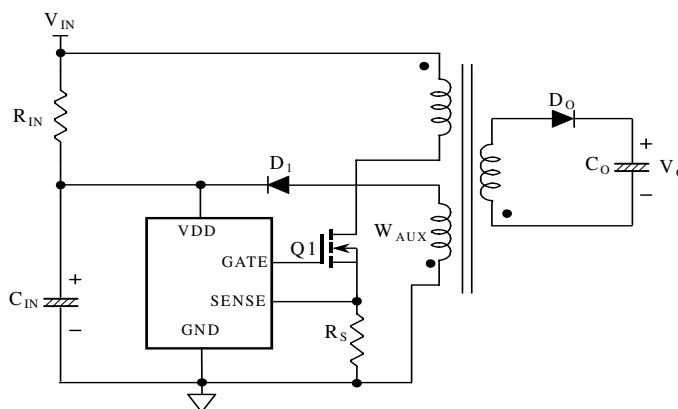

MARKING INFORMATION

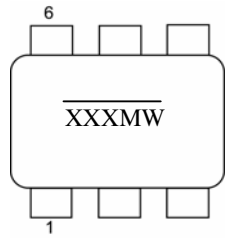

XXX: AAK=SGP400;
 : Lead Free
M: Mask Version
W: Week code A~Z=W1~W26
 A~Z=W27~W52

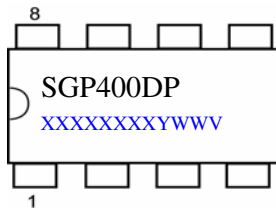

D: D=DIP
P: Z=Lead free
 Null=Regular package
XXXXXXXX: Wafer Lot
Y: Year
WW: Week
V: Assembly Location

PIN CONFIGURATION

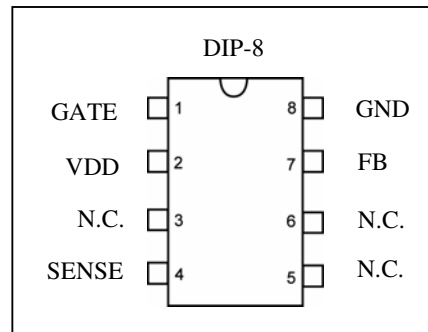
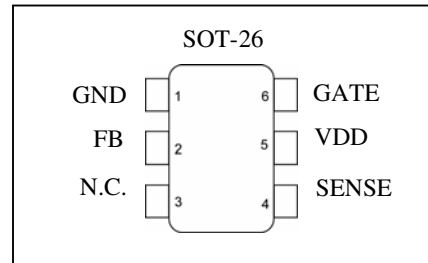

ORDERING INFORMATION

Part Number	PWM Frequency	Pb-Free	Package
SGP400TZ	65KHz		6-Pin SOT-26
SGP400DZ	65KHz		8-Pin DIP-8

PIN DESCRIPTIONS

Name	Pin No.		Type	Function
	DIP-8	SOT-26		
GATE	1	6	Driver Output	The totem-pole output driver to drive the power MOSFET.
VDD	2	5	Supply	Power supply.
NC	3	NA		NC pin.
SENSE	4	4	Analog Input	Current sense. It senses the voltage across a sensed resistor. To provide over-current protection, PWM output is disabled if the voltage exceeds an internal threshold. This pin also provides current information for current-mode control.
NC	5	3		NC pin.
NC	6	NA		NC pin.
FB	7	2	Analog Input	Feedback. The FB pin provides feedback information to the internal PWM comparator. This feedback is used to control the duty cycle. When no feedback is provided, this pin is left open.
GND	8	1	Supply	Ground.

BLOCK DIAGRAM

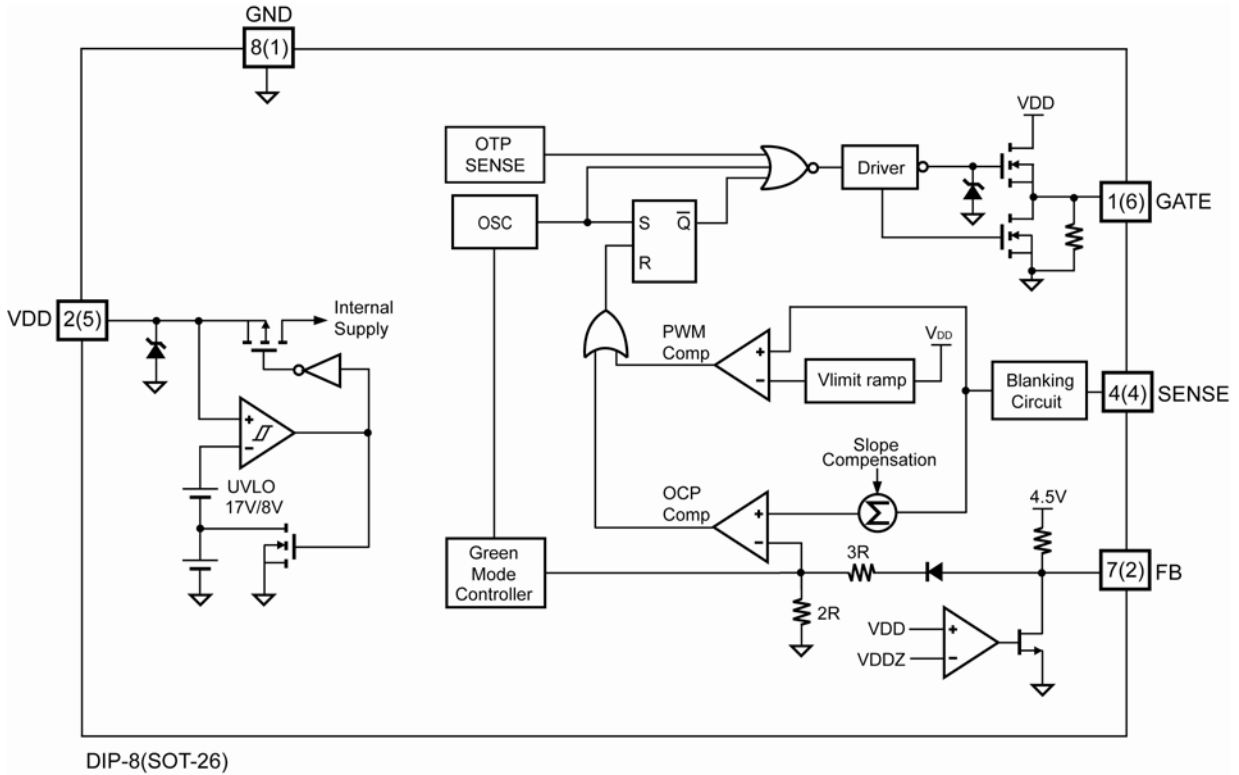

Low-Power Green-Mode PWM Flyback Power Controller without Secondary Feedback
SGP400
ABSOLUTE MAXIMUM RATINGS

Symbol	Parameter	Value	Unit
V _{VDD}	DC Supply Voltage*	30	V
V _{FB}	FB Pin Input Voltage	-0.3 to 7.0	V
V _{SENSE}	Sense Pin Input Voltage	-0.3 to 7	V
P _D	Power Dissipation (T _A =85°C)	SOT-26	247
		DIP-8	478
R _{θJA}	Thermal Resistance (Junction-to-Air)**	SOT-26	263.3
		DIP-8	135.7
R _{θJC}	Thermal Resistance (Junction-to-Case)**	SOT-26	119.6
		DIP-8	67.1
T _J	Operating Junction Temperature	-40 to +125	°C
T _{STG}	Storage Temperature Range	-55 to +150	°C
T _L	Lead Temperature (Wave Soldering or Infrared, 10 Seconds)	260	°C
ESD	Electrostatic Discharge Capability, Human Body Model	4.0	KV
	Electrostatic Discharge Capability, Machine Model	200	V

* All voltage values, except differential voltages, are given with respect to the network ground terminal.

* Stresses beyond those listed under "absolute maximum ratings" may cause permanent damage to the device.

** Thermal resistance • _{JA} test board size: SOT 18×12×1.6mm/FR4; DIP 40×35×1.6mm/FR4.

RECOMMENDED OPERATING CONDITIONS

Symbol	Parameter	Value	Unit
V _{DD}	DC Supply Voltage	With Secondary Feedback	<20
		Without Secondary Feedback	<22.7
T _A	Operating Ambient Temperature	-20 to +85	°C

* For proper operation.

ELECTRICAL CHARACTERISTICS (V_{DD}=15V, T_A=25°C, unless noted)
V_{DD} Section

Symbol	Parameter	Test Condition	Min.	Typ.	Max.	Unit
V _{DD-ON}	Turn-On Threshold Voltage		16	17	18	V
V _{DD-OFF}	Turn-Off Threshold Voltage		7.5	8.0	8.5	V
I _{DD-ST}	Start-up Current	V _{DD} =V _{DD-ON} -0.1V		8	20	μA
I _{DD-OP}	Operating Supply Current	V _{DD} =15V, C _L =1nF		3.6	4.6	mA
V _{DD-G OFF}	V _{DD} Low-threshold Voltage to Exit Green-off Mode			V _{DD-OFF} + 1.2		V

Feedback Input Section

Symbol	Parameter	Test Condition	Min.	Typ.	Max.	Unit
A _V	Input-Voltage to Current-Sense Attenuation			2/5		V/V
V _{FB-OPEN}	Open-Loop Voltage		4.5			V
Z _{FB}	Input Impedance	I _{FB} =0.1mA to 0.2mA		2.4		KΩ
V _{DD-FB}	V _{DD} Feedback Threshold Voltage*	FB is Open	20.7	22.7	24.7	V
		I _{FB} =0.4mA	18.4	20.4	22.4	V

* The feedback input is pulled by a transistor controlled by the V_{DD} signal while V_{DD} ≥ V_{DDZ}.

Current Sense Section

Symbol	Parameter	Test Condition	Min.	Typ.	Max.	Unit
t_{PD}	Propagation Delay			100	150	ns
V_{STHVA}	Current Limiting Valley Threshold Voltage	$V_{DD}=18V$		0.84		V
		$V_{DD}=15V$		0.76		V
		$V_{DD}=10V$		0.62		V
V_{STHFL}	Current Limiting Flat Threshold Voltage	$V_{DD}=18V$		0.98		V
		$V_{DD}=15V$		0.88		V
		$V_{DD}=10V$		0.71		V
t_{LEB}	Leading-Edge Blanking Time		210	310	410	ns

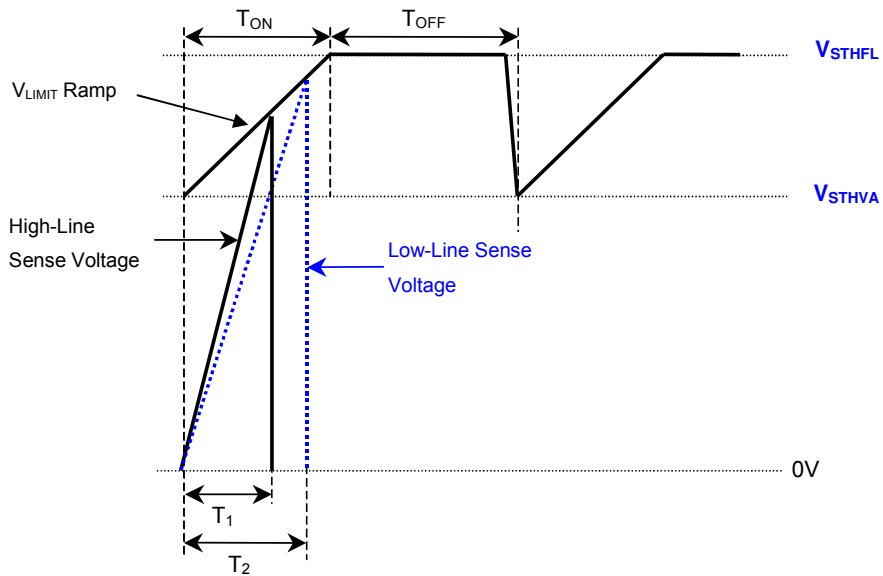

Oscillator Section

Symbol	Parameter	Test Condition	Min.	Typ.	Max.	Unit
F_{OSC}	Frequency	Center Frequency	62	65	68	KHz
		Hopping Range	± 4.1	± 4.6	± 5.1	
t_{HOP}	Hopping Period		4.1	4.0	5.1	ms
F_{OSC-G}	Green-Mode Frequency		19.5	22.0	24.5	KHz
V_{FB-N}	Green-Mode Entry FB Voltage		2.4	2.6	2.8	V
V_{FB-G}	Green-Mode Ending FB Voltage			$V_{FB-N}-0.7$		V
S_G	Green-Mode Modulation Slope		40	70	100	Hz/mV
F_{DV}	Frequency Variation vs. V_{DD} Deviation	$V_{DD}=10$ to $20V$			2	%
F_{DT}	Frequency Variation vs. Temperature Deviation	$T_A=-20$ to $85^\circ C$		1.5	5.0	%

Output Section

Symbol	Parameter	Test Condition	Min.	Typ.	Max.	Unit
DCY _{MAX}	Maximum Duty Cycle		70	75	80	%
V _{GATE-L}	GATE Low Voltage	V _{DD} =15V, I _O =10mA			1.5	V
V _{GATE-H}	GATE High Voltage	V _{DD} =15V, I _O =-10mA	8			V
t _r	GATE Rising Time	V _{DD} =15V, C _L =1nF	150	200	250	ns
t _f	GATE Falling Time	V _{DD} =15V, C _L =1nF	70	90	110	ns
V _{GATE-CLAMP}	GATE Output Clamping Voltage	V _{DD} =20V	16	17	18	V

Over-Temperature Protection (OTP)

Symbol	Parameter	Test Condition	Min.	Typ.	Max.	Unit
Temp- _{OTP}	Protection Junction Temperature [*]			140		°C
Temp-Restart	Restart Junction Temperature ^{**}			110		°C

* When activated, the output is disabled and the latch is turned off.

** The threshold temperature for enabling the output and resetting the latch after over-temperature protection has been activated.

TYPICAL CHARACTERISTICS

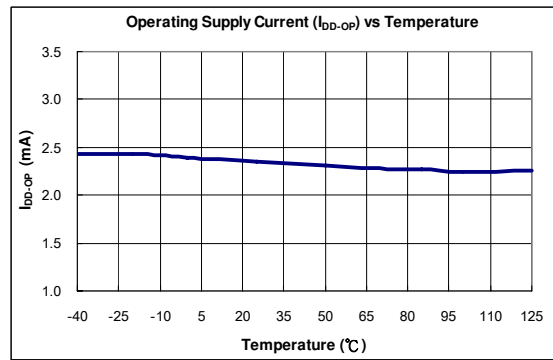
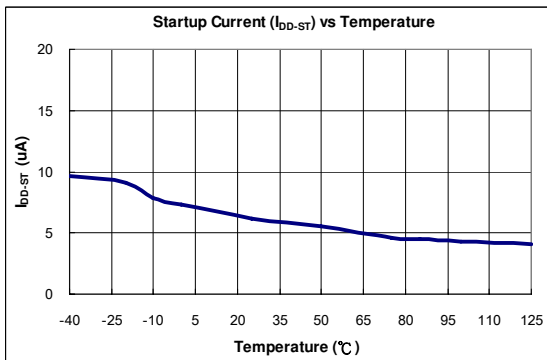
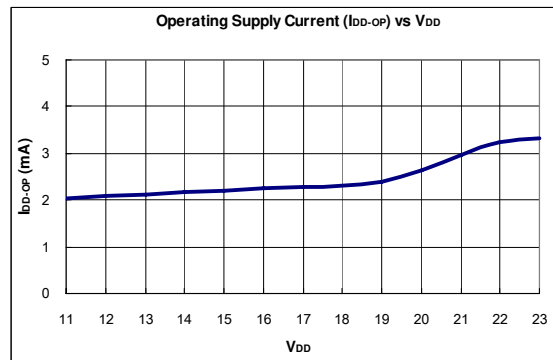
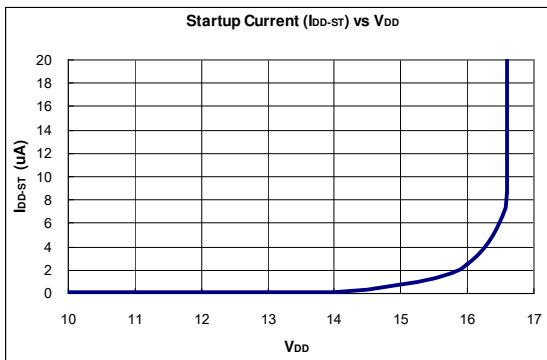
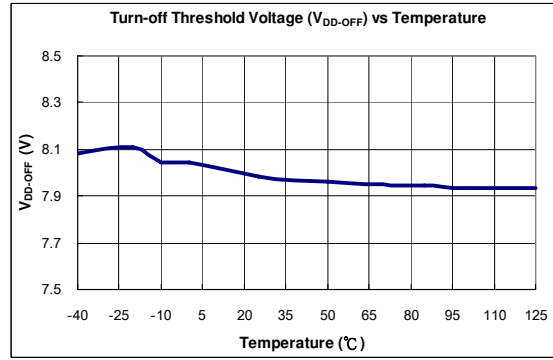
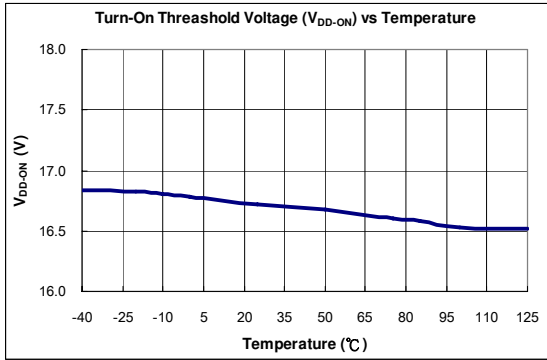

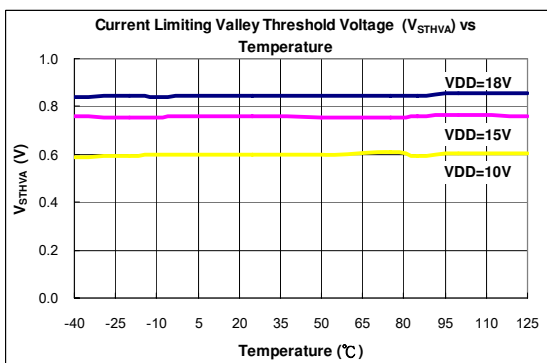
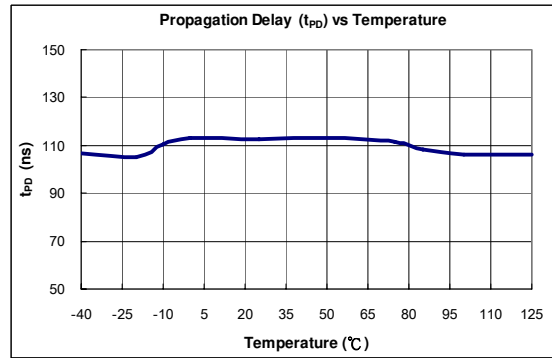
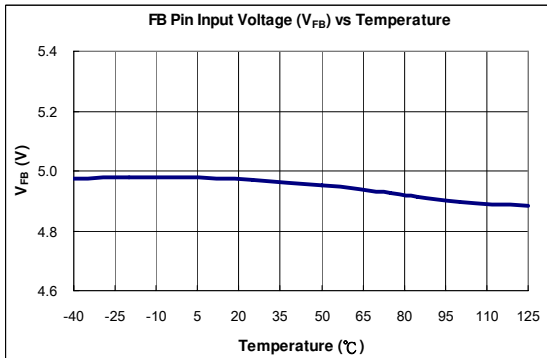
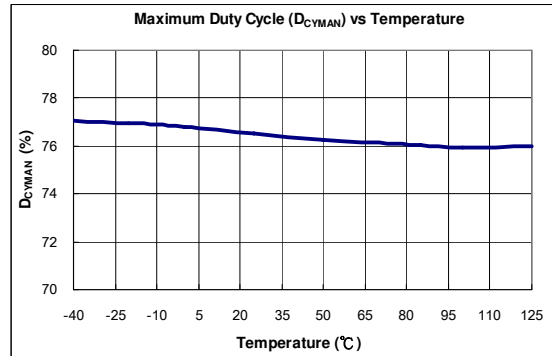
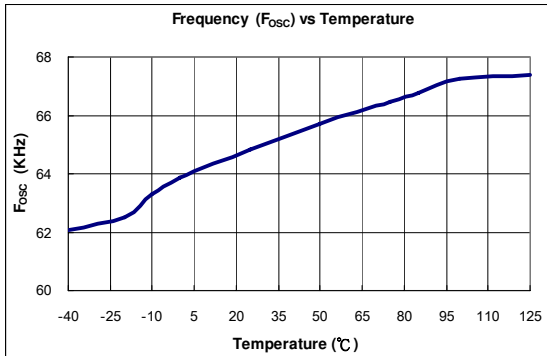

OPERATION DESCRIPTION

SGP400 devices integrate many useful functions for low-power switch-mode power supplies. The following descriptions highlight key features of the SGP400.

Start-up Current

The required start-up current is only 8 μ A, which allows a high-resistance, low-wattage start-up resistor to be used to supply the controller's start-up power. A 1.5M Ω /0.25W start-up resistor can be used over a wide input range (100V-240V AC) with very little power loss.

Operating Current

The operating current is normally 3.6mA. The low operating current results in higher efficiency and reduces the required V_{DD} hold-up capacitance. A 10 μ F/25V V_{DD} hold-up capacitor can be used over a wide input range (100V-240V AC) with very little power loss.

Green-Mode Operation

The proprietary green-mode function provides off-time modulation to linearly decrease the switching frequency under light-load and zero-load conditions. The on-time is limited to provide better protection against brownouts and other abnormal conditions.

This green-mode function dramatically reduces power consumption under light-load and zero-load conditions. Power supplies using the SGP400 can easily meet international restrictions regarding standby power consumption.

Constant Voltage (CV), Constant

Current (CC) without Feedback

The SGP400 can tightly regulate the output voltage and provide over-current protection without requiring secondary-side feedback signals. For improved CV and CC accuracy, the transformer leakage inductance should be reduced as much as possible.

Over-Temperature Protection (OTP)

The SGP400 has a built-in temperature sensing circuit to shut down PWM output if the junction temperature exceeds 140°C. While PWM output is shut down, the V_{DD} voltage gradually drops to the UVLO voltage. Some of the internal circuits are shut down and V_{DD} gradually starts increasing again. When V_{DD} reaches 17V, all the internal circuits, including the temperature sensing circuit, start operating normally. If the junction temperature is still higher than 140°C, the PWM controller shuts down immediately. This situation continues until the temperature drops below 110°C. The PWM output is then turned back on. The temperature hysteresis window for the OTP circuit is 30°C.

V_{DD} Over-Voltage Clamping

V_{DD} over-voltage clamping is built-in to prevent damage from over-voltage conditions. When V_{DD} exceeds 22.7V, PWM output is shut down. Over-voltage conditions may be caused by an open photo-coupler loop or a short-circuit in the output.

Oscillator Operation

The oscillation frequency is fixed at 65KHz.

Leading-Edge Blanking

Each time the power MOSFET switches on, a spike occurs at the sense resistor. To avoid premature termination of the switching pulse, a 310ns leading-edge blanking time is built in. Conventional RC filtering is not necessary. During the blanking period, the current-limit comparator is disabled and cannot switch off the gate drive.

Constant Output Power Limit

When the SENSE voltage across the sense resistor, R_s , reaches the threshold voltage (around 1.0V), the output GATE drive is turned off after a small propagation delay t_{pd} . This propagation delay introduces additional current, proportional to $t_{pd} \cdot V_{IN} / L_p$. The propagation delay is nearly constant, regardless of the input line voltage V_{IN} . Higher input line voltages result in larger additional currents. Under high input-line voltages, the output power limit is higher than under low input-line voltages.

Over a wide range of AC input voltages, the variation can be significant. To compensate for this, the threshold voltage is adjusted by adding a positive ramp (V_{LIMIT_RAMP}). This ramp signal can vary from 0.77V to 1.05V and it flattens out at 1.05V. A smaller threshold voltage forces the output GATE drive to terminate earlier, reducing total PWM turn-on time and making the output power equal to that of the low line input. This proprietary internal compensation feature ensures a constant output power limit over a wide range of AC input voltages ($90V_{AC}$ to $264V_{AC}$).

Under-voltage Lockout (UVLO)

The turn-on/turn-off thresholds are fixed internally at 17V/8V. To enable the SGP400 during start-up, the hold-up capacitor must first be charged to 17V through the start-up resistor.

The hold-up capacitor continues to supply V_{DD} before energy can be delivered from the auxiliary winding of the main transformer. V_{DD} must not drop below 8V during this start-up process. This UVLO hysteresis window ensures that the hold-up capacitor can adequately supply V_{DD} during start-up.

Gate Output

The BiCMOS output stage is a fast totem pole gate driver. Cross-conduction has been avoided to minimize heat dissipation, increase efficiency, and enhance reliability. The output driver is clamped by an internal 17V Zener diode to protect the power MOSFET transistors against any harmful over-voltage gate signals.

Slope Compensation

The sensed voltage across the current sense resistor is used for current-mode control and pulse-by-pulse current limiting. The built-in slope compensation function improves power supply stability and prevents sub-harmonic oscillations that normally would occur because of peak current mode control. A positively sloped, synchronized ramp is activated with every switching cycle. The slope of the ramp is:

$$\frac{0.33 \times \text{Duty}}{\text{Duty(max)}} \quad (1)$$

Noise Immunity

Noise from the current sense or the control signal may cause significant pulse-width jitter, particularly in continuous-conduction mode. Slope compensation helps alleviate this problem. Good placement and layout practices should be followed. Avoid long PCB traces and component leads. Compensation and filter components should be located near the SGP400. Finally, increasing the power-MOS gate resistance is advised.

REFERENCE CIRCUIT

3W Flyback 5V/0.6A Circuit, without Secondary-Side Feedback

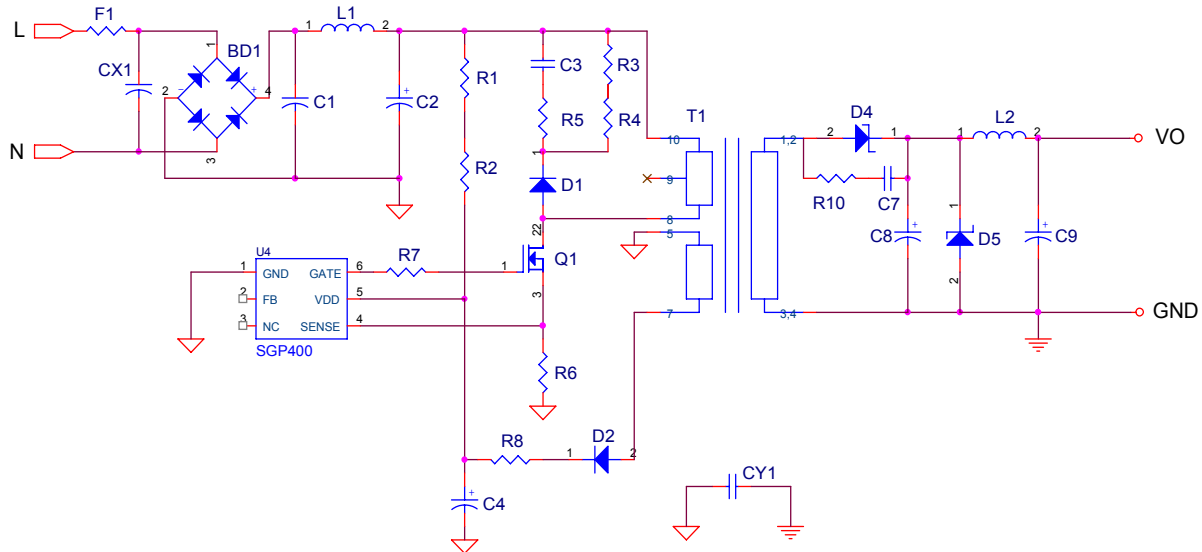

BOM

Symbol	Component	Symbol	Component
BD1 (Reference only)	BD DI106 1A/600V	F1	R 1Ω/0.5W
CX1 (Option)	YC 472pF/400V (Y1)	L1	Inductor 20mH 6•8mm
CY1 (Option)	YC 102pF/400V (Y1)	L2	Inductor 10μH 6mm
C1	CC 0.01μF/500V	Q1	MOSFET 1A/600V
C2	EC 10μF/400V 105°C	R1,R2	R 750kΩ/1206
C3	CC 1000pF/500V	R3,R4	R 47kΩ/1206
C4	EC 10μF/50V	R5	R 47Ω/1206
C7 (Option)	CC 102pF/100V 1206	R6	R 4.7Ω/0.5W
C8	EC 470μF/10V 105°C	R7	R 100Ω/0805
C9	EC 220μF/10V 105°C	R8	R 10Ω/1206
D1	Diode FRI07	R10 (Option)	R 10Ω/1206
D2	Diode FR102	T1	Transformer EE-16
D4	Diode SB360	U4	IC SGP400 (Green PWM IC)
D5 (Option)	ZD 6.8V/0.5W		

3W Flyback 5V/0.6A Circuit, with Secondary-Side Feedback

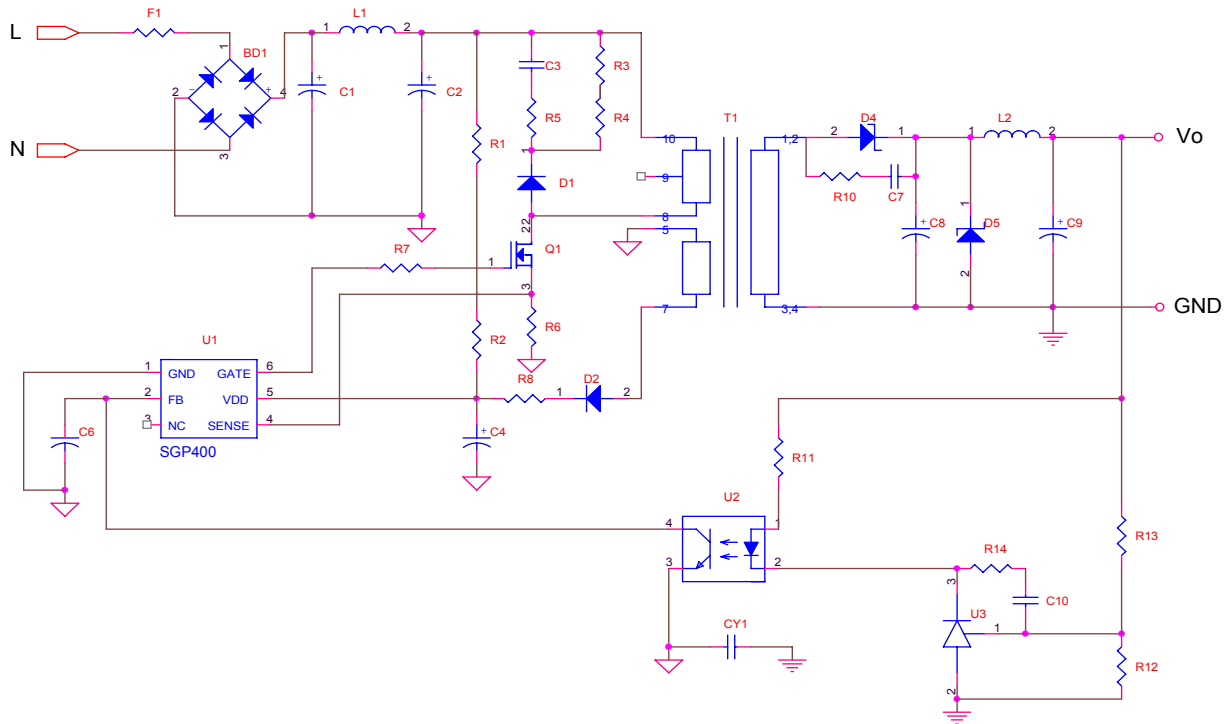

BOM

Symbol	Component	Symbol	Component
BD1 (Reference only)	BD DI106 1A/600V	L2	Inductor 10µH 6mm
CY1 (Option)	YC 102p/400V	Q1	MOSFET 1A/600V
C1	CC 0.01µF/500V	R1,R2	R 750kΩ/1206
C2	EC 10µF/400V 105°C	R4,R3	R 47kΩ/1206
C3	CC 1000p/500V	R5	R 47Ω/1206
C4	EC 10µ/50V	R6	R 4.7Ω/0.5W
C6	CC 472p/0805	R7	R 100Ω/0805
C7	CC 102p/100V 1206	R10	R 10Ω/1206
C8	EC 470µ/10V 105°C	R8	R 10Ω/1206
C9	EC 470µ/10V 105°C	R11	R 100Ω/ 1/8W
C10	CC 222p/0805	R12	R 33kΩ/0805
D1	Diode FR107	R13	R 33kΩ/ 1/8W
D2	Diode FR102	R14	R 4.7kΩ/0805
D4	Diode SB360	T1	Transformer EE-16
D5 (Option)	ZD 6.8V/0.5W	U1	IC SGP400 (Green PWM IC)
F1	R 1Ω/0.5W Resistor	U2	IC PC817
L1	Inductor 20mH 6*8mm	U3	IC TL431

PACKAGE INFORMATION

6 PINS-SOT (T)

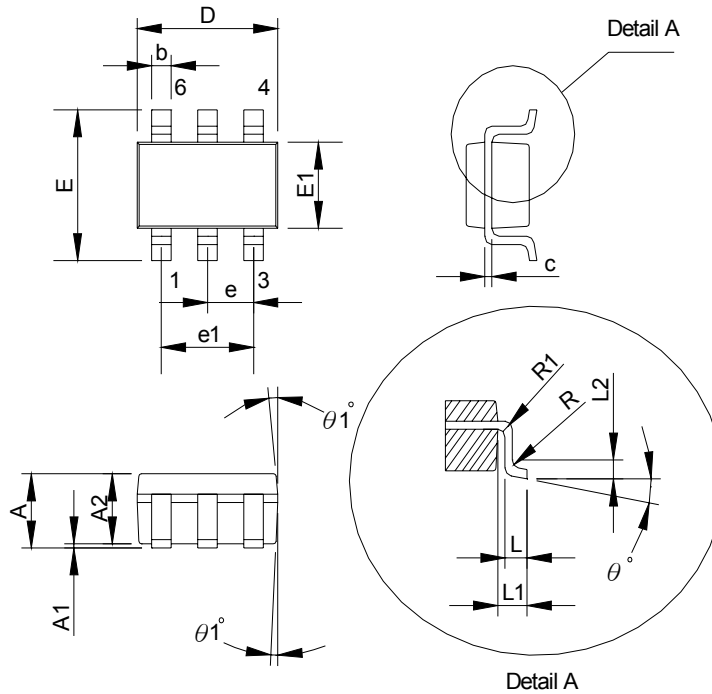

Dimensions:

Symbol	Millimeters			Inches		
	Min.	Typ.	Max.	Min.	Typ.	Max.
A			1.45			0.057
A1			0.15			0.006
A2	0.90	1.15	1.30	0.036	0.045	0.051
b	0.30		0.50	0.011		0.020
c	0.08		0.22	0.003		0.009
D		2.90			0.114	
E		2.80			0.110	
E1		1.60			0.063	
e		0.95			0.037	
e1		1.90			0.075	
L	0.30	0.45	0.60	0.020	0.018	0.24
L1		0.60			0.024	
L2		0.25			0.010	
R	0.10			0.004		
R1	0.10		0.25	0.004		0.25
theta°	0°	4°	8°	0°	4°	8°
theta1°	5°	10°	15°	5°	10°	15°

8 PINS-DIP (D)

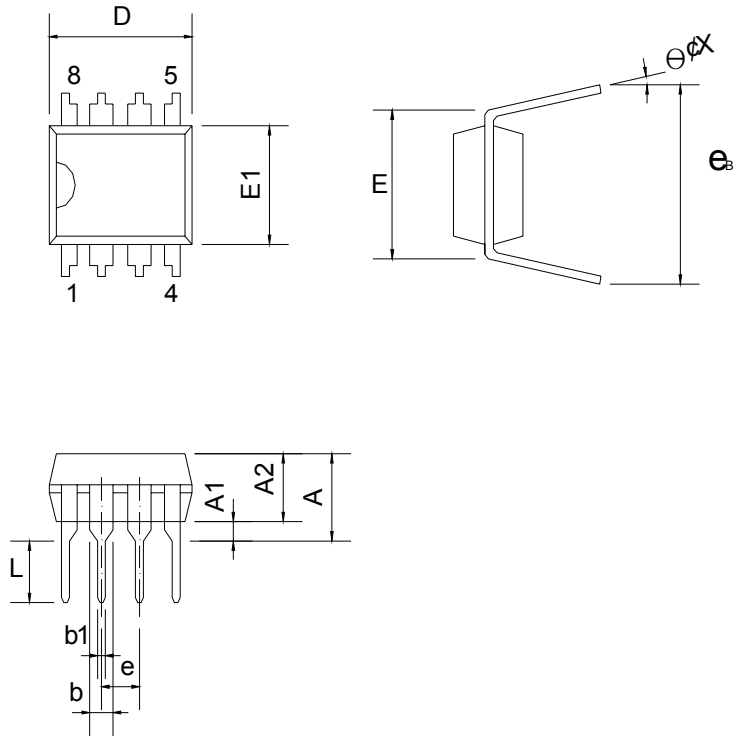

Dimensions:

Symbol	Millimeter			Inch		
	Min.	Typ.	Max.	Min.	Typ.	Max.
A			5.334			0.210
A1	0.381			0.015		
A2	3.175	3.302	3.429	0.125	0.130	0.135
b		1.524			0.060	
b1		0.457			0.018	
D	9.017	9.271	10.160	0.355	0.365	0.400
E		7.620			0.300	
E1	6.223	6.350	6.477	0.245	0.250	0.255
e		2.540			0.100	
L	2.921	3.302	3.810	0.115	0.130	0.150
e _B	8.509	9.017	9.525	0.335	0.355	0.375
θ°	0	7	15	0	7	15

Low-Power Green-Mode PWM Flyback Power Controller without Secondary Feedback

SGP400



TRADEMARKS

The following are registered and unregistered trademarks and service marks Fairchild Semiconductor owns or is authorized to use and is not intended to be an exhaustive list of all such trademarks.

ACEX [®]	Green FPS [™]	Power247 [®]	SuperSOT [™] -8
Build it Now [™]	Green FPS [™] e-Series [™]	POWEREDGE [®]	SyncFET [™]
CorePLUS [™]	GTO [™]	Power-SPM [™]	The Power Franchise [®]
CROSSVOLT [™]	i-Lo [™]	PowerTrench [®]	the power franchise
CTL [™]	IntelliMAX [™]	Programmable Active Droop [™]	TinyBoost [™]
Current Transfer Logic [™]	ISOPLANAR [™]	QFET [®]	TinyBuck [™]
EcoSPARK [®]	MegaBuck [™]	QS [™]	TinyLogic [®]
F [®]	MICROCOUPLER [™]	QT Optoelectronics [™]	TINYOPTO [™]
Fairchild [®]	MicroFET [™]	Quiet Series [™]	TinyPower [™]
Fairchild Semiconductor [®]	MicroPak [™]	RapidConfigure [™]	TinyPWM [™]
FACT Quiet Series [™]	MillerDrive [™]	SMART START [™]	TinyWire [™]
FACT [®]	Motion-SPM [™]	SPM [®]	μSerDes [™]
FAST [®]	OPTOLOGIC [®]	STEALTH [™]	UHC [®]
FastvCore [™]	OPTOPLANAR [®]	SuperFET [™]	UniFET [™]
FPST [™]	 [®]	SuperSOT [™] -3	VCX [™]
FRFET [®]	PDP-SPM [™]	SuperSOT [™] -6	
Global Power Resource SM	Power220 [®]		

DISCLAIMER

FAIRCHILD SEMICONDUCTOR RESERVES THE RIGHT TO MAKE CHANGES WITHOUT FURTHER NOTICE TO ANY PRODUCTS HEREIN TO IMPROVE RELIABILITY, FUNCTION, OR DESIGN. FAIRCHILD DOES NOT ASSUME ANY LIABILITY ARISING OUT OF THE APPLICATION OR USE OF ANY PRODUCT OR CIRCUIT DESCRIBED HEREIN; NEITHER DOES IT CONVEY ANY LICENSE UNDER ITS PATENT RIGHTS, NOR THE RIGHTS OF OTHERS. THESE SPECIFICATIONS DO NOT EXPAND THE TERMS OF FAIRCHILD'S WORLDWIDE TERMS AND CONDITIONS, SPECIFICALLY THE WARRANTY THEREIN, WHICH COVERS THESE PRODUCTS.

LIFE SUPPORT POLICY

FAIRCHILD'S PRODUCTS ARE NOT AUTHORIZED FOR USE AS CRITICAL COMPONENTS IN LIFE SUPPORT DEVICES OR SYSTEMS WITHOUT THE EXPRESS WRITTEN APPROVAL OF FAIRCHILD SEMICONDUCTOR CORPORATION.

As used herein:

1. Life support devices or systems are devices or systems which, (a) are intended for surgical implant into the body or (b) support or sustain life, and (c) whose failure to perform when properly used in accordance with instructions for use provided in the labeling, can be reasonably expected to result in a significant injury of the user.
2. A critical component in any component of a life support, device, or system whose failure to perform can be reasonably expected to cause the failure of the life support device or system, or to affect its safety or effectiveness.

PRODUCT STATUS DEFINITIONS

Definition of Terms

Datasheet Identification	Product Status	Definition
Advance Information	Formative or In Design	This datasheet contains the design specifications for product development. Specifications may change in any manner without notice.
Preliminary	First Production	This datasheet contains preliminary data; supplementary data will be published at a later date. Fairchild Semiconductor reserves the right to make changes at any time without notice to improve design.
No Identification Needed	Full Production	This datasheet contains final specifications. Fairchild Semiconductor reserves the right to make changes at any time without notice to improve design.
Obsolete	Not In Production	This datasheet contains specifications on a product that has been discontinued by Fairchild Semiconductor. The datasheet is printed for reference information only.

Rev. 131

ON Semiconductor and  are trademarks of Semiconductor Components Industries, LLC dba ON Semiconductor or its subsidiaries in the United States and/or other countries. ON Semiconductor owns the rights to a number of patents, trademarks, copyrights, trade secrets, and other intellectual property. A listing of ON Semiconductor's product/patent coverage may be accessed at www.onsemi.com/site/pdf/Patent-Marking.pdf. ON Semiconductor reserves the right to make changes without further notice to any products herein. ON Semiconductor makes no warranty, representation or guarantee regarding the suitability of its products for any particular purpose, nor does ON Semiconductor assume any liability arising out of the application or use of any product or circuit, and specifically disclaims any and all liability, including without limitation special, consequential or incidental damages. Buyer is responsible for its products and applications using ON Semiconductor products, including compliance with all laws, regulations and safety requirements or standards, regardless of any support or applications information provided by ON Semiconductor. "Typical" parameters which may be provided in ON Semiconductor data sheets and/or specifications can and do vary in different applications and actual performance may vary over time. All operating parameters, including "Typicals" must be validated for each customer application by customer's technical experts. ON Semiconductor does not convey any license under its patent rights nor the rights of others. ON Semiconductor products are not designed, intended, or authorized for use as a critical component in life support systems or any FDA Class 3 medical devices or medical devices with a same or similar classification in a foreign jurisdiction or any devices intended for implantation in the human body. Should Buyer purchase or use ON Semiconductor products for any such unintended or unauthorized application, Buyer shall indemnify and hold ON Semiconductor and its officers, employees, subsidiaries, affiliates, and distributors harmless against all claims, costs, damages, and expenses, and reasonable attorney fees arising out of, directly or indirectly, any claim of personal injury or death associated with such unintended or unauthorized use, even if such claim alleges that ON Semiconductor was negligent regarding the design or manufacture of the part. ON Semiconductor is an Equal Opportunity/Affirmative Action Employer. This literature is subject to all applicable copyright laws and is not for resale in any manner.

PUBLICATION ORDERING INFORMATION

LITERATURE FULFILLMENT:

Email Requests to: orderlit@onsemi.com

ON Semiconductor Website: www.onsemi.com

TECHNICAL SUPPORT

North American Technical Support:
Voice Mail: 1 800-282-9855 Toll Free USA/Canada
Phone: 011 421 33 790 2910

Europe, Middle East and Africa Technical Support:
Phone: 00421 33 790 2910

For additional information, please contact your local Sales Representative