

2

1

PANDUIT P/N	WEIGHT
ACD01	1.0kg

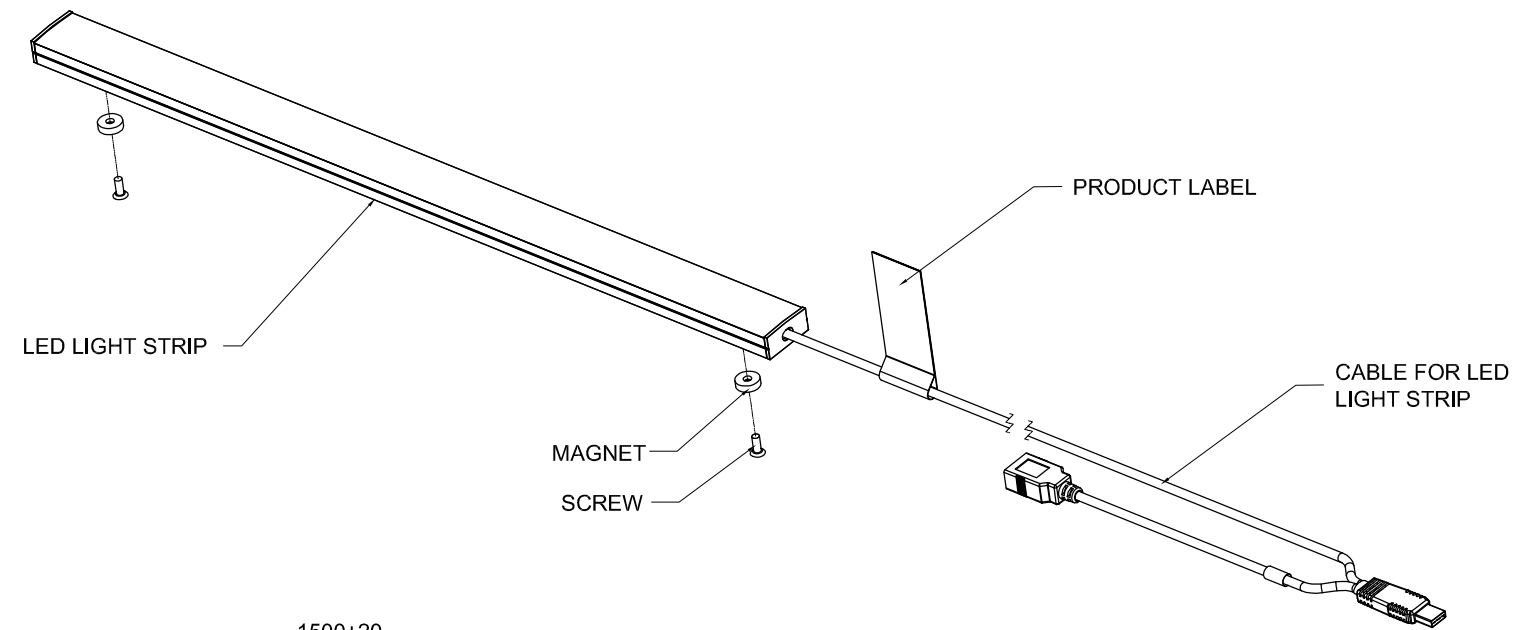

SPECIFICATION:

- 1. STANDARD
 - OPERATING TEMPERATURE RANGE: 0°C TO 65°C [32°F TO 149°F]
 - OPERATIONAL VOLTAGE: 5 ±0.1 VOLTS
 - CURRENT DRAW: 300 mA MAX
 - INTERFACE PLUG: USB A
 - INTERFACE PLUG HOUSING MATERIAL: PVC
 - INTERFACE PLUG HOUSING COLOR: BLACK
- 2. ADDITIONAL:
 - NONE
- 3. ACCESSORY COMPONENTS:
 - DOOR SWITCH SENSOR, QTY:(1)
 - CABLE TIES, QTY:(5)
 - DOUBLE SIDED TAPE, QTY:(2)
 - ADHESIVE BACKED MOUNT, QTY:(5)
 - TAP SCREW, QTY:(4)
 - INSTALLATION GUIDE, QTY:(1)

NOTES:

- 1. PRIMARY DIMENSIONS ARE IN MILLIMETERS. SECONDARY DIMENSION ARE IN INCHES
- 2. INSTALLATION SHALL COMPLY WITH ALL APPLICABLE NATIONAL, STATE, AND LOCAL CODES
- 3. VISIT OUR ON-LINE CATALOG AT WWW.PANDUIT.COM FOR A CURRENT LIST OF PRODUCTS APPLICABLE FOR USE WITH THIS PART

IDENTIFICATION

PART NUMBER	DESCRIPTION
ACD01	USB LIGHT STRIP

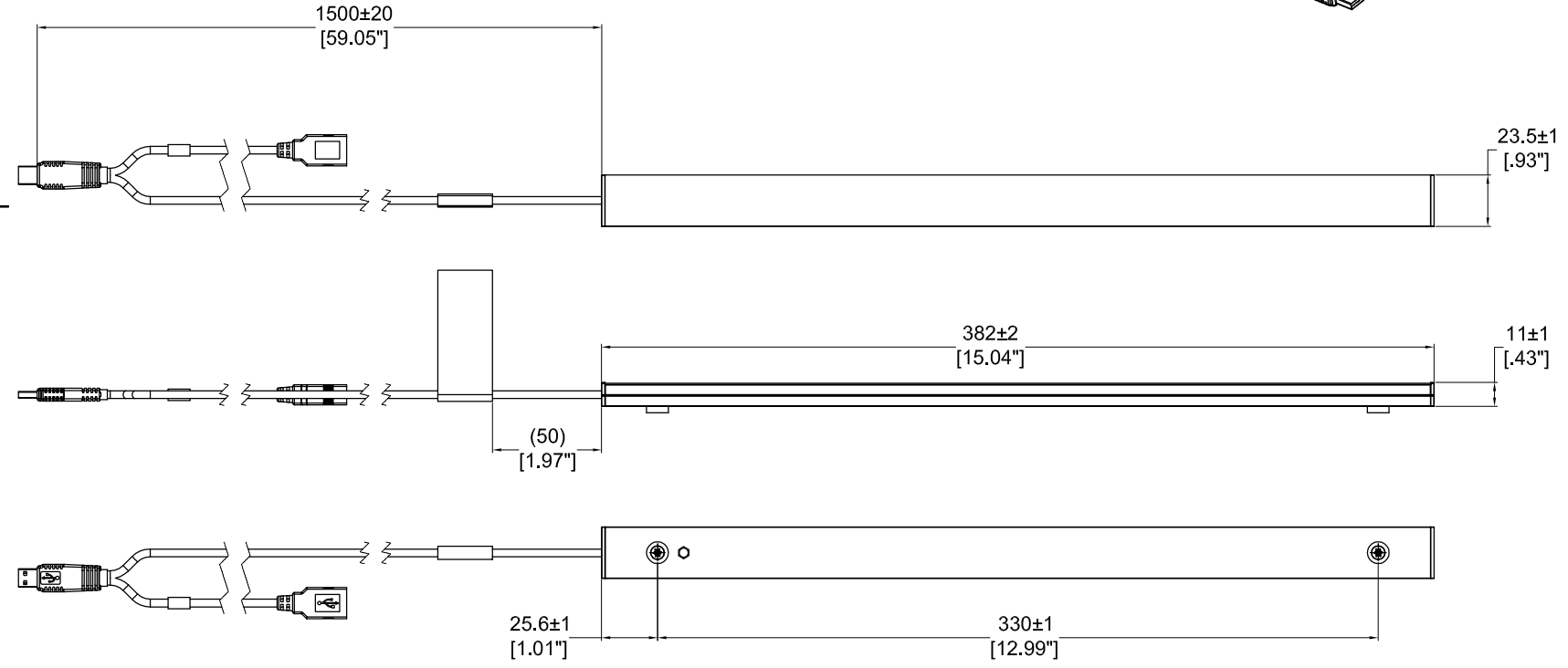

WE ASK THAT YOU CHECK FULLY THE DIMENSIONS, NOTES, AND SIGN THE CLIENT SIGNATURE BOX. THE JOB WILL NOT PROGRESS WITHOUT SIGNED APPROVAL. PLEASE DO NOT DELAY IN RETURNING PROOF AS IT WILL AFFECT DELIVERY.	SIGN	_____
	DATE	_____
	PRINT	_____

TITLE: SMARTZONE G5 USB LIGHT STRIP
CUSTOMER DRAWING

ITEM REVISION NAME: _____
DATASHEET FILE NAME: _____



UNLESS OTHERWISE SPECIFIED DIMENSIONAL TOLERANCE ARE: mm [IN]
Wire Harness Tolerance(mm)

0<L<500	±10
500<L<2000	±20
2000<L<6000	±50

THIRD ANGLE PROJECTION

MATERIAL/COLOR: N/A
DRAWING NUMBER: ACD01_DC

DRAWN BY	DATE	CHK	SCALE	SHT 1 OF 1	SCALE B
Felix	01/04/2018	MM	NONE		

00A	01/04/2018	Felix	MM	DJB	INITIAL RELEASE	ACD01
REV	DATE	BY	CHK	APR	DESCRIPTION	ECN

2

1