

ISS.	AMEND	DATE
1	ISSUED	16/05/19

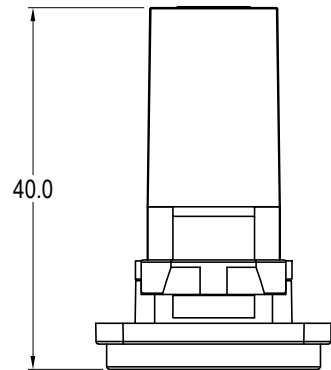
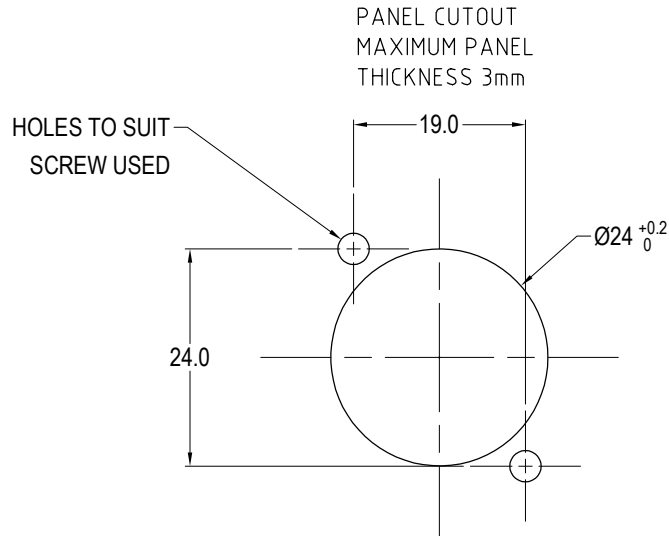

Material:

1. Insert: ABS
2. Frame: Polyamide UL94 V-2
3. Contacts: Gold Plated

VARIANTS	
PART NO.	HOLE DETAILS
CP30202	HOLE Ø3.50 X CSK 82° X Ø5.85
CP30202X	PLAIN HOLE Ø2.50

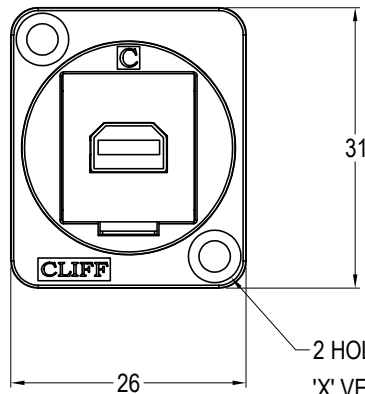

2 HOLES: Ø3.5mm CSK 82° x Ø5.85
'X' VERSION HAS Ø2.5 HOLES.

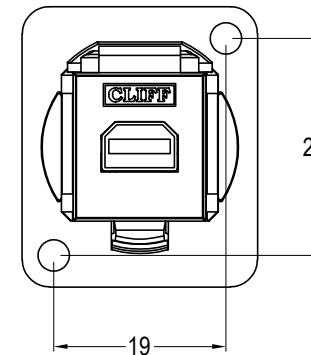
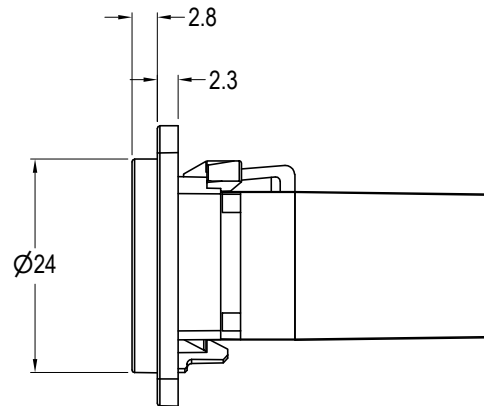

RoHS
COMPLIANT

TOLERANCE
NO DEC. PLACE ±
1 DEC. PLACE ±
2 DEC. PLACE ±
HOLE Ø ±
ANGLES ±
UNLESS
OTHERWISE STATED

DO NOT SCALE

Cliff Electronic Components Ltd.

76 Holmethorpe Avenue, Holmethorpe Industrial Estate,
Redhill, Surrey, RH1 2PF, England, UK
Tel: 01737-771375 Fax: 01737-766012 Website: www.cliffuk.co.uk

THE CONTENTS OF THIS DOCUMENT MUST NOT BE COPIED OR DISCLOSED
TO A 3rd PARTY WITHOUT WRITTEN PERMISSION OF CLIFF UK. © 2019

DIMENSIONS IN MILLIMETERS UNLESS OTHERWISE STATED. WORK TO DIMENSIONS. REMOVE ALL BURRS. IF IN DOUBT ASK.

3rd ANGLE PROJECTION:

MATERIAL: See Notes

FINISH: See Notes

DRAWN: T.J.O.

APPROVED: D.P.J.

TITLE: FEED THROUGH MINI DISPLAY PORT

DRWG. No. **CP30202**

FORM: A4DRWGF