

THIS DRAWING IS UNPUBLISHED. RELEASED FOR PUBLICATION
 © COPYRIGHT - By - ALL RIGHTS RESERVED.

LOC	DIST	REVISIONS					
		P	LTR	DESCRIPTION	DATE	DWN	APVD
AF	50	C1		ECR-13-016672	25OCT13	PKS	RRP

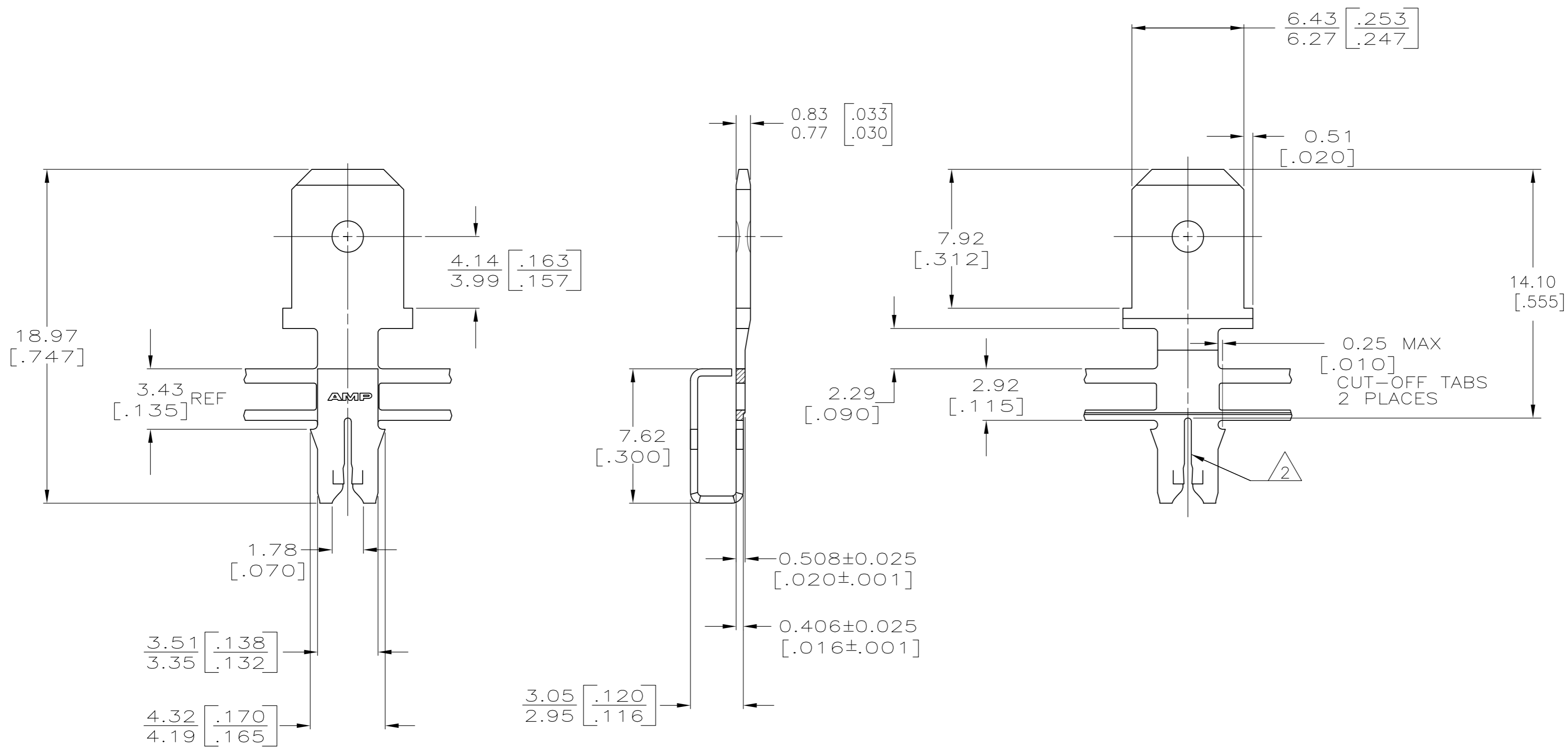

- 1 CONTINUOUS STRIP ON REELS WITH TERMINALS LOCATED ON 8.38±0.08 [.330±.003] CENTERS.
- 2 SLOT TERMINATES EITHER A SINGLE OR DOUBLE MAGNET WIRE OF THE SAME SIZE AND TYPE. COPPER RANGE IS 0.64-0.81mm [#22-#20] AWG.
- 3 AFTER INSERTION INTO PLASTIC HOLDER TAB PORTION MUST BE BENT OVER 45° TO 90° OR POTTED-IN TO PREVENT PULL-OUT WHEN MATING RECEPTACLE IS DISCONNECTED.
- 4 SPECIAL CAVITY ANVIL HEIGHT REQUIRED 3.30±0.07 [.130±.003] REF. APPLICATION SPEC. 114-2046, SEC. 3.2, NOTE 7.



1217924-1
PART NUMBER

THIS DRAWING IS A CONTROLLED DOCUMENT.		DWN MICHAEL S. FEHER 03MAR2003																				
DIMENSIONS: mm [INCHES]		CHK KURT A. RANDOLPH 03MAR2003																				
TOLERANCES UNLESS OTHERWISE SPECIFIED:		APVD KURT A. RANDOLPH 03MAR2003	NAME TAB, 6.35 [.250] FASTON, 300 SERIES MAG-MATE																			
<table border="0"> <tr><td>0 PLC</td><td>±</td><td>-</td></tr> <tr><td>1 PLC</td><td>±</td><td>-</td></tr> <tr><td>2 PLC</td><td>±</td><td>0.25 [.010]</td></tr> <tr><td>3 PLC</td><td>±</td><td>-</td></tr> <tr><td>4 PLC</td><td>±</td><td>-</td></tr> <tr><td>ANGLES</td><td>±</td><td>-</td></tr> </table>		0 PLC	±	-	1 PLC	±	-	2 PLC	±	0.25 [.010]	3 PLC	±	-	4 PLC	±	-	ANGLES	±	-	PRODUCT SPEC 108-2012	RESTRICTED TO	
0 PLC	±	-																				
1 PLC	±	-																				
2 PLC	±	0.25 [.010]																				
3 PLC	±	-																				
4 PLC	±	-																				
ANGLES	±	-																				
MATERIAL BRASS		FINISH TIN PLATE	APPLICATION SPEC 114-2046 4	SIZE A2																		
		WEIGHT -	CAGE CODE 00779	DRAWING NO 1217924																		
		CUSTOMER DRAWING	SCALE 5:1	SHEET 1 OF 1																		
			REV C1																			