

Data Sheet

SMT-0440-T-R

Though extremely small, the SMT-0440 series transducers are constructed almost exactly the same as electro-mechanical transducers three times their size. What this means for users is that PUI Audio is leveraging their decades of tried-and-true transducer design into each and every one of these, for the designer's piece of mind.

The 4mm square by 2mm high **SMT-0440-T-R** top-firing electro-mechanical transducer features a minimum SPL of 70 dBA at 10cm with only 3V (0-peak) input at 4 kHz.

Features:

- Ultra-small design for wearable devices
- High output in a small, lightweight package
- Pick-and-place and reflow compatible

Specifications

Parameters	Values	Units
Rated Voltage	3	Volts 0-peak
Operating Voltage Range	2 ~ 4	Volts 0-peak
Impedance	17 ± 3	Ohms
Minimum SPL (Rated voltage @ 10cm)	70	dBA
Resonant Frequency	4,000 ±500	Hz
Max Current Draw (Rated voltage, 50% duty cycle, at resonant frequency)	90	mA
Housing Material	LCP	-
Terminal Material	Tin-plated Brass	-
Weight	0.1	Grams
Operating Temperature	-20 ~ +70	°C
Storage Temperature	-30 ~ +80	°C

Measurement Method (3V0-p sine-sweep)

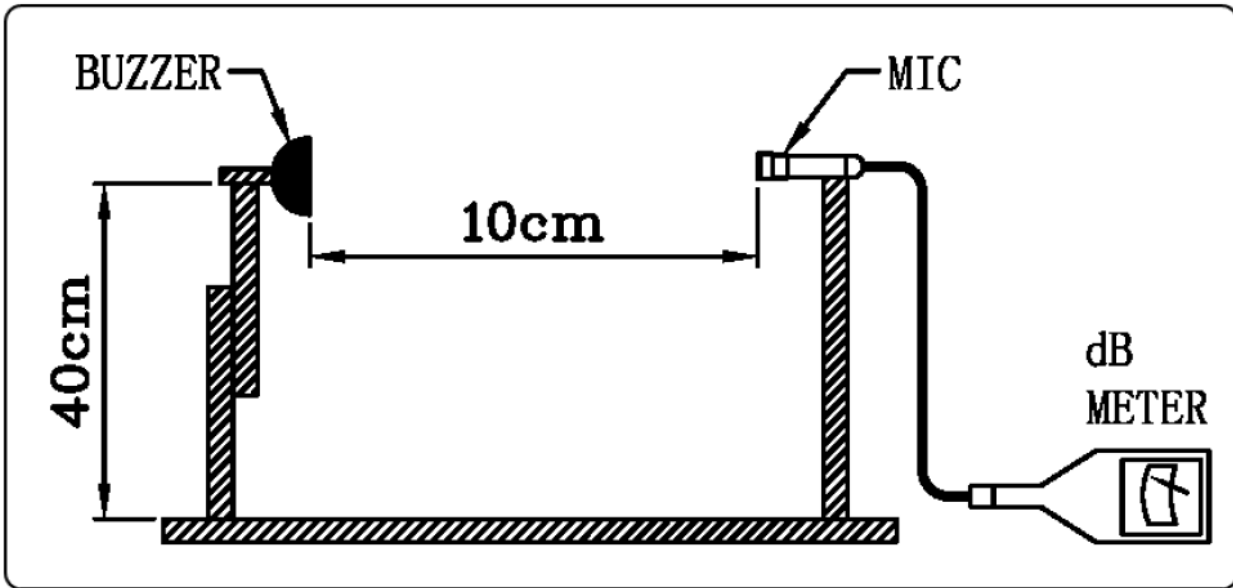

Frequency Response (measured with 3V0-p @ 10cm)

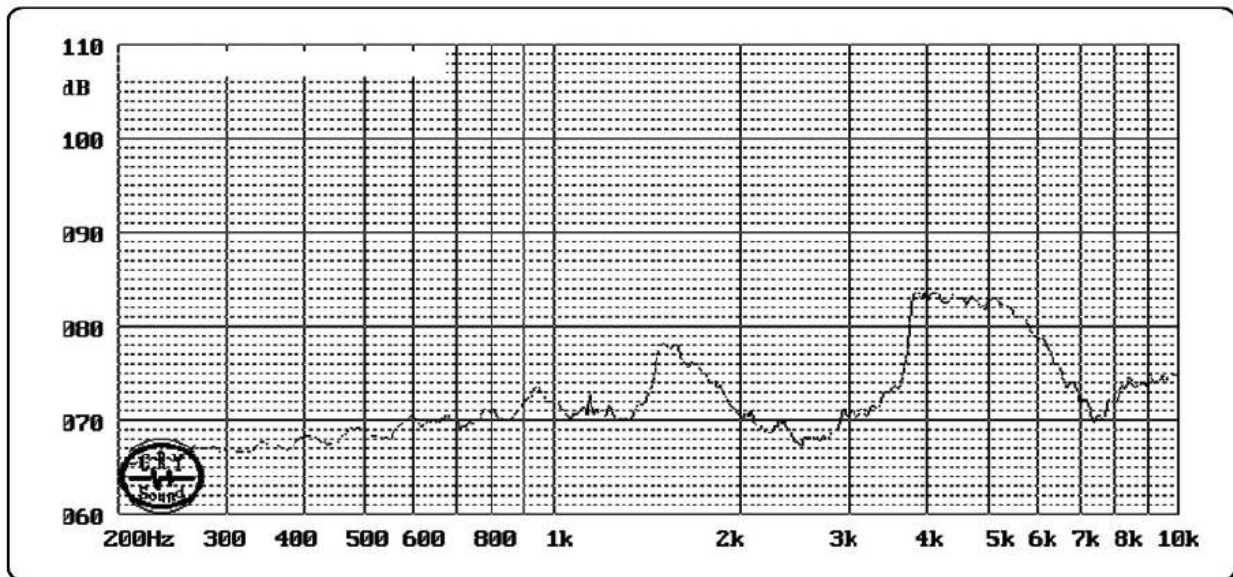

Recommended Drive Circuit

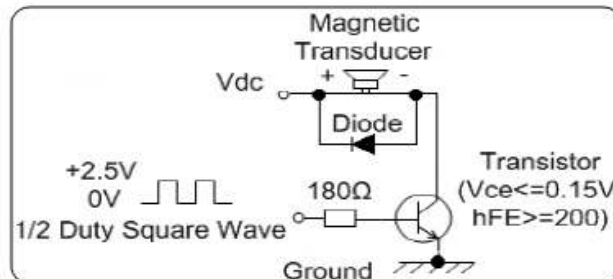

Recommended Reflow Profile

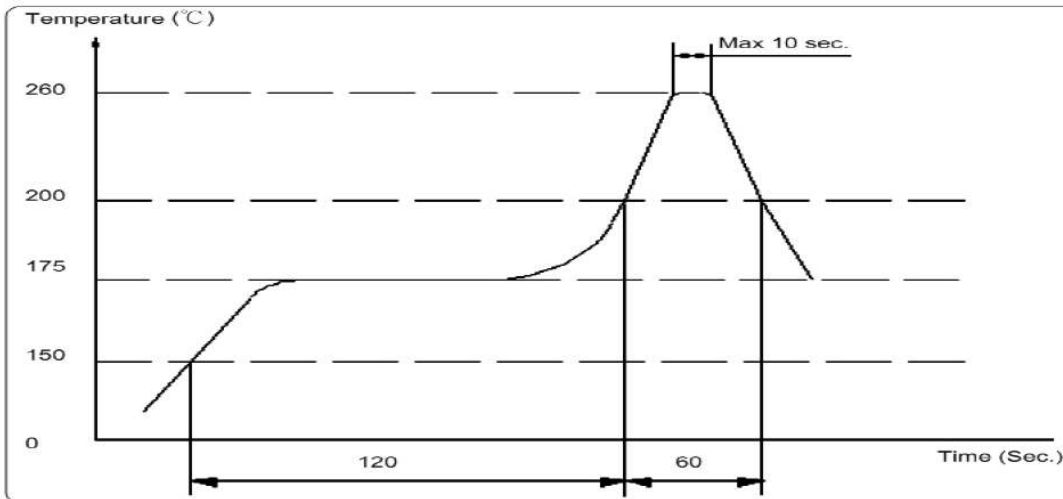

Reliability Testing

Type of Test	Test Specifications
High Temperature Test	96 hours at +70°C ± 2°C followed by two hours in normal room temperature
Low Temperature Test	96 hours at -20°C ± 2°C followed by two hours in normal room temperature
Humidity Test	25 ± 2 °C at 90-95% RH for 5 hr, then to 55 ± 2°C at 90-95% RH for 5hr, then to 25°C ± 2°C at 90-95% RH for 0.5hr, 10 cycles
Temperature Cycle Testing	The part shall be subjected to 5 cycles using the following procedure followed by two hours at room temperature:
Vibration Test	10 to 50 to 10 Hz in three perpendicular directions for two hours each.
Drop Test	Drop transducer from a 70cm height onto a 10mm thick wooden board in three directions.

After each test, the part's SPL, frequency response, and current draw shall meet specifications.

Dimensions

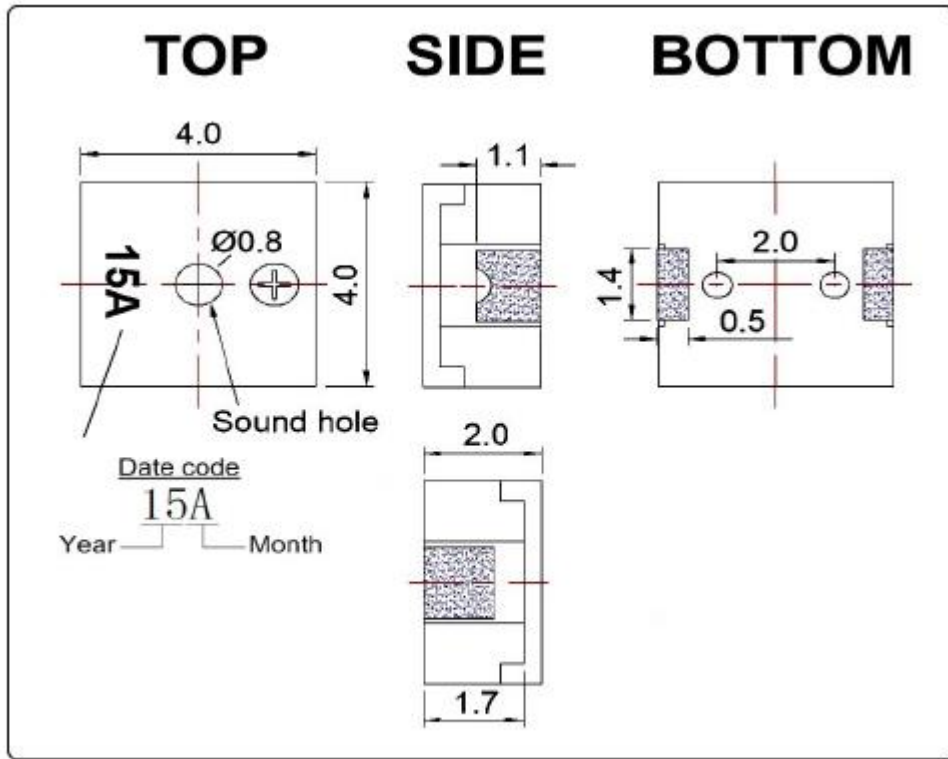

Tolerance: $\pm 0.5\text{mm}$ except specified

Recommended PCB Land Pattern

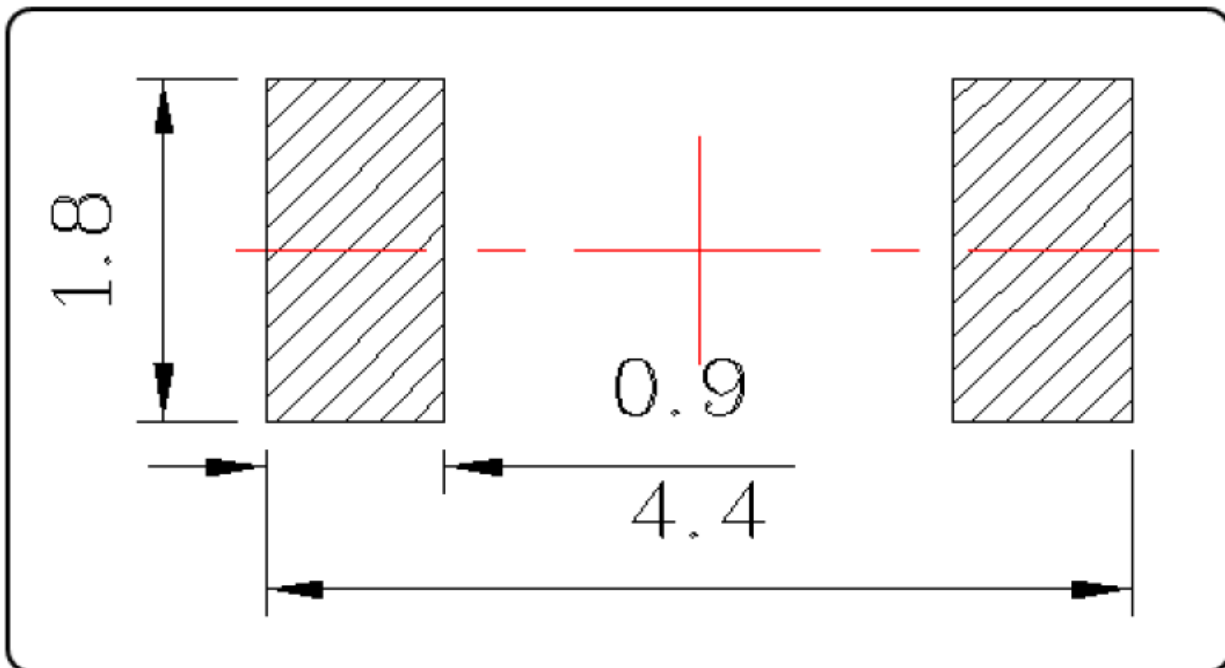

Packaging

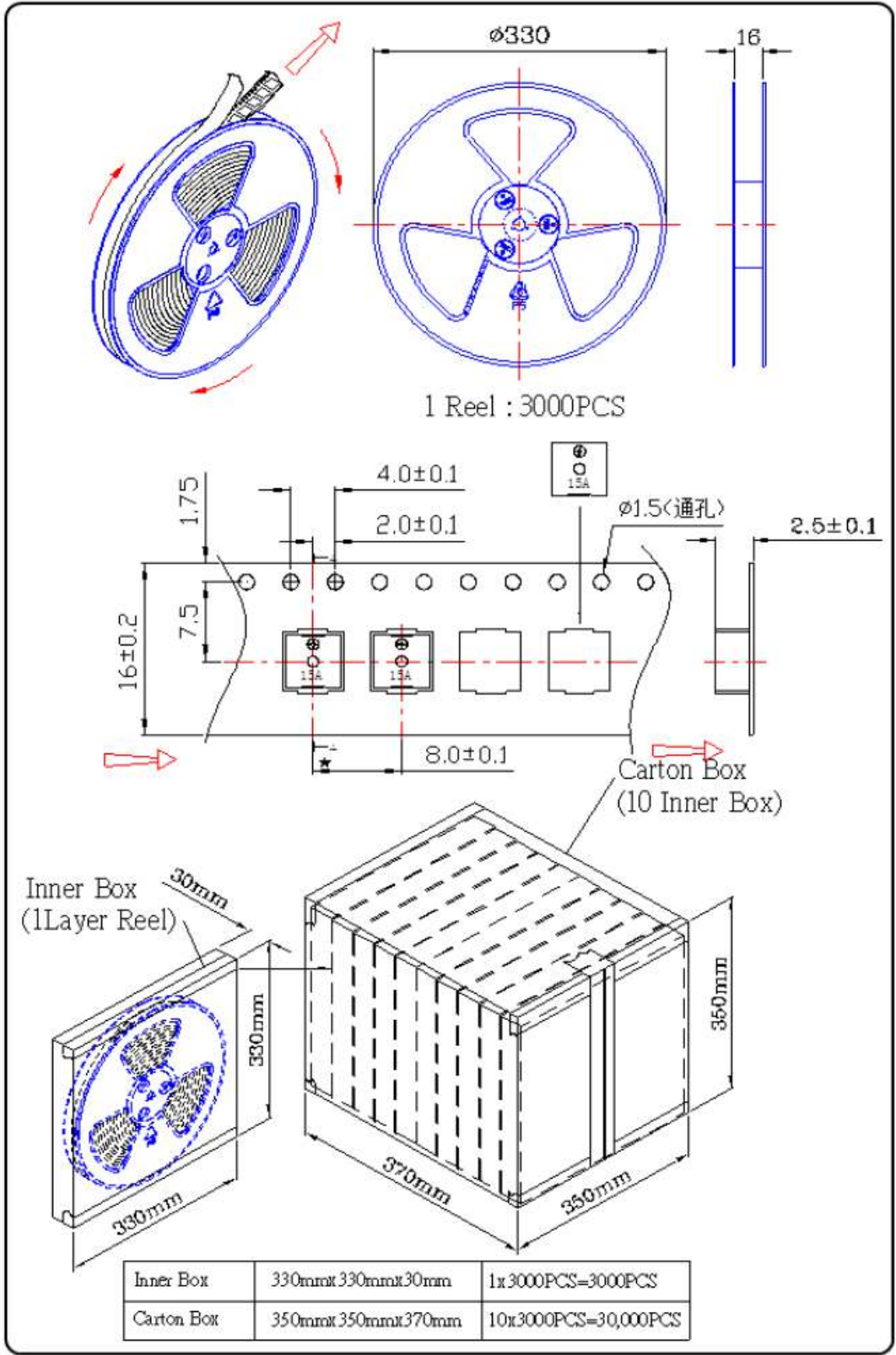

Specifications Revisions

Revision	Description	Date
-	Released from Engineering	11/06/2014

Note:

- 1. Unless otherwise specified:
 - A. All dimensions are in millimeters.
 - B. Default tolerances are $\pm 0.5\text{mm}$ and angles are $\pm 3^\circ$.
- 2. Specifications subject to change or withdrawal without notice.
- 3. This part is RoHS 2011/65/EU Compliant.