

ゲージ圧、差圧、絶対圧、3タイプ揃った空圧用圧カトランスジューサ

圧カトランスジューサ

PRESSURE TRANSDUCERS

P-3000S

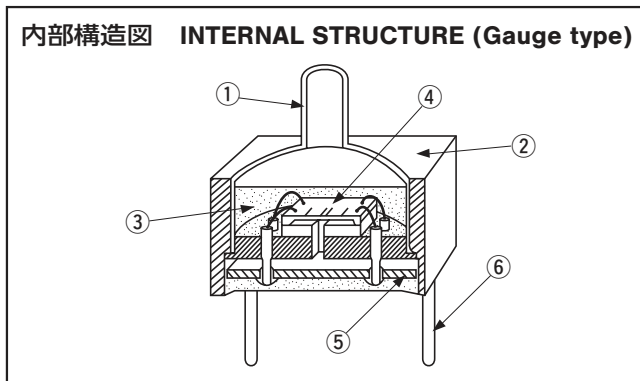
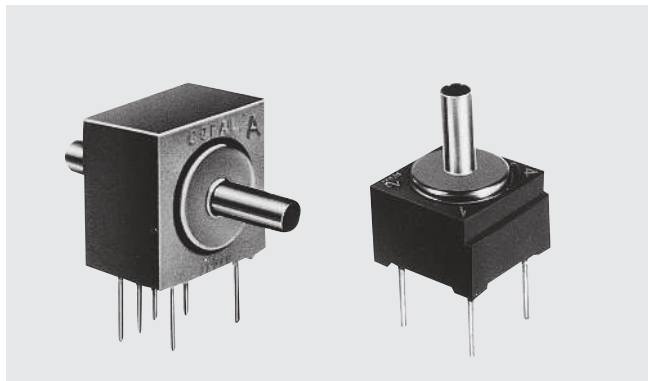

■特長 FEATURES

- 非腐食性気体用
- 温度補償機能内蔵 (0 ~ 50 °C)
- 3タイプの圧力指示方式 (ゲージ圧、差圧、絶対圧)
- 小型・軽量
- プリント基板搭載タイプ
- For non-corrosive gases
- Built-in temp. compensation function (0 ~ 50 °C)
- Three pressure reference to choose from Gauge, Differential and Absolute pressure
- Compact and light weight
- PC board mountable

名称 Part name	材料 Material
1 圧カポート Pressure port	鉄/ニッケル合金+ニッケルめっき Iron/Nickel alloy + Nickel-plated
2 ハウジング Housing	PBT (Polybutyleneterephthalate)
3 ポッティング Resin compound	シリコンゲル Silicone gel
4 センサチップ Sensor chip	シリコン単結晶 Silicone
5 温度補償抵抗基板 Resistor board for temp. compensation	セラミック Ceramic
6 リードピン Terminal pin	銅+はんだめっき Copper + solder-plated

■型式表示 MODEL NUMBER DESIGNATION

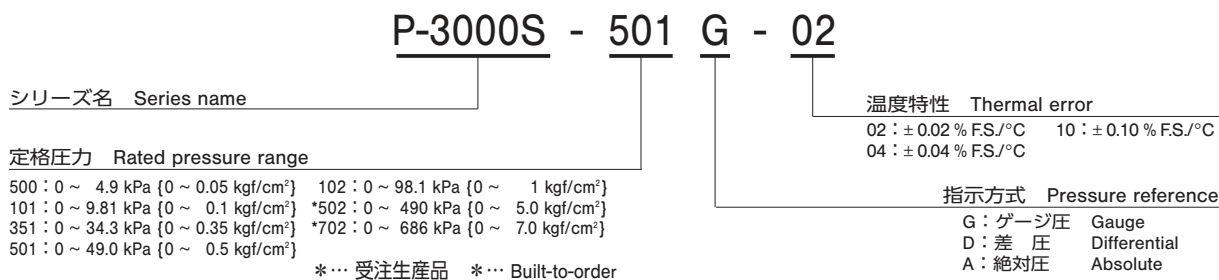

■型式一覧表 LIST OF MODEL NUMBERS

形 (指示方式) Pressure reference	ゲージ圧 Gauge						差圧 Differential			絶対圧 Absolute	
温度特性 Thermal error	0 ~ 4.9 {0 ~ 0.05}	0 ~ 9.81 {0 ~ 0.1}	0 ~ 49.0 {0 ~ 0.5}	0 ~ 98.1 {0 ~ 1}	0 ~ 490 {0 ~ 5.0}	0 ~ 686 {0 ~ 7.0}	0 ~ ±9.81 {0 ~ ±0.1}	0 ~ ±49.0 {0 ~ ±0.5}	0 ~ ±98.1 {0 ~ ±1}	0 ~ 34.3 {0 ~ 0.35}	0 ~ 98.1 {0 ~ 1}
± 0.02 % F.S./°C			P-3000S -501G-02	P-3000S -102G-02				P-3000S -501D-02	P-3000S -102D-02		
± 0.04 % F.S./°C	P-3000S -500G-04	P-3000S -101G-04	P-3000S -501G-04	P-3000S -102G-04	→P-3000S -502G-04	→P-3000S -702G-04	P-3000S -101D-04	P-3000S -501D-04	P-3000S -102D-04	P-3000S -351A-04	P-3000S -102A-04
± 0.1 % F.S./°C		P-3000S -101G-10	P-3000S -501G-10	P-3000S -102G-10			P-3000S -101D-10	P-3000S -501D-10	P-3000S -102D-10	P-3000S -351A-10	P-3000S -102A-10

☐ : 製作不可能 Not available

※ご注文に際しては、上記型式をご確認ください。 Verify the above model numbers when placing orders.

→印の型式は受注生産品です。お求めの際は個別にお問い合わせください。

The products marked → are built-to-order items. Please contact us separately to buy these products.

P-3000S

PRESSURE TRANSDUCERS

標準仕様 STANDARD SPECIFICATIONS

● 特記ない場合、周囲温度 25 ± 5℃、駆動電流 1.5 mA DC で規定します。
Unless otherwise specified, the specs are defined at an ambient temperature of 25±5 °C and excitation current of 1.5 mA DC.

項目 Item		型式 Model number	P-3000S										
			500G	101G	501G	102G	502G	702G	101D	501D	102D	351A	102A
一般仕様 General specifications	形 (指示方式) Pressure reference		ゲージ圧 Gauge					差圧 Differential			絶対圧 Absolute		
	定格圧力 Rated pressure range	kPa {kgf/cm ² }	4.9 {0.05}	9.81 {0.1}	49.0 {0.5}	98.1 {1.0}	490 {5.0}	686 {7.0}	± 9.81 {± 0.1}	± 49.0 {± 0.5}	± 98.1 {± 1.0}	34.3 (abs) {0.35}	98.1 (abs) {1.0}
	最大圧力 Maximum pressure	kPa {kgf/cm ² }	9.8 {0.1}	19.6 {0.2}	98.1 {1.0}	196 {2.0}	981 {10}	1372 {14}	19.6 {0.2}	98.1 {1.0}	196 {2.0}	103 (abs) {1.05}	196 (abs) {2.0}
	破壊圧力 Break-down pressure	kPa {kgf/cm ² }	24.5 {0.25}	49.0 {0.5}	245 {2.5}	490 {5.0}	1471 {15}	2058 {21}	49.0 {0.5}	245 {2.5}	490 {5.0}	147 (abs) {1.5}	490 (abs) {5.0}
	動作温度 Operating temp. range	°C	- 20 ~ 100										
	補償温度 Compensated temp. range	°C	0 ~ 50										
	動作湿度 Operating humidity	%RH	35 ~ 85 (結露しないこと No condensation)										
	保存温度 Storage temp.	°C	- 40 ~ 120 (大気圧、湿度 65 %RH 以下 Atmospheric pressure, humidity 65 %RH maximum)										
	ブリッジ抵抗 Bridge resistance	Ω	4700 ± 30 %										
	適用媒体 Pressure medium		非腐食性気体 Non-corrosive gases										
	絶縁抵抗 Insulation resistance	MΩ minimum	100 (50 V DC)										
	耐電圧 Dielectric strength		50 V AC, 60 s (リーク電流 1 mA 以下 Leakage current 1 mA maximum)										
	圧力ポート Pressure port	mm	φ 3.5										
	質量 Net weight	g	Approx. 5					Approx. 7			Approx. 5		
電源 Power	駆動電流 Excitation current	mA DC	1.5 (定電流 Constant current)										
アナログ出力 Analog output	オフセット電圧 Offset voltage	mV	± 3								± 5		
	スパン電圧 Span voltage	mV	70 ± 30	50 ± 20	100 ± 30			50 ± 20	100 ± 30		80 ± 40		
	直線性/ヒステリシス Linearity/Hysteresis	%F.S.	± 0.5	± 0.3	± 0.25			± 0.5	± 0.3		± 0.5		
	温度特性 Thermal error (基準温度 25 °C) (Reference temp.: 25 °C)	ZERO %F.S./°C	± 0.04	± 0.04/0.1	± 0.02/0.04/0.1			± 0.04	± 0.04/0.1	± 0.02/0.04/0.1		± 0.04/0.1	
		SPAN %F.S./°C	± 0.04	± 0.04/0.1	± 0.02/0.04/0.1			± 0.04	± 0.04/0.1	± 0.02/0.04/0.1		± 0.04/0.1	
応答速度 Response	ms	Approx. 1											

環境特性 ENVIRONMENTAL CHARACTERISTICS

試験項目 Test item	試験方法 (条件 25 ± 5 °C) Test conditions (At 25 ± 5 °C)	変動量 Permissible change
振動 Vibration	10 ~ 500 Hz, 1.5 mm maximum/98.1 m/s ² , 3 directions for 2 hours each	オフセット電圧/スパン電圧 それぞれ最大 ± 1 %F.S. Offset voltage/Span voltage: ± 1 %F.S. maximum each
衝撃 Shock	981 m/s ² , 3 directions for 3 times each	
圧力サイクル Pressure cycling	0 ~ 定格圧力 0 ~ Rated pressure, 10 ⁶ cycles	
耐湿性 Moisture resistance	40 °C, 90 ~ 95 %RH, 240 hrs.	

※負圧でもご使用は可能ですが、精度保証するものではありません。精度保証が必要な場合は、個別にお問い合わせください。
The sensor can measure vacuum pressure, however its accuracy isn't always guaranteed.
If you need guarantee of accuracy Contact us separately.

P-3000S

PRESSURE TRANSDUCERS

外形寸法図 OUTLINE DIMENSIONS

Unless otherwise specified, tolerance : ± 0.5 (Unit: mm)

- ゲージ圧タイプ
絶対圧タイプ
Gauge
Absolute type

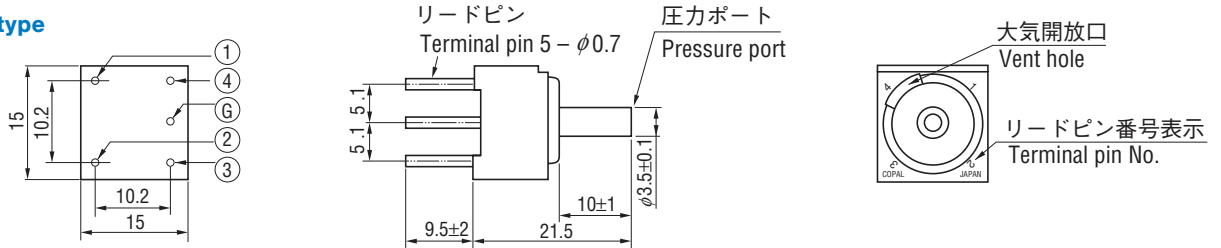

- 差圧タイプ
Differential type

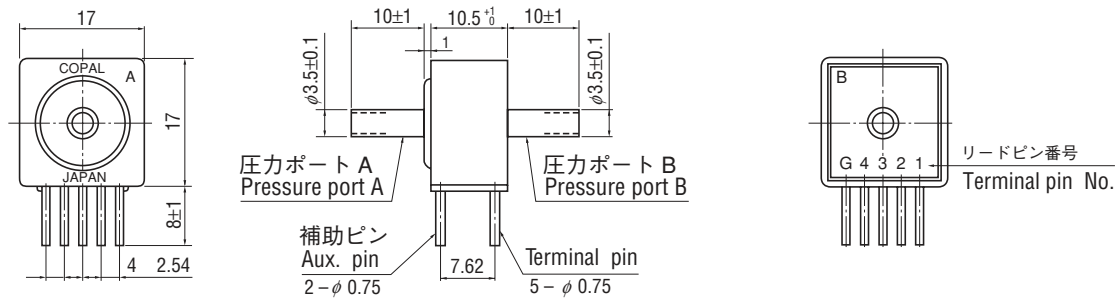

内部電気回路 INTERNAL ELECTRICAL SCHEMATICS

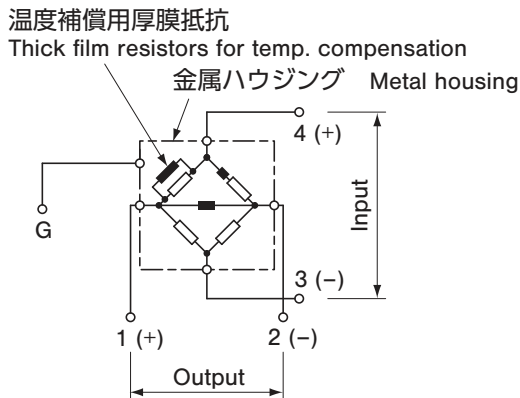

端子番号 TERMINAL NUMBER

Pin	Connection
1	Output \oplus
2	Output \ominus
3	Input \ominus
4	Input \oplus
G	Housing