

# TDK SMD MULTI WINDING TRANSFORMER PCA 14.5/6ER SERIES

**Mechanical**

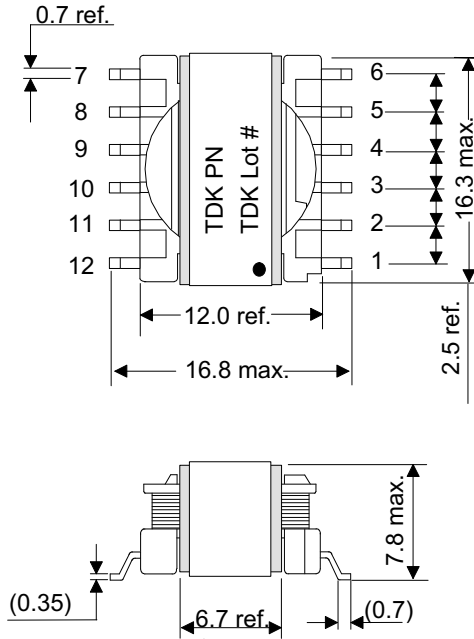

**Schematic**

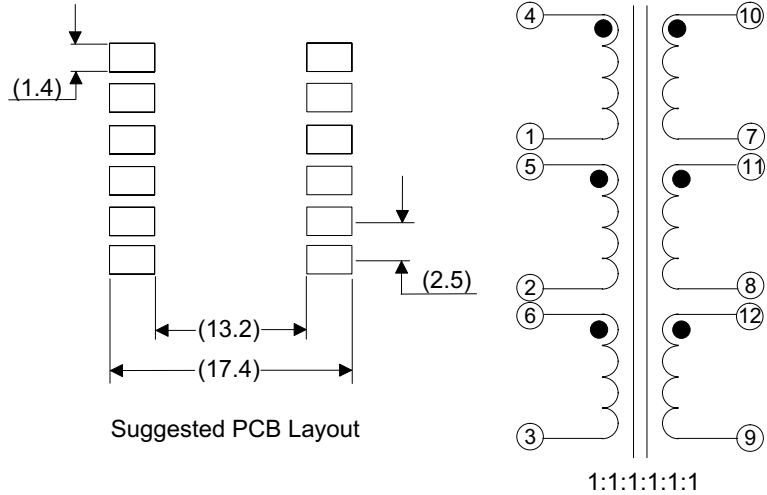

TDK Part Number	Inductance uH @ 10KHz, 0.1 Vrms.		*1 Idc 1 Amps (Typ.)		*2 Idc 2 Amps (Typ.)		DCR m Ohms (±15%)		ET Constant V-µS (Max.)		Leakage Inductance nH (Typ.)
	*3 Parallel	*4 Series	*3 Parallel	*4 Series	*3 Parallel	*4 Series	*3 Parallel	*4 Series	*3 Parallel	*4 Series	Single
PCA14.5/6ER-U01S002	160.0±30%	5.8mH±30%	0.2	0.03	5.9	0.98	18.0	662	53.0	317	120
PCA14.5/6ER-U02S002	78.4±30%	2.8mH±30%	0.3	0.04	7.9	1.32	9.8	356	37.0	222	103
PCA14.5/6ER-U03S002	21.6±20%	778±20%	3.1	0.52	5.9	1.00	18.0	662	53.0	317	120
PCA14.5/6ER-U04S002	10.6±20%	381±20%	4.8	0.80	7.9	1.32	9.8	356	37.0	222	103
PCA14.5/6ER-U05S002	11.6±20%	418±20%	6.5	1.08	5.9	1.00	18.0	662	53.0	317	120
PCA14.5/6ER-U06S002	5.7±20%	205±20%	8.8	1.46	7.9	1.32	9.8	356	37.0	222	103
PCA14.5/6ER-U07S002	8.3±20%	299±20%	9.6	1.60	5.9	1.00	18.0	662	53.0	317	120
PCA14.5/6ER-U08S002	4.1±20%	146±20%	14.3	2.38	7.9	1.32	9.8	356	37.0	222	103
PCA14.5/6ER-U09S002	6.6±20%	238±20%	12.5	2.08	5.9	1.00	18.0	662	53.0	222	120
PCA14.5/6ER-U10S002	3.2±20%	116±20%	17.5	2.92	7.9	1.32	9.8	356	37.0	317	103

**Electrical Specifications @ 23 degrees C**

- \*1 Idc 1 = Depend on inductance saturation . (-30% reduction from nominal L value)
- \*2 Idc 2 = Depend on self temperature rise. (40 degC typ at specified Idc2)
- \*3 Parallel 6 coils connected in parallel.
- \*4 Series 6 coils connected in series.
- Hi - Pot between each individual coil to the other five 500 Vac, 60s, 2mA.
- Operating Temperature -40 degC to +85 degC.

RoHS Compliant :  
Conformity to RoHS Directive: This means that, in conformity with EU Directive 2002/95/EC, cadmium, mercury, hexavalent chromium, and specific bromine-based flame retardants, PBB and PBDE, have not been used except for exempted applications.



TDK USA Corporation / Component Engineering Laboratory