



The ultra-low-profile DDR3 DIMM sockets deliver greater vertical space and power savings for ATCA* blade systems and other networking devices using high-density memory modules

DDR3 is an established DDR DRAM interface technology that offers more bandwidth and higher performance at lower power for demanding memory applications in desktop PCs, servers and notebook computers. It finds expanding use for high-performance embedded systems in telecommunication, networking and storage systems, advanced computing platforms and industrial controls. DDR3 supports data rates of 800 to 1600 Mbps with clock frequencies of 400 to 800 MHz (respectively); effectively doubling the speed of DDR2. With a standard operating voltage of 1.5V, DDR3 cuts power consumption of DDR2 by up to 30%.

A leading manufacturer of internal memory module sockets, Molex produces Ultra-Low-Profile DDR3 DIMM sockets to support unregistered DDR3 DIMMs as well as Registered DIMMs (RDIMMs). These sockets feature a low-level contact resistance of only 10milliohms, reducing overall power consumption in data systems.

With a seating plane of only 1.10mm – the lowest known in the industry – the sockets provide optimum design flexibility by allowing the use of very low-profile memory modules with seating heights below 2.80mm (maximum) in ATCA blade systems. For applications requiring conformance to ATCA Board Mechanics Specifications where component heights cannot exceed 21.33mm from ‘side 1 of the front board PCB’ (specification definitions), these sockets are excellent as they free up to 20.23mm of vertical space above the PCB for the mounting of high-density DIMMs.

The sockets’ reduced latch-actuation angles use less PCB real-estate than standard DIMM sockets to enable the addition of neighbouring components. The ultra-low-profile DIMM sockets also have a smaller overall (7.40 by 155.00mm) real estate than that according to JEDEC Specifications (7.75 by 165.00mm), making them space-savers for complex base stations, server farms and voice gateways where chassis mechanics, power, thermal and airflow conditions are critical design factors.

The sockets have glass-filled, high-temperature Nylon housing that enable wave soldering and high-temperature IR reflow operations. The socket latches are reinforced with metal to provide robust module retention and ejection. They also ensure module ejection forces of no less than those in 2.40 or 3.30mm seating plane sockets. Available in black or white parts, the sockets are halogen-free.

For more information, visit our website at: www.molex.com/link/ddr3.html.

Features and Benefits

Ultra-low seating plane of 1.10mm height	Frees up vertical module space to allow use of high-density DIMMs while maintaining the same design height; Enables the use of very low-profile modules with seating heights below 2.80mm (maximum) in ATCA* blade systems
Low-level contact resistance of 10milliohms (maximum initial)	Supports the use of Registered DIMM (RDIMM) modules and reduces power consumption in blade servers
Reduced latch-actuation angle	Creates more room for neighbouring components while improving airflow space around memory module socket
High-temperature, glass-filled socket housing and latches	Provides robust module retention and ejection; able to withstand wave solder and IR reflow temperatures
Compliance with industry-standard specifications	Accepts JEDEC MO-269 memory modules

*The Advanced Telecom Computing Architecture (AdvancedTCA or ATCA) specifications, denoted PICMG † 3.X, are a series of PICMG specifications, targeted to requirements for the next generation of ‘carrier grade’ communications equipment. This series of specifications incorporates the latest trends in high-speed interconnect technologies, next-generation processors and improved reliability, manageability and serviceability.

†PCI Industrial Computer Manufacturers Group 3.0 specification defines open architecture modular computing components that can be quickly integrated to deploy high-performance services solutions.

Ultra-Low-Profile DDR3 DIMM Sockets

78588 1.10mm Seating Plane, Low-Level Contact Resistance (LLCR), Through Hole, Vertical, 240 circuits Halogen-free, Lead-free

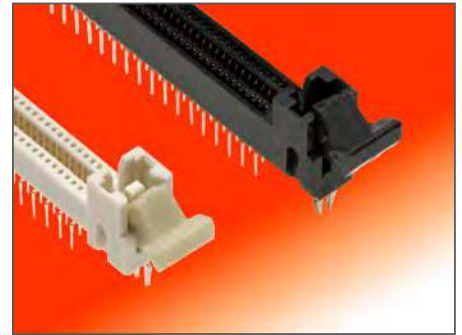

The ultra-low-profile DDR3 DIMM socket (left) has a lower seating-plane than standard DDR3 DIMM versions (right)

Specifications

Reference Information

Packaging: Tray
 UL File No.: E-29179
 CSA File No.: 1699020 (LR19980)
 Use With:
 JEDEC MO-269 memory modules
 Designed In: mm
 RoHS: Yes
 Halogen Free: Yes
 Glow Wire Compliant: No

Electrical

Voltage (max.):
 29 Volts AC (RMS) / DC
 Voltage Key Positions: Centre. 1.5V
 Current (max.): 1.0 Amps per pin
 Low Level Contact Resistance (max.):
 10 milliohms (initial)
 Dielectric Withstanding Voltage:
 500 VAC
 Insulation Resistance (min.):
 1 megaohm

Mechanical

Module Insertion Force
 (with latches):
 10.8 kgf (106N) max.
 Terminal Retention Force (min.):
 Contact: 0.25kgf (2.5N)
 Fork lock: 1.36kgf (13.3N)
 Latch Actuation Force (to open):
 4.5kgf (10lbs) max. per latch
 Module Rip-out Force at center
 (without damage):
 9.1kgf (20lbs) min.
 PCB Retention Force: 0.45kgf (4.4N)
 Durability: 25 cycles

Physical

Housing:
 High temperature Nylon,
 glass-filled, UL94-V0
 Terminal: Copper Alloy
 Soldertail length: 3.18mm
 Plating:
 Contact Area —
 Refer to table below
 Solder Tail Area —
 2.54µm (100µ") pure Matte Tin (Sn)
 Underplating —
 1.27µm (50µ") Nickel (Ni)
 PCB Thickness: 2.36mm
 Operating Temperature: -55 to +85°C

Additional Features

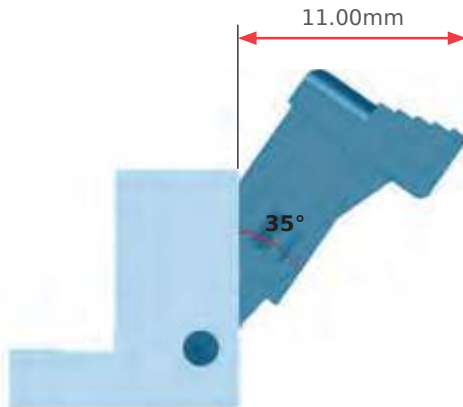

Standard latch-actuation design showing larger latch angle and correspondingly greater real estate needed for socket

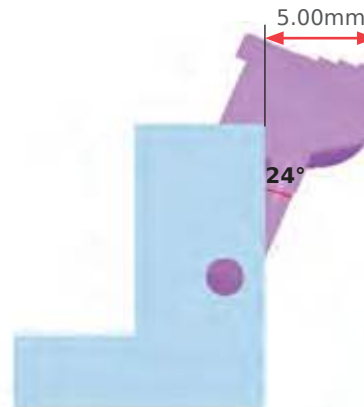

Smaller angular latch-actuation design of Ultra-Low-Profile DDR3 DIMM socket corresponds to a smaller PCB real estate

A smaller latch angle frees up valuable PCB real estate for situation of more electronic components in the vicinity

Applications

Data/Network/Telecom

- Desktop PCs
- Servers
- Workstations
- Routers
- Switches
- Storage systems
- Base stations
- Server farms
- Voice gateways

Industrial

- Programmable logic systems

Medical

- Advanced imaging devices



Typical applications of Ultra-Low-Profile DDR3 DIMM Sockets

Ordering Information

Order No.	Housing Color	Latch Color	Plating (Contact Area)
78588-0002	Black	Black	0.76µm (30µ") Gold (Au)
78588-1502			0.38µm (15µ") Gold (Au)
78588-1552		Natural (off-white)	
78588-1562	Natural (off-white)		