

SECTION X-X
INSULATION BARREL
SCALE 20:1

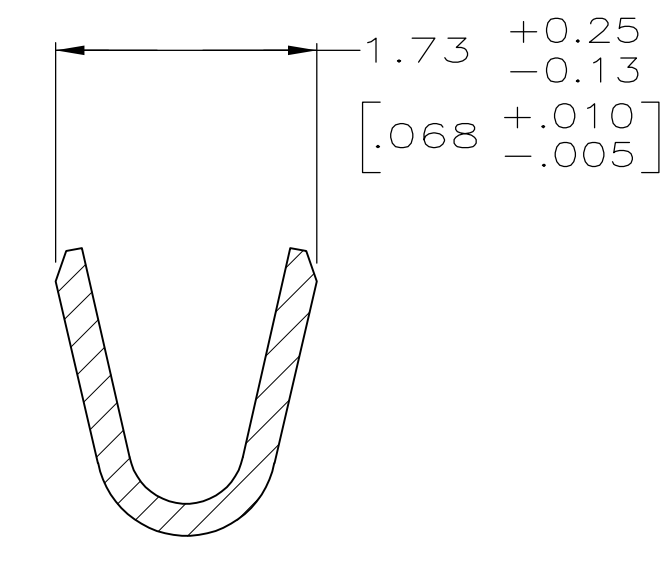

SECTION Y-Y
WIRE BARREL
SCALE 20:1

- 1 FOR MINI-APPLICATOR AND STRIPPER CRIMPER.
- 2 FOR HAND TOOL USE ONLY.
- 3 FOR STANDARD APPLICATOR PART #566171 ONLY.
- 4. WIRE RANGE OF 20-24 AWG. INSULATION RANGE OF 1.27/1.52 [.050-.060].
- 5. GOLD PLATING MAY NOT APPEAR ON CARRIER STRIP. NICKEL UNDERPLATE COVERS ENTIRE CONTACT.
- 6 GOLD PLATING PER MIL-G-45204. NICKEL PLATING PER QQ-N-290. TIN PLATING PER MIL-T-10727. COPPER PLATING PER MIL-C-14550.
- 7 PLATED, 1.27µm [.000050] MIN GOLD ON LOCALIZED GOLD PLATE AREA AND ZONE 1 OVER 1.27µm [.000050] MIN NICKEL.
- 8 GOLD PLATED IN LOCALIZED GOLD PLATE AREA AS FOLLOWS:
0.76µm [.000030] MIN GOLD IN MATED AREA, GOLD FLASH ON REMAINDER OF LOCALIZED GOLD PLATE AREA AND ZONE 1 OF CONTACT, ALL OVER 1.27µm [.000050] MIN NICKEL UNDERPLATE.
OR
GOLD FLASH OVER PALLADIUM-NICKEL PLATE, 0.76µm [.000030] MIN TOTAL IN MATED AREA, GOLD FLASH ON REMAINDER OF LOCALIZED GOLD PLATE AREA AND ZONE 1 OF CONTACT, ALL OVER 1.27µm [.000050] MIN NICKEL UNDERPLATE.
- 9 PLATED WITH GOLD FLASH ON LOCALIZED GOLD PLATE AREA AND ZONE 1 OVER 0.76µm [.000030] MIN NICKEL.
- 10 PLATED WITH 2.54µm - 5.08µm [.000100 - .000200] TIN.
- 11 GOLD PLATED IN LOCALIZED GOLD PLATED AREA, 0.76µm [.000030] GOLD IN MATED AREA, TIN PLATED WIRE BARRELS, OVER 1.27µm [.000050] NICKEL.
- 12 PLATED WITH GOLD FLASH IN LOCALIZED GOLD PLATE AREA, TIN PLATED WIRE BARRELS, OVER 0.76µm [.000030] NICKEL.
- 13 GOLD PLATED IN LOCALIZED GOLD PLATE AREA, 0.38µm [.000015] GOLD IN MATED AREA, GOLD FLASH ON REMAINDER, OVER 1.27µm [.000050] NICKEL.
- 14 AMP ITALY PART NUMBER ONLY.
- 15 GOLD PLATED IN LOCALIZED GOLD PLATE AREA, 1.27µm [.000050] GOLD IN MATED AREA, GOLD FLASH ON REMAINDER, OVER 1.27µm [.000050] NICKEL.
- 16 GOLD PLATED IN LOCALIZED GOLD PLATE AREA, 0.03µm [.000001] GOLD IN MATED AREA, 0.76µm [.000030] MIN TIN PLATED WIRE BARRELS, ALL OVER 0.76µm [.000030] MIN NICKEL.
- 17 GOLD FLASH IN LOCALIZED GOLD PLATE AREA, 2.54µm [.000100] MIN TIN OR TIN-LEAD PLATED WIRE BARRELS, ALL OVER 0.76µm [.000030] MIN NICKEL.
- 18 COMPANY LOGO ON BOTTOM OF EITHER WIRE OR INSULATION BARRELS.

SUPERSEDED BY	STANDARD	5.84 [.230]	1.27	1	STRIP	6-66506-4
OBSOLETE	STANDARD	3.94 [.155]	1.27	3	STRIP	6-66506-3
OBSOLETE	STANDARD	3.94 [.155]	1.27	1	STRIP	6-66506-2
	SMALL PACK	3.94 [.155]	1.27	1	LOOSE PIECE	6-66506-1
OBSOLETE	STANDARD	3.94 [.155]	1.27	1	STRIP	6-66506-0
OBSOLETE	STANDARD	3.94 [.155]	1.27	1	LOOSE PIECE	5-66506-9
OBSOLETE	STANDARD	3.94 [.155]	1.27	2	LOOSE PIECE	5-66506-7
OBSOLETE	STANDARD	3.94 [.155]	1.27	1	STRIP	2-66506-5
OBSOLETE	STANDARD	3.94 [.155]	1.27	1	STRIP	2-66506-4
OBSOLETE	STANDARD	-	1.02	1	STRIP	1-66506-4
OBSOLETE	STANDARD	-	1.02	1	STRIP	1-66506-1
	STANDARD	-	1.02	2	LOOSE PIECE	1-66506-0
	STANDARD	3.94 [.155]	1.27	2	LOOSE PIECE	66506-9
	STANDARD	-	1.02	2	LOOSE PIECE	66506-8
	STANDARD	-	1.02	1	STRIP	66506-4
	STANDARD	3.94 [.155]	1.27	1	STRIP	66506-3
	STANDARD	-	1.02	1	STRIP	66506-2
PACKAGING TYPE	B	FINISH	USE	TYPE	PART NUMBER	

THIS DRAWING IS A CONTROLLED DOCUMENT. DIMENSIONING AND TOLERANCING PER ASME Y14.5M-2009

DIMENSIONS: mm [INCHES]	TOLERANCES UNLESS OTHERWISE SPECIFIED:	DIN S. WELDON 9-9-86	TE Connectivity
0 PLC ± -	1 PLC ± -	CIK C. RICHARD 9-9-86	
2 PLC ± 0.13 [.005]	3 PLC ± -	APVD V. KUMAR 9-10-86	NAME
4 PLC ± -	ANGLES ± -	APPLICATION SPEC	PIN CONTACT, SIZE 20 DF, 20-24 AWG, AMPLIMITE
MATERIAL BRASS	FINISH	114-10000	SIZE
		WEIGHT	CAGE CODE
		CUSTOMER DRAWING	DRAWING NO
		SCALE 10:1	REV