

Digilent Pro MX7 Board Reference Manual

Revised June 29, 2017

This manual applies to the Digilent Pro MX7 rev. B and C

Overview

Digilent Pro MX7 is the new name for Cerebot MX7. This board retains all functionality of the Cerebot MX7.

The Digilent Pro MX7 is a microcontroller development board based on the Microchip® PIC32MX795F512L, a member of the 32-bit PIC32 microcontroller family. It is compatible with Digilent's line of peripheral modules, Pmod™, and is suitable for use with the Microchip MPLAB® IDE tools. The Digilent Pro MX7 is also compatible for use with MPIDE development environment. MPIDE is a PIC32-based system compatible with many existing Arduino® code examples, reference materials, and other resources.

The Digilent Pro MX7 is designed to be easy to use and suitable for use by anyone from beginners to advanced users experimenting with embedded control and network communications application. A built-in programming/debugging circuit compatible with the Microchip MPLAB IDE is provided, so no additional hardware is required for use with MPLAB. The kit contains everything needed to start developing embedded applications using either the MPLAB IDE or the MPIDE.

The Digilent Pro MX7 provides 52 I/O pins that support a number of peripheral functions, such as UART, SPI, I²C™ ports, as well as five pulse-width modulated outputs and five external interrupt inputs. Its network and communications features also include a 10/100 Ethernet interface, Full Speed USB 2.0 OTG interface, and dual CAN network interfaces. Ten of the I/O pins can be used as analog inputs in addition to their use as digital inputs and outputs.

The Digilent Pro MX7 can be powered in various ways via USB, or using an external AC-DC power adapter.

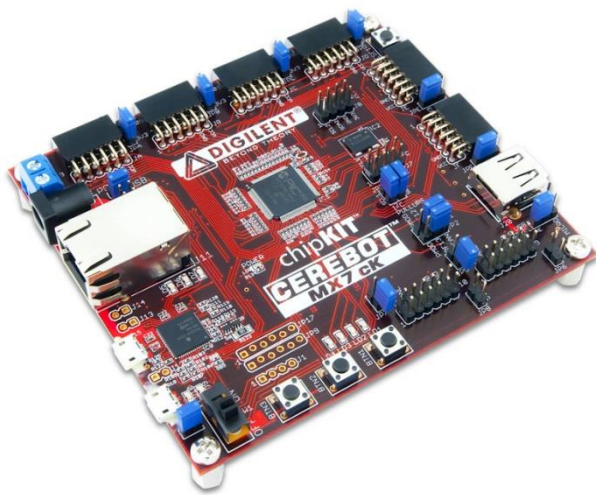

Digilent Pro MX7 board.

Features of the Digilent Pro MX7 include:

- PIC32MX795F512L microcontroller
- Support for programming and debugging within the Microchip MPLAB development environment
- Support for programming within the MPIDE development environment
- Six Pmod ports for Digilent peripheral module boards
- 10/100 Ethernet
- USB 2.0 compatible Device, Host, and OTG support
- Two CAN network interfaces
- Three push buttons
- Four LEDs
- Multiple power supply options, including USB powered
- ESD protection and short circuit protection for all I/O pins.

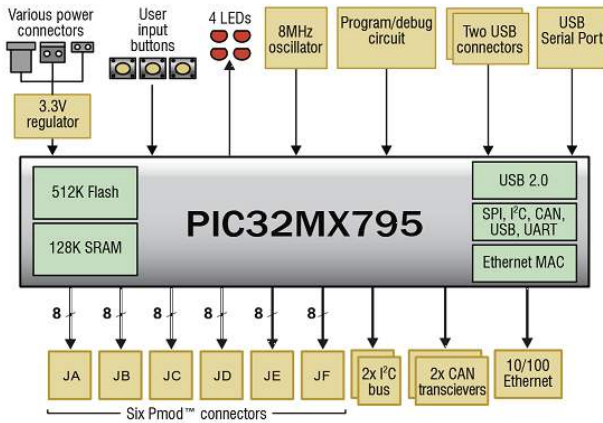

Digilent Pro MX7 Circuit Diagram

Features of the PIC32MX795F512L include:

- 512KB internal program flash memory
- 128KB internal SRAM memory
- USB 2.0 compliant full-speed On-The-Go (OTG) controller with dedicated DMA channel
- 10/100 Ethernet controller
- Two CAN network controllers
- Up to four serial peripheral interfaces (SPI)
- Up to six UART serial interfaces
- Up to four I2C serial interfaces
- Five 16-bit timer/counters
- Five timer capture inputs
- Five compare/PWM outputs
- Sixteen 10-bit analog inputs
- Two analog comparators

Functional Description

The Digilent Pro MX7 is designed for embedded control and network communications applications as well as general microprocessor experimentation. Firmware suitable for many applications can be downloaded to the Digilent Pro MX7's programmable PIC32 microcontroller.

The Digilent Pro MX7 has a number of input/output connection options, and is designed to work with the Digilent line of Pmods that provide various input and output functions. For more information, visit www.digilentinc.com. In addition to the Pmod ports, the board provides three push buttons and four LEDs for user I/O, as well as providing connections for two I²C busses. A serial EEPROM is provided on one of the I²C busses.

The Digilent Pro MX7 features a flexible power supply system with a number of options for powering the board as well as powering peripheral devices connected to the board. It can be USB powered via the debug USB port, the USB UART serial port, or the USB device port. It can also be powered from an external 5V power supply.

1 Programming Tools

The Digilent Pro MX7 can be used with either the Microchip MPLAB development environment or the MPIDE development environment. When used with the MPLAB[®] IDE, in-system-programming and debugging of firmware running on the PIC32MX795 microcontroller is supported using an on-board programming/debugging circuit licensed from Microchip.

The Digilent Pro MX7 is immediately useable with either the MPLAB IDE or the MPIDE. No additional hardware is required to use the board with the Microchip MPLAB tools.

1.1 Using the Digilent Pro MX7 with Microchip Development Tools

The Microchip MPLAB IDE or the MPLAB X IDE can be used to program and debug code running on the Digilent Pro MX7 board using the built-in programming/debugging circuit.

The MPLAB development environment can be downloaded from the Microchip website. This software suite includes a free evaluation copy of the Microchip C32 compiler for use with the PIC32 microcontroller family. The licensed debugger is compatible with the MPLAB IDE version 8.63 or later, or all versions of MPLAB X.

When creating a new project, use the "Configure.Select Device..." menu to specify the PIC32 device being used. Ensure that the device is set to PIC32MX795F512L.

In order to use the on-board programming/debugging circuit, it must be selected as the debugger or programmer within the MPLAB IDE. Use the "Debugger.Select Tool" menu, or the "Programmer.Select Tool" menu, and select "Licensed Debugger" as the programmer or debugger.

The licensed debugger interface uses USB connector J15, labeled DEBUG. Connector J15 is a USB micro-B connector located on the left side of the board below the Ethernet RJ45 connector. Use a USB-A to micro-B cable (provided with the board) to connect to an available USB port on the PC.

When the licensed debugger is selected as the programming or debugging device, the MPLAB IDE will check the version number of the firmware running on the debugger and offer to update if it is out of date with the version of MPLAB being used.

The PIC32 in-system programming/debugging interface uses two pins on the microcontroller. These devices support two alternate pin pairs for this interface: PGC1/PGD1 or PGC2/PGD2. The PGC2/PGD2 pair is used by default. Due to conflicting uses of the microcontroller pins, the Digilent Pro MX7 is designed to use the PGC1/PGD1 pair of pins. Because of this, it is necessary to select the use of PGC1/PGD1 for the debugging interface. This is done using configuration variables set using the `#pragma config` statement. The following statement must be used to configure the microcontroller for use with the on-board licensed debugger circuit:

```
#pragma config ICESEL = ICS_PGx1
```

The MPLAB IDE may report an error indicating that the device is not configured for debugging until a program containing this statement has been programmed into the board.

The MCLR pin on the PIC32 microcontroller is used by the hardware programming/debugging interface to reset the processor. This same pin is used by the USB serial converter to reset the processor when using the MPIDE. It is possible that the reset function from the USB serial interface can interfere with correct operation of the Microchip programming and debugging tools. If this happens, jumper JP11 can be used to disconnect the USB serial converter reset circuit. Remove the shorting block from JP11 to disable the reset circuit. If the shorting block has been removed, it is necessary to reinstall it on JP11 in order to use the Digilent Pro MX7 board with the MPIDE again.

Using the Microchip development tools to program the Digilent Pro MX7 will erase the boot loader. To use the board with the MPIDE again, it is necessary to program the boot loader back onto the board. The programming file for the boot loader programmed into the board by Digilent at the factory is available for download from the product page for the Digilent Pro MX7 on the Digilent web site. Additionally, the boot loader source code is available in the chipKIT project repository at www.github.com/chipKIT32/pic32-Arduino-Bootloader.

To reprogram the boot loader using MPLAB, perform the following steps:

- Use the "Configure.Select Device ..." menu to select the PIC32MX795F512L
- Use the "Programmer.Select Programmer" menu to select the "Licensed Debugger".

- Use the "File Import..." dialog box to navigate to and select the boot loader programming downloaded from the Digilent web site. The file name will be something like: chipKIT_Bootloader_MX7.hex
- Use the "Programmer.Program" command to program all memories on the device.

1.2 Using the Digilent Pro MX7 with the MPIDE

MPIDE is a PIC32 based hardware and software system compatible with many existing Arduino™ code examples, reference materials, and other resources. The MPIDE development platform was produced by modifying the Arduino™ IDE and is fully backward compatible with the Arduino IDE. The Digilent Pro MX7 board is designed to be fully compatible with the MPIDE system, version 20111221 or later.

The MPIDE uses a serial communications port to communicate with a boot loader running in the target board. The serial port on the MX7 board is implemented using an FTDI FT232R USB serial converter. Before attempting to use the MPIDE with the MX7, the appropriate USB device driver must be installed.

The USB serial converter on the Digilent Pro MX7 uses USB connector J2, labeled UART on the board. This connector is a USB micro-AB, and is located on the lower left side of the board adjacent to the power switch. Use a standard USB-A to micro-B cable (provided with the board) to connect the board to an available USB port on the PC.

In the MPIDE, use the "Tools.Board" command to select the Digilent Pro MX7 from the list of available boards. Use the "Tools.Serial Port" command to choose the appropriate serial port from the list of available serial ports on the PC.

When the MPIDE needs to communicate with the MX7 board, the PIC32 microcontroller is reset and starts running the boot loader. The MPIDE then establishes communications with the boot loader and downloads the user's program, programming it into the flash memory in the microcontroller .

When the MPIDE opens the serial communications connection on the PC, the DTR pin on the FT232R chip is driven low. This pin is coupled through a capacitor to the MCLR pin on the PIC32 microcontroller. Driving the MCLR line low resets the microcontroller, restarting execution with the boot loader.

The automatic reset action when the serial communications connection is opened can be disabled. To disable this operation, remove the shorting block from jumper JP11. The shorting block is reinstalled on JP11 to restore operation with the MPIDE.

Two red LEDs (LD9 and LD10) will blink when data is being sent or received between the Digilent Pro MX7 and the PC over the serial connection.

The header connector J1 provides access to the other serial handshaking signals provided by the FT232R. Connector J1 is not loaded at the factory but can be installed by the user to access these signals.

1.3 Additional Reference Documentation

Additional information about the Digilent Pro MX7 board and the use and operation of the PIC32MX795F512L microcontroller can be obtained from the following sources.

The Digilent Pro MX7 Schematic, various support libraries, and example reference designs are available on the board product page on the Digilent web site: www.digilentinc.com

The PIC32MX5XX/6XX/7XX Family Data Sheet and the PIC32MX Family Reference Manual are available from the Microchip web site: www.microchip.com

Reference material for the MPIDE system is included in the MPIDE software download and on-line in the chipKIT wiki. Help with questions and problems using the board with the MPIDE software can also be obtained in the chipKIT forums:

www.github.com/chipKIT32 (software download)

www.chipKIT.org/wiki

www.chipKIT.org/forum

2 Board Power Supply

Switch SW1 in the lower left corner of the board is the power switch. Place this switch in the ON position to turn on board power and in the OFF position to turn off board power.

The Digilent Pro MX7 may be USB powered via either the USB debug port, the USB UART port, or the USB device port. Alternatively, the board may be powered via dedicated "external" power supply connectors.

Jumper block J3 selects the power source used to provide power to the board. This jumper block provides the following four positions:

- USB – power is supplied by USB device connector J19. This is used when the Digilent Pro MX7 is being used to implement a USB bus powered device.
- EXT – Power is supplied by one of the external power connectors.
- DBG – Power is supplied by DEBUG USB connector J15.
- UART – Power is supplied by UART USB connector J2.

Place the shorting block in the appropriate position on J3 for the desired power source for the board.

The Digilent Pro MX7 is rated for external power from 3.6 to 5.5 volts DC. Using a voltage outside this range will damage the board and connected devices. For most purposes when using external power, a regulated 5V supply should be used. If the board is operated from an external supply with a voltage less than 5V, some features won't work correctly.

The USB specification requires that USB devices not draw more than 100mA of current until they have enumerated on the USB bus and informed the host that they want to consume more current. To meet this specification, the debugger circuit turns on main board power by driving the PWR_ON signal high after successfully enumerating on the USB bus. The bus labeled on the schematic as VCC5V0 is powered when this occurs. The VCC5V0 bus powers the input to the main board voltage regulator, the input voltage to the USB bus voltage load switch used when using the board as a USB host, the power supply voltage for the CAN transceivers, and the 5V0 side of the power select jumpers for the Pmod ports. The voltage on the VCC5V0 bus will be 5V when the board is being operated from USB power or an external regulated 5V supply. If a different external supply voltage is used, that voltage will appear on the VCC5V0 bus.

The power supply selected by the shorting block on J3 will appear on the input power supply bus, labeled VIN in the schematic. This voltage is regulated to 3.3V to power the licensed debugger circuit by IC11, a Microchip MCP1801 Low Dropout voltage regulator. This regulator is turned on and the debugger circuit is powered whenever the power switch is in the on position. The VIN power bus also supplies power to IC9, a PFET load switch used to turn main board power on or off.

When the power switch is turned on, transistor Q7A attempts to drive the ON/OFF pin of IC9 high to enable the main power supply.

If the licensed debugger is connected to an active USB port, it initially disables the main power supply by holding the PWR_ON signal low. This causes Q8B to hold the ON/OFF pin of IC9 low, forcing the main supply off. The licensed debugger will enumerate with the host computer and once it has successfully enumerated, will turn on the main board power supply by driving the PWR_ON signal high.

If the licensed debugger is not connected to an active USB port, the signal labeled DBG5V0 will not be powered. Transistor Q8B will be unable to hold the ON/OFF pin low and the main power supply will be turned on immediately when the power switch is turned on. When load switch IC9 is turned on, it powers the board unregulated power bus VCC5V0, which provides the input power to the main regulator.

The main board power supply is a switch mode voltage regulator implemented using a Microchip MCP16301 switch mode step-down regulator, IC10. This regulator provides 3.3V at up to 600 mA with approximately 96% efficiency. When the main power supply is enabled, it powers the regulated power bus VCC3V3.

When powering the board from an external power supply, there are two connectors that can be used: J17 and J18.

The barrel connector, J17, is used to power the board from a "wall wart" style power supply. This type of power supply is available from many sources. Digilent has a power supply available, the 5V Switching Power Supply, which can be used with connector J17. Connector J17 is a 2.5mm x 5.5mm coaxial connector wired with the center terminal as the positive voltage.

Connector J18 is a screw terminal connector for an alternative power supply connection for use with battery packs, bench supplies, or other power sources where use of a hard wired power supply is desirable.

Connectors J17 and J18 are wired in parallel and connect to the EXT position on the Power Select jumper block J3. A shorting block should be placed on the "EXT" position of J3 when using this option for board power. Only one of the external power connectors should be used at a time. If multiple power supplies are connected simultaneously, damage to the board or the power supplies may occur.

When the Digilent Pro MX7 is operating as a USB host, an external power supply connected to either J17 or J18 must be used to power the board. In addition to powering the logic on the Digilent Pro MX7 board, this supply provides the USB bus voltage supplied to any connected USB device and must be a regulated 5V with at least 500mA current capability to meet the USB specifications.

The CAN bus operates at 5V, and therefore the transceivers for the two CAN interfaces require 5V to operate correctly and within the CAN specification. When using the CAN network interfaces, the board should be operated from a 5V supply if using an external power supply.

The PIC32 microcontroller and on-board I/O devices operate at a supply voltage of 3.3V provided by the VCC3V3 bus. The main voltage regulator is capable of providing a maximum of 600mA of current. The PIC32 microcontroller will use approximately 85mA when running at 80MHz. The SMSC LAN8720 Ethernet PHY consumes approximately 45mA when operating at 100Mbps. The Microchip MCP2551 CAN transceivers can draw up to 75mA each when operating the CAN busses. The other circuitry on the board will draw 10-20 mA. The remaining current is available to provide power to attached Pmods and I²C devices.

The Digilent Pro MX7 can provide power to any peripheral modules attached to the Pmod ports, JA-JF, and to I²C devices powered from the I²C daisy chain connectors, J7 and J8. Each Pmod port provides power pins that can be powered from either the switched main power bus, VCC5V0, or regulated voltage, VCC3V3, by setting the voltage jumper block to the desired position. The I²C connectors only provide the regulated voltage, VCC3V3.

2.1 RESET

A reset button is at the upper right corner of the board. Pressing this button will reset the PIC32 microcontroller.

3 Pmod Ports

The Digilent Pro MX7 has six connectors for connecting Digilent Pmods. The Pmod ports labeled JA–JF, are 2x6 pin, right-angle, female pin header connectors. Each connector has an associated power select jumper block labeled JPA–JPF.

Digilent Pmods are a line of small peripheral modules that provide various kinds of I/O interfaces. The Pmod product line includes such things as button, switch and LED modules, connector modules, LCD displays, high current output drivers, various kinds of RF interfaces, and many others.

There are two styles of Pmod port: six-pin and twelve-pin. Both connectors use standard pin headers with 100mil spaced pins. The six-pin ports have the pins in a 1x6 configuration, while the twelve-pin ports use a 2x6 configuration. All of the Pmod ports on the Digilent Pro MX7 are twelve pin connectors.

Six-pin Pmod ports provide four I/O signals, ground and a switchable power connection. The twelve-pin ports provide eight I/O signals, two power pins, and two ground pins. The twelve-pin ports have the signals arranged so that one twelve-pin port is equivalent to two of the six-pin ports. Pins 1–4 and 7–10 are the signal pins, pins 5 and 11 are the ground pins, and pins 6 & 12 are the power supply pins.

The pin numbering that Digilent uses on the twelve-pin Pmod ports is non-standard. The upper row of pins are numbered 1–6, left to right (when viewed from the top of the board), and the lower row of pins are numbered 7–12, left to right. This is in keeping with the convention that the upper and lower rows of pins can be considered to be two six-pin ports stacked. When viewed from the end of the connector, pin 1 is the upper right pin and pin 7 is immediately below it (closer to the PCB).

Each Pmod port has an associated power select jumper. These are used to select the power supply voltage supplied to the power supply pins on the Pmod port. They are switchable between either the unregulated power supply, VCC5V0, or the 3.3V main board supply, VCC3V3. Place the shorting block in the 3V3 position for regulated 3.3V and in the 5V0 position to use the unregulated supply.

Each signal pin on the Pmod ports are connected to an input/output pin on the PIC32 microcontroller. Each pin has a 200 ohm series resistor and an ESD protection diode. The series resistor provides short circuit protection to prevent damaging the I/O block in the microcontroller if the pin is inadvertently shorted to VDD or GND, or two outputs are shorted together. The ESD protection diode protects the I/O block from damage due to electro-static discharge.

The 200 ohm resistor in series with each I/O pin limits the amount of current that can be sourced from the microcontroller pins. There will be a 200mV voltage drop per mA of current sourced by the pin. This will not be a problem when driving typical, high impedance, logic inputs, but can be problematic when trying to drive low impedance inputs. In some cases it may be necessary to use external buffers when trying to drive low impedance inputs.

Although ESD protection is provided between the connector pins and the microcontroller pins, ESD safe handling procedures should be followed when handling the circuit board. The pins on the microcontroller and other circuits on the board are exposed and can be damaged through ESD when handling the board.

Digilent Pmods can either be plugged directly into the ports on the Digilent Pro MX7 or attached via cables. Digilent has a variety of Pmod interconnect cables available.

See the Pinout Tables in Appendix C for more information about connecting peripheral modules and other devices to the Digilent Pro MX7. These tables describe the mapping between pins on the PIC32MX795 microcontroller and the pins on the various ports.

The PIC32 microcontroller can source or sink a maximum of 18mA on all digital I/O pins. However, to keep the output voltage within the specified input/output voltage range (V_{OL} 0.4V, V_{OH} 2.4V) the pin current must be restricted to +/-12mA. The maximum current that can be sourced or sunk across all I/O pins simultaneously is +/-200mA. The maximum voltage that can be applied to any digital I/O pin is 5.5V. The maximum voltage that can be applied to any analog input capable pin is 3.6V. For more detailed specifications, refer to the PIC32MX5XX/6XX/7XX Family Data Sheet.

4 Digital Inputs and Outputs

The Digilent Pro MX7 board provides access to 48 of the I/O pins from the PIC32MX795 microcontroller via the Pmod ports. Four additional I/O pins can be accessed via the I²C connectors, J7 and J8. Any of the pins on the Pmod or I²C ports can be individually accessed for digital input or output. Note that when the I²C signals on J7 or J8 are being used for I²C communications, they are not available for general purpose I/O.

On PIC32 microcontrollers, the input/output pins are grouped into I/O Ports and are accessed via peripheral registers in the microcontroller. There are seven I/O Ports numbered A–G and each of the ports are 16 bits wide. Depending on the particular PIC32 microcontroller, some of the I/O Ports are not present, and not all 16 bits are present in all I/O Ports.

Each I/O Port has four associated registers: TRIS, LAT, PORT, and ODC. The registers for I/O Port A are named TRISA, LATA, PORTA, and ODCA. The registers for the other I/O Ports are named similarly.

The TRIS register is used to set the pin direction. Setting a TRIS bit to 0 makes the pin an output. Setting the TRIS bit to 1 makes the pin an input.

The LAT register is used to write to the I/O Port. Writing to the LAT register sets any pins configured as outputs. Reading from the LAT register returns the last value written.

The PORT register is used to read from the I/O Port. Reading from the PORT register returns the current state of all of the pins in the I/O Port. Writing to the PORT register is equivalent to writing to the LAT register.

PIC32 microcontrollers allow any pin set as an output to be configured as either a normal totem-pole output or as an open-drain output. The ODC register is used to control the output type. Setting an ODC bit to 0 makes the pin a normal output and setting it to 1 makes the pin an open drain output.

Refer to the PIC32MX5XX/6XX/7XX Family Data Sheet, and the PIC32 Family Reference Manual, Section 12, I/O Ports, for more detailed information about the operation of the I/O Ports in the microcontroller.

Pmod port JF, pins 8, 9, and 10 are connected to the signals TCK/RA1, TDI/RA4, and TDO/RA5 respectively. These microcontroller pins are shared between general purpose I/O functions and use by the JTAG controller. The JTAG controller is enabled on reset, so these pins are not available for general purpose I/O until the JTAG controller is disabled. The following statement can be used to disable the JTAG controller:

```
DDPCONbits.JTAGEN = 0;
```

The JTAG controller is disabled by the startup initialization code in the MPIDE runtime. It is not necessary to disable the JTAG controller when using the board with MPIDE.

The MPIDE system uses logical pin numbers to identify digital I/O pins on the connectors. These pin numbers start with pin 0 and are numbered up consecutively.

On the Digilent Pro MX7, pin numbers 0-47 are used to access the pins on the Pmod ports and pin numbers 55-58 are used for the signal pins on the I²C connectors, J7 and J8. The pin numbers are assigned so that connector JA pin 1 (JA-01) is digital pin 0, JA pin 2 (JA-02) is digital pin 1, and so on.

Pins 0-7 are on connector JA, pins 8-15 on JB, pins 16-23 on JC, pins 24-31 and so on. Refer to the tables in Appendix B for detailed information about the pin mapping between Pmod port, logical pin number, and PIC32 microcontroller pin number and pin function.

When using the Digilent Pro MX7 with the MPIDE, the functions `pinMode()`, `digitalRead()`, and `digitalWrite()` are used for digital pin I/O.

The `pinMode()` function is used to set the pin direction. Pin direction can be set to: INPUT, OUTPUT, or OPEN. OPEN is used for open-drain and implies output.

The `digitalRead()` and `digitalWrite()` functions are used to read or write the pins. `DigitalRead()` returns the current state of the specified pin, and `digitalWrite()` is used to set the state of an output pin. The pin state can be either HIGH or LOW.

4.1 Push Buttons and LEDs

The Digilent Pro MX7 board provides three push button switches for user input and four LEDs for output. The buttons, BTN1 and BTN2 are connected to I/O Port G, bits 6 and 7 respectively. BTN3 is connected to I/O Port A, bit 0. To read the buttons, pins 6 and 7 of I/O Port G and pin 0 of I/O Port A must be configured as inputs by setting the corresponding bits in the TRISG and TRISA registers. The button state is then obtained by reading the PORTG or PORTA registers. When a button is pressed, the corresponding bit will be high ('1'). The pins used by the buttons are dedicated to this use and do not appear on any connector.

Button BTN3 is connected to the signal TMS/RA0 on the PIC32 microcontroller. This microcontroller pin is shared between general purpose I/O functions and use by the JTAG controller. The JTAG controller is enabled on reset, and so BTN3 is not useable as a button input until the JTAG controller is disabled. The following statement can be used to disable the JTAG controller:

```
DDPCONbits.JTAGEN = 0;
```

The JTAG controller is disabled by the startup initialization code in the MPIDE runtime. It is not necessary to disable the JTAG controller when using the board with MPIDE.

The four LEDs are connected to bits 12-15 of I/O Port G. LED 1 is connected to bit 12; LED 2 is connected to bit 13, and so on. These four pins are dedicated to use with the LEDs and do not appear on any connector pin. To use the LEDs, configure the desired bits as outputs by clearing the corresponding bits in the TRISG register. The state of an LED is set by writing values to the LATG register. Setting a bit to 1 will illuminate the LED and setting the bit to 0 will turn it off.

When using the MPIDE and the Digilent system, the buttons are accessed using `digitalRead()` and the LEDs using `digitalWrite()`. Use the following pins to access them:

- BTN1 – PIN_BTN1, pin 48, RG6
- BTN2 – PIN_BTN2, pin 49, RG7
- BTN3 – PIN_BTN3, pin 50, RA0

- LD1 – PIN_LED1, pin 51, RG12
- LD2 – PIN_LED2, pin 52, RG13
- LD3 – PIN_LED3, pin 53, RG14
- LD4 – PIN_LED4, pin 54, RG15

4.2 5V Signal Compatibility

The PIC32 microcontroller operates at 3.3V and the I/O pins provide 3.3V logic levels; however, it is possible in some circumstances to use the Digilent Pro MX7 to operate with 5V logic devices.

There are two issues to consider when dealing with 5V compatibility for 3.3V logic. The first is protection of 3.3V inputs from damage caused by 5V signals. The second is whether the 3.3V output is high enough to be recognized as a logic high value by a 5V input.

The digital only I/O pins on the PIC32 microcontroller are 5V tolerant. It is safe to apply 5V logic signals directly to these pins without risk of damage to the microcontroller.

The analog capable I/O pins on the PIC32 are not 5V tolerant. The absolute maximum voltage rating for the analog pins is 3.6V. Generally, the analog pins are the pins on I/O port B; however, there are other non-5V tolerant pins on the device.

Refer to the PIC32MX5XX/6XX/7XX Family Data Sheet for more information about which pins on the device are 5V tolerant before applying input signals higher than 3.3V to any pin on the Digilent Pro MX7 board.

If a 5V signal is applied to a non-5V tolerant pin, some external means must be used to limit the applied voltage to 3.6V or less. The Digilent Pro MX7 board provides 200 ohm series resistors between the microcontroller pins and the Pmod port pins. These resistors are primarily intended to provide short circuit protection on the outputs, but will also provide limited protection if a 5V signal is inadvertently applied to a non-5V tolerant pin.

One technique that can be used to limit an input voltage to a safe level is to use a 200 ohm series resistor and Schottky diode connected to the 3.3V supply to clamp the voltage.

The minimum output high voltage of the PIC32 microcontroller is rated at 2.4V when sourcing 12mA of current. When driving a high impedance input (typical of CMOS logic) the output high voltage will be close to 3.3V. Some 5V devices will recognize this voltage as a logic high input, and some won't. Many 5V logic inputs will work reliably with 3.3V inputs.

If the 3.3V logic output is not sufficient for 5V logic input to be reliably seen as a logic high input signal, some external means must be used to raise the output level. In some cases, a pull-up resistor to 5V is sufficient. A pull-up resistor in the range of 2Kohm–10kOhm can be used. This technique should not be used with pins that are not 5V tolerant on the PIC32 microcontroller.

5 CPU Clock Source

The PIC32 microcontroller supports numerous clock source options for the main processor operating clock. The Digilent Pro MX7 board is designed to operate with either a silicon resonator from Discera, IC2, for use with the EC oscillator option, or an external crystal, X1, for use with the XT oscillator option. Standard production boards will have an 8 MHz Discera silicon resonator loaded and the EC oscillator option should be used. If IC2 is not loaded, an 8 MHz crystal will be loaded for X1 (on the bottom of the board) and the XT oscillator option should be used. Oscillator options are selected via the configuration settings specified using the `#pragma config` statement. Use `#pragma config POSCMOD=EC` to select the EC option and `#pragma config POSCMOD=XT` to select the XT option.

Using the internal system clock phase-locked loop (PLL), it is possible to select numerous multiples or divisions of the 8 MHz oscillator to produce CPU operating frequencies up to 80 MHz. The clock circuit PLL provides an input divider, multiplier, and output divider. The external clock frequency (8 MHz) is first divided by the input divider value selected. This is multiplied by the selected multiplier value and then finally divided by the selected output divider. The result is the system clock, SYSCLK, frequency. The SYSCLK frequency is used by the CPU, DMA controller, interrupt controller, and pre-fetch cache.

The operating frequency is selected using the PIC32MX795 configuration variables. These are set using the `#pragma config` statement. Use `#pragma config FPLLIDIV` to set the input divider, `#pragma config FPLLMUL` to set the multiplication factor, and `#pragma config FPLLODIV` to set the output divider. Refer to the PIC32MX5XX/6XX/7XX Family Data Sheet and the PIC32MX Family Reference Manual, Section 6 Oscillators for information on how to choose the correct values, as not all combinations of multiplication and division factors will work.

In addition to configuring the SYSCLK frequency, the peripheral bus clock, PBCLK, frequency is also configurable. The peripheral bus clock is used for most peripheral devices, and in particular is the clock used by the timers and serial controllers (UART, SPI, I²C). The PBCLK frequency is a division of the SYSCLK frequency selected using `#pragma config FPBDIV`. The PBCLK divider can be set to divide by 1, 2, 4, or 8.

The following example will set up the Digilent Pro MX7 for operation with a SYSCLK frequency of 80 MHz and a PBCLK frequency of 10 MHz:

```
#pragma config FNOSC = PRIPLL
#pragma config POSCMOD = EC
#pragma config FPLLIDIV = DIV_2
#pragma config FPLLMUL = MUL_20
#pragma config FPLLODIV = DIV_1
#pragma config FPBDIV = DIV_8
```

Documentation for the PIC32 configuration variables can be found in the PIC32MX Configuration Settings guide. This is found using the "Help.Topics..." command in the MPLAB IDE. Also, refer to Appendix C for an example of setting the configuration variables.

When using the Digilent Pro MX7 with the MPIDE software, the clock source is set by the boot loader and no action is required.

6 Ethernet Interface

The Digilent Pro MX7 provides the ability to interface with 10Mbps or 100Mbps Ethernet networks. The PIC32MX795 microcontroller contains a 10/100 Ethernet Medium Access Controller (MAC). External to the PIC32 microcontroller, the Digilent Pro MX7 board provides an SMSC LAN8720 Ethernet Physical Layer Transceiver (PHY).

Together, the MAC and PHY in combination with an appropriate coupling transformer and RJ45 jack provide a standard 10/100 Ethernet interface.

The RJ45 connector J11 provides the physical connection to an Ethernet network using a standard Ethernet cable.

All devices on an Ethernet network must have a unique address. This address is used to direct packets on the network to a specific device and to identify the device that originated a packet. An Ethernet MAC uses a 48-bit address value, commonly called the "MAC Address". These address values are globally unique to ensure that no two devices on a network can have conflicting addresses. MAC addresses are assigned by the IEEE. Each

PIC32MX795 device is programmed at the factory to have a unique MAC address that will be loaded by default when the device is reset.

Digilent provides another unique MAC address that can be used as well. This address is printed on a sticker attached to the bottom of the board. The Digilent provided MAC address is a twelve digit hexadecimal number of the form: 00183Exxxxx, where xxxxxx represents six hexadecimal digits. This value is used to initialize the Ethernet Controller MAC Station Address registers in the Ethernet controller of the PIC32MX795 microcontroller.

In order to connect to and operate with an Ethernet network, the PIC32 microcontroller must be running network protocol stack firmware. Normally, the TCP/IP (Transmission Control Protocol/Internet Protocol) network protocol is used and "TCP/IP Stack" software must be used. The Microchip Applications Library, available for download from the Microchip web site, provides full protocol stack support compatible with the PIC32MX795 MAC and the LAN8720 PHY. Microchip also provides numerous example programs illustrating the use of their network protocol stack for various applications.

When not using the Microchip network protocol stack, refer to the manufacturer documentation for the PIC32MX795 and LAN8720, plus network protocol documentation, for operation of the Ethernet interface.

Digilent has Network libraries available that can be used to develop both client and server applications when using the board with the MPIDE development environment. These libraries are built on a custom version of the Microchip Applications Library network stack and support various network protocols such as TCP, UDP, DHCP and others to provide complete Ethernet network support. These libraries can be downloaded from the Digilent Pro MX7 product page on the Digilent web site.

The Digilent libraries contain examples illustrating various network applications.

The PIC32MX795 microcontroller provides two alternate sets of pins that can be used to connect the MAC to the external PHY. It also provides two alternate standard MAC/PHY interface signaling conventions. The Digilent Pro MX7 is designed to use the standard (not the alternate) pins, and to use the RMII (not the MII) interface signaling convention. These options are selected using the configuration variables in the PIC32 microcontroller and are specified using the `#pragma config` statement. To enable the Ethernet controller in the correct configuration, the following statements must appear in the main program module:

```
#pragma config FETHIO=ON
#pragma config FMIIEN=OFF
```

The MPIDE boot loader sets these configuration variables, so no action is necessary when using the MPIDE software system.

The LAN8720 PHY has a reset signal, labeled NRST in the schematic, used to reset the PHY. This signal is connected to the TRCLK/RA6 pin on the PIC32 microcontroller. The NRST signal is active low. Configure the microcontroller pin as an output and drive it low to reset the PHY, or drive it high to allow the PHY to come out of reset and begin operation. The NRST signal is pulled low on the board, so that the PHY is held in reset by default. To allow the PHY to operate, this pin must be driven high. This reset operation is not part of the Microchip network protocol stack, and so driving NRST high must be done before initializing the Microchip network stack.

The Digilent network libraries perform this automatically, and so no action is necessary when using the board with the MPIDE software system and the Digilent libraries.

7 USB Interface

The PIC32MX795 microcontroller contains a USB 2.0 Compliant, Full Speed Device and On-The-Go (OTG) controller. This controller provides the following features:

- USB full speed host and device support
- Low speed host support
- USB OTG support
- Endpoint buffering anywhere in system RAM
- Integrated DMA to access system RAM and Flash memory.

The USB controller uses a phased lock loop, PLL, to generate the necessary USB clock frequency from the external primary oscillator input frequency. By default, this PLL is disabled. In order to use the USB controller, it is necessary to enable the USB PLL, and set the input divider to the correct value to generate a valid USB clock. The input to the USB PLL must be 4 MHz. The Digilent Pro MX7 provides an 8 MHz clock to the PIC32 microcontroller, so a USB PLL input divider value of 2 must be used. These parameters are set in the PIC32 microcontroller configuration registers using the `#pragma config` statement. The following statements must be used to configure the PIC32 microcontroller for use of the USB controller:

```
#pragma config UPLLEN = ON
#pragma config UPLLIDIV = DIV_2
```

When using the MPIDE development environment these will have been set by the boot loader, so no action is needed.

When operating as a USB device, the Digilent Pro MX7 can be used as a self-powered device or as a bus powered device. To operate as a self-powered device, an external power supply should be connected to one of the external power connectors (J17 or J18) and a shorting block placed on the "EXT" position of J3. To operate as a bus powered device, the shorting block should be placed in the USB Device position, "USB", on J3.

Note that when operating as a bus powered device, the Digilent Pro MX7 and all devices connected to it are limited to using no more than 500mA of current to remain in compliance with the USB specification.

Connector J19 on the bottom of the board in the lower right corner is the Device/OTG connector. This is a standard USB micro-AB connector. Connect a cable with a micro-A plug (optionally available from Digilent) from this connector to an available USB port on a PC or USB hub for device operation.

When operating as a USB host, the Digilent Pro MX7 must be externally powered. Connect a regulated 5V power supply to one of the external power connectors (J17, or J18) and ensure that the shorting block is in the, "EXT" position of J3. The power supply used must be a regulated 5V supply. The Digilent Pro MX7 board provides power to the attached USB device when operating as a host and the USB specification requires the use of a 5V power supply. NOTE: Providing a voltage greater than 5V can damage the Digilent Pro MX7 board and/or the USB device being used.

Connector J20 on the top of the board in the lower right corner is the USB host connector. This is a standard USB type A receptacle. USB devices may be connected either directly or through a standard USB cable.

Jumper JP10 is used to route power to the host connector being used. Place the shorting block in the "A" position when using the standard USB type A (host) Connector, J20. Place the shorting block in the "MICRO" position for use with the USB micro-AB (OTG) connector, J19.

When operating as a USB host, the PIC32MX795 microcontroller controls application of power to the connected device via the VBUSON control pin. The VBUSON signal is connected to the circuit net labeled P32_VBUSON in the schematic. Bus power is applied to the attached USB device by driving the VBUSON pin high. Power is removed from the device by driving the VBUSON pin low. The VBUSON pin is accessed via bit 3 of the U10TGCON register.

The VBUSON pin drives the enable input of a Texas Instruments TPS2051B Current-Limited Power Distribution Switch to control the application of USB power to the host connector. This switch has over-current detection capability and provides an over-current fault indication by pulling the signal P32_USBOC low. The over-current output indication can be monitored via I/O Port D pin 13 (RD13) on the PIC32MX795 microcontroller. This pin can function as change notification pin 19 (CN19), so that a change notification interrupt can be used to detect the overcurrent condition.

Details about the operation of the TPS2051B can be obtained from the data sheet available at the Texas Instruments web site.

The Microchip Applications Library, MAL, available on the Microchip web site contains USB driver code for implementing either USB host devices or USB function devices. This library contains numerous examples demonstrating both device and host operation of PIC32 microcontrollers. With minor modification or configuration, these reference designs are suitable to use for developing USB firmware for the Digilent Pro MX7 board.

Digilent has USB libraries available that can be used to develop both USB device and USB host applications when using the board with the MPIDE development environment. These libraries are built on a custom version of the Microchip Applications Library and can be downloaded from the Digilent Pro MX7 product page on the Digilent web site.

The Digilent libraries contain examples illustrating various USB host and device applications.

8 CAN Interface

The Controller Area Network (CAN) is a control networking standard originally developed for use in automobile systems, but has since become a standard used in various industrial control and building automation networking applications as well.

The PIC32MX795 microcontroller contains two independent CAN network controllers. These CAN controllers in combination with two Microchip MCP2551 CAN transceivers allow the Digilent Pro MX7 board to operate on up to two independent CAN networks. Refer to the PIC32MX5XX/6XX/7XX Family Data Sheet and the PIC32 Family Reference Manual, Section 34, Controller Area Network (CAN), plus CAN network documentation for information on operation of the CAN controllers and CAN networking in general.

The Microchip C32 peripheral library, plib, provides basic support for all CAN operations using the CAN controllers in the PIC32MX795 microcontroller.

Digilent has a basic CAN library available for use with the MPIDE software environment. This library can be downloaded from the Digilent Pro MX7 product page on the Digilent web site.

The PIC32MX795 microcontroller provides two sets of pins that can be used to connect the CAN controllers to the external transceivers. The Digilent Pro MX7 is designed to use the alternate (not the standard) pins. This selection is made using the configuration variables in the microcontroller, set using a `#pragma config` statement. To select the use of the alternate interface pins, the following statement must appear in the main program module:

```
#pragma config FCANIO=OFF
```

The MPIDE boot loader sets the configuration variables, and so no action is necessary when using the MPIDE software system.

The pins on the PIC32MX795 microcontroller used by signals for the CAN1 controller to connect to its transceiver are shared with two of the signals for the UART2 and SPI4 ports. Jumpers JP1 and JP2 are used to select the use of these two signals. Place JP1 and JP2 in the CAN position for use of the CAN1 network interface. Place JP1 and JP2 in the Pmod position for use of these signals for UART or SPI operation. These signals connect to pins 1 & 4 of Pmod port JF. When JP1 and JP2 are in the CAN position, Pins 1 & 4 of Pmod port JF are not useable. In some cases it may be possible to use UART2 at the same time as CAN1 as the RX and TX pins are not used by the CAN interface (only RTS and CTS are used). When JP1 and JP2 are in the CAN position Pmod pins JF-01 and JF-04 are not connected to the PIC32 microcontroller.

There is no standard connector for use with CAN networks. The Digilent Pro MX7 board provides two 2x6 pin header connectors for access to the CAN signals. Connector J9 provides access to the signals for the CAN1 network controller, and connector J10 provides access to the signals for CAN2. Refer to the Digilent Pro MX7 schematic, Sheet 6, for information on the connectors and signal assignments. Digilent 6-pin or 2x6 to dual 6-pin cables can be used to daisy chain Digilent boards together in a CAN network. A Digilent 6-Pin cable in combination with a Digilent PmodCON1 Screw Terminal Connector module can be used to connect the Digilent Pro MX7 board to other network wiring configurations.

The CAN network standard requires that the network nodes at each end of a network provide 120 ohm termination. The Digilent Pro MX7 provides termination resistors and jumpers to enable/disable them depending on the location of the board in the network. Jumper JP5 is used to enable/disable the termination resistor for the CAN1 network connector, and JP7 is used to enable/disable the termination resistor for CAN2. Install a shorting block on the jumper pins to enable the termination resistor, or remove the shorting block to disable it.

9 UART Interface

The PIC32MX795 microcontroller can provide up to six UARTs. Due to conflicting uses of many of the pins used by the UARTs, the Digilent Pro MX7 is designed to allow use of two of them: UART1 and UART2. The UARTs can provide either a 2-wire or a 4-wire asynchronous serial interface. The 2-wire interface provides receive (RX) and transmit (TX) pins. The 4-wire interface includes request-to-send (RTS), and clear-to-send (CTS), in addition to receive and transmit.

UART1 can be accessed from Pmod port JE and UART2 can be accessed from Pmod port JF using the following pins:

- U1CTS JE-01
- U1TX JE-02
- U1RX JE-03
- U1RTS JE-04

- U2CTS JF-01
- U2TX JF-02
- U2RX JF-03
- U2RTS JF-04

Note that early versions of the Microchip PIC32MX5XX/6XX/7XX Family Data Sheet refer to UART1 as UART1A and UART2 as UART3A.

Detailed information about the operation of the UART peripherals can be found in the PIC32 Family Reference Manual, Section 21, UART.

The USB Serial converter is connected to UART1. The MPIDE uses this to communicate with the boot loader. This can also be used for a serial communications interface between the Digilent Pro MX7 board and other software running on a PC. Resistors are used to decouple the USB serial interface and so UART1 can also be used via Pmod connector JE when not using it to communicate with the USB serial converter.

Note that when using the MPIDE software, devices connected to JE can interfere with the operation of the serial interface and prevent the MPIDE from successfully downloading sketches to the board. If this happens, disconnect the external device from JE until the sketch has been downloaded and then reconnect it.

When using the Digilent Pro MX7 with the MPIDE and the Digilent system, the UARTs are accessed using the HardwareSerial facility built into the system. UART1 Pmod port JE, is accessed using the `Serial` object and UART2 Pmod port JF, is accessed using `Serial1`.

10 Serial Peripheral Interface (SPI)

SPI is a four wire synchronous serial interface and SPI devices can operate as either master devices or as slave devices. The PIC32 microcontroller labels the four SPI signals as Slave Select (SS), Serial Data Out (SDO), Serial Data In (SDI), and Serial Clock (SCK). A master device transmits SS, SDO, SCK, and receives SDI. A slave device receives SS, SDI, SCK, and transmits SDO. The SS signal is used to enable the slave device, and this signal is only significant for slave devices. A master device can use any general purpose I/O pin to generate SS to enable the slave.

An SPI transaction begins with the master device bringing SS low. When the slave sees SS go low it becomes enabled and waits for the master to send data. The master shifts data out on SDO and simultaneously shifts data in on SDI. The slave device receives data from the master on its SDI pin and simultaneously sends data to the master on its SDO pin. Each time the master sends a byte to the slave, it simultaneously receives a byte from the slave.

The PIC32MX795 microcontroller provides four Serial Peripheral Interfaces. The Digilent Pro MX7 supports use of three ports: SPI1, SPI3, and SPI4. These are accessed using Pmod ports JD, JE, and JF.

The following gives the mapping between SPI signals and connector pins:

- SS1 JD-01
- SDO1 JD-02
- SDI1 JD-03
- SCK1 JD-04

- SS3 JE-01
- SDO3 JE-02
- SDI3 JE-03
- SCK3 JE-04

- SS4 JF-01
- SDO4 JF-02
- SDI4 JF-03
- SCK4 JF-04

Note that early versions of the Microchip PIC32MX5XX/6XX/7XX Family Data Sheet refer to SPI3 as SPI1A and SPI4 as SPI3A.

Detailed information about the operation of the SPI peripherals can be found in the PIC32 Family Reference Manual, Section 23, Serial Peripheral Interface.

When using the Digilent Pro MX7 with the MPIDE and the system, the SPI ports are accessed using either the standard SPI library or using the Digilent DSPI library.

The standard SPI library supports access to a single SPI port, SPI4, Pmod connector JF. This is accessed using the SPI object.

The DSPI library supports access to all three SPI ports. The `DSPI0` object class is used to create an object used to access SPI1, Pmod port JD. The `DSPI1` object class is used to access SPI3, Pmod port JE, and the `DSPI2` object class is used to access SPI4, Pmod port JF.

11 I²C Interface

The inter-integrated circuit (I²C) interface provides a medium speed (100K or 400K bps) synchronous serial communications bus. The I²C interface provides master and slave operation using either 7 bit or 10 bit device addressing. Each device is given a unique address, and the protocol provides the ability to address packets to a specific device or to broadcast packets to all devices on the bus. Refer to the Microchip PIC32MX5XX/6XX/7XX Family Data Sheet and the PIC32 Family Reference Manual, Section 24, Inter-Integrated Circuit, for detailed information on configuring and using the I²C interface.

The PIC32MX795 microcontroller provides for up to five independent I²C interfaces. The Digilent Pro MX7 is designed to provide dedicated access to two of these interfaces I2C1 and I2C2 via I²C daisy chain connectors J7 and J8. Connector J7 provides access to I2C1 while connector J8 provides access to I2C2.

In addition to I2C1 and I2C2, two other I²C interfaces, I2C3 and I2C5 can be accessed via pins on Pmod ports. I2C3 can be accessed via Pmod port JE, pins JE-02 (SCL3) and JE-03 (SDA3). I2C5 can be accessed via Pmod port JF, pins JF-02 (SCL5) and JF-03 (SDA5)

The I²C daisy chain connectors, J7 and J8, each provide two positions for connecting to the I²C signals, power and ground. By using two-wire or four-wire MTE cables (available separately from Digilent) a daisy chain of multiple Digilent Pro MX7 boards or other I²C-capable boards can be created.

The I²C bus is an open-collector bus. Devices on the bus actively drive the signals low. The high state on the I²C signals is achieved by pull-up resistors when no device is driving the lines low. One device on the I²C bus must provide the pull-up resistors.

On the Digilent Pro MX7 I2C2, connector J8, has permanently connected 2.2K ohm, pull-up resistors. I2C1, connector J7, provides selectable pull-ups that can be enabled or disabled via jumper blocks JP3 and JP4. The pull-ups are enabled by installing shorting blocks on JP3 and JP4. They are disabled by removing the shorting blocks. Only one device on the bus should have the pull-ups enabled.

If the I²C interfaces on Pmod ports JE or JF are being used, external pull-up resistors must be provided. These resistors can be in the range 1K ohm to 10K ohm, and should be connected to pull the pins to 3.3V.

The pull-ups on I2C1 on the Digilent Pro MX7 board are actually implemented using current mirrors rather than simple resistors. These current mirrors source approximately 1.7mA. The use of current mirrors provides faster rise

times on the I²C signals and provides the ability to drive longer cable runs reliably than would be the case with simple pull-up resistors.

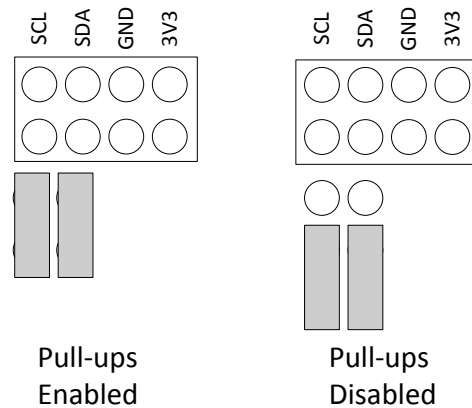

Jumper Settings for I²C Pull-Up Resistor

When using the Digilent Pro MX7 with the MPIDE and the system, the I²C interfaces are accessed using the standard chipKIT Wire library, or the Digilent DTWI library.

The Wire library supports a single I²C interface, I2C2 on J8. This is accessed using the `Wire` object.

The DTWI library supports four I²C interfaces. The `DTWI0` object class is used to create an object for access to I2C1, connector J7, and the `DTWI1` object class is used to access I2C2, connector J8. The `DTWI2` object class is used to access I2C3, Pmod port JE, and the `DTWI3` object class is used to access I2C5, Pmod port JF.

The pinouts of the I²C connectors are as follows:

Connector J7 – I2C1

- J7-1, J7-2 – SCL1
- J7-3, J7-4 – SDA1
- J7-5, J7-6 – GND
- J7-7, J7-8 – VCC3V3

Connector J8 – I2C2

- J8-1, J8-2 – SCL2
- J8-3, J8-4 – SDA2
- J8-5, J8-6 – GND
- J8-7, J8-8 – VCC3V3

Pmod port JE – I2C3

- JE-02 – SCL3
- JE-03 – SDA3

Pmod port JF – I2C5

- JF-02 – SCL5
- JF-03 – SDA5

11.1 On-Board I²C Peripheral Device

The Digilent Pro MX7 provides one on-board I²C peripheral device, a Microchip 24LC256 serial EEPROM. This device is connected to I2C2. The 24LC256 is a 256Kbit (32Kbyte) serial EEPROM device to provide non-volatile memory storage. The device address for the 24LC256 is 1010000 (0x50).

When using the MPIDE software, this device can be accessed using the Wire library `Wire` object, or using the DTWI library via the `DTWI1` object class.

Refer to the Microchip data sheet for detailed information on the operation of this device.

12 Analog Inputs

The PIC32MX795 microcontroller provides a 10-bit analog to digital (A/D) converter that provides up to sixteen analog inputs. The Digilent Pro MX7 board provides access to 10 of these inputs via the Pmod ports. The converted values produced by the A/D converter will be in the range 0–1023.

For detailed information on the operation and use of the A/D converter, refer to the PIC32 Family Reference Manual, Section 17, 10-bit AD Converter.

The analog inputs are accessed using the `analogRead()` function in the MPIDE software. The analog input pin number is specified using the symbols A0–A9. The digital pin numbers for the pins or the numbers 0–9 can also be used, but using the symbols A0–A9 is recommended.

The following gives the Pmod port position, digital pin number, microcontroller I/O port, and bit number for the analog inputs:

- A0 – JA-01, digital pin 0, RB02
- A1 – JA-02, digital pin 1, RB03
- A2 – JA-03, digital pin 2, RB04
- A3 – JA-04, digital pin 3, RB06
- A4 – JA-07, digital pin 4, RB07
- A5 – JA-08, digital pin 5, RB08
- A6 – JA-09, digital pin 6, RB09
- A7 – JA-10, digital pin 7, RB10
- A8 – JC-07, digital pin 20, RB15
- A9 – JC-10, digital pin 23, RB14

12.1 A/D Converter Voltage Reference

The PIC32 microcontroller provides two voltage reference inputs to the analog to digital converter. `Vref-` is used set the lower reference level and `Vref+` is used to set the upper reference level. These references can be connected to internal references or to external references using two of the analog input pins.

When the internal references are being used, `Vref-` is connected to `VSS` and `Vref+` is connected to `VDD`. This means that the voltage input range at the analog input pins is 0V–3.3V. In this case, an input voltage of 0V will convert to ~0, an input voltage of 1.65V will convert to ~511, and an input voltage of 3.3V will convert to ~1023.

Either one, or both, of the references can be connected to external reference pins. When this is done, the references can be set to voltages other than 0V and 3.3V.

If, for example, both references were selected to use external references, with 1V applied to Vref- and 2V applied to Vref+, the input voltage range at the analog input pins would be from 1V to 2V. An applied voltage of 1V would have a converted value of ~0, 1.5V would have a converted value of ~511, and 2V would have a converted value of ~1023.

When both external references are being used, Vref+ must have a higher voltage applied to it than Vref-.

The analog reference input pins appear on Pmod port JE, pins 9 & 10. Vref- is on pin JE-09, and Vref+ is on pin JE-10. These pins are not available to be used for digital I/O when being used as an external reference.

When using the MPIDE software, the use of external analog references is selected using the `analogReference()` function. The following values can be used with `analogReference()`:

- DEFAULT – Vref- = 0V, Vref+ = 3.3V
- INTERNAL – same as default
- EXTERNAL – Vref- = 0V, Vref+ = voltage at A2
- EXTMINUS – Vref- = voltage at A3, Vref+ = 3.3V
- EXTPLUSMINUS – Vref- = voltage at A3, Vref+ = voltage at A2

13 Timers

The PIC32MX795 microcontroller provides five timers that can be used for various timing functions. These timers are each 16 bits wide, although two pairs, TIMER2/TIMER3 and TIMER4/TIMER5 can be combined to produce 32 bit wide timers.

A timer consists of a control register, a counter register, and a period register. The control register is used to configure the timer for various modes of operation. The count register counts cycles of the clock source selected via the control register. This clock source can be the peripheral bus clock or a division of the peripheral bus clock via a prescaler divider. The period register can be used to generate an interrupt and/or reset the count register when a predetermined value is reached.

Each timer has an associated input pin. In some operating modes, this pin can be used as an external clock input to the timer, or as a gate input to turn on/off incrementing of the counter register under control of an external signal.

The following gives the Pmod port position, pin number, microcontroller I/O port, and bit number for the timer input pins.

- T1CK – not available
- T2CK – JC-01, digital pin 16, RC01
- T3CK – not available
- T4CK – not available
- T5CK – JD-03, digital pin 26, RC04

For detailed information on the operation of the PIC32 timers, refer to the PIC32 Family Reference Manual, Section 14, Timers.

When using the MPIDE software, the symbols `PIN_TCK2` and `PIN_TCK5` can be used to access the timer input pins.

Control and operation of the timers is not explicitly provided in the current version of the MPIDE software. This capability will be added in a future version of the software; however, timers are used implicitly by various core functions and libraries.

14 Output Compare

The PIC32MX795 microcontroller provides five output compare units that can be used to control the timing of state changes on certain output pins or to generate pulse width modulated (PWM) outputs.

Each output compare unit works with a particular output pin (OC1-OC5). It can be programmed to control the pin in any of the following ways:

- PWM output
- Generate continuous pulses
- Generate a single pulse
- Toggle the output pin
- Generate falling edge
- Generate rising edge

The output compare units work in conjunction with a timer. Either Timer2 or Timer3 can be used with any of the five output compare units.

Refer to the PIC32 Family Reference Manual, Section 16, Output Compare for detailed information on the use of the output compare units.

When using the MPIDE software, these are accessed using the `analogWrite()` function. The digital pin number, or preferably, the symbols `PIN_OC1` through `PIN_OC5` are used to specify the pin. The MPIDE software currently only supports using the output compare units to generate PWM outputs. It uses Timer2 to control the output compares.

The following gives Pmod port position, pin number, and microcontroller I/O port and bit number for the output compare unit's output pins:

- OC1 – JD-02, digital pin 25, RD00
- OC2 – JD-07, digital pin 28, RD01
- OC3 – JD-08, digital pin 29, RD02
- OC4 – JD-09, digital pin 30, RD03
- OC5 – JC-09, digital pin 22, RD04

15 Input Capture

The PIC32MX795 microcontroller provides five input capture units. The design of the Digilent Pro MX7 board allows the use of three of them.

An input capture unit works in conjunction with a timer and monitors the state of an associated pin. When the pin changes state, the current value of the timer is captured. The input capture units can be used with either Timer2 or Timer3.

The input capture unit can be programmed to be sensitive to either a rising edge, a falling edge, or both edges on the input pin. An interrupt can also be signaled when an input capture is triggered. Each input capture has a four level deep FIFO that can buffer up to four capture events.

For detailed information on the operation and use of the input capture units, refer to the PIC32 Family Reference Manual, Section 15, Input Capture.

The following gives the Pmod port position, pin number, and microcontroller port and bit number for the input capture units input pins:

- IC1 – not available
- IC2 – JD-01, digital pin 24, RD09
- IC3 – JD-04, digital pin 27, RD10
- IC4 – not available
- IC5 – JD-10, digital pin 31, RD12

When using the MPIDE software, the symbols PIN_IC2, PIN_IC3, and PIN_IC5 can be used to access the capture input pins.

Use of the input capture units is not currently supported in the MPIDE software. This will be added in a future version.

16 External Interrupts

The PIC32 microcontroller provides five external interrupt inputs. An external interrupt input can be used to generate an interrupt to the microprocessor CPU when the pin changes state. They can be programmed to interrupt on a rising edge or a falling edge on the pin.

Refer to the PIC32 Family Reference Manual, Section 8, Interrupts for more information on the operation of the external interrupts.

These are accessed using the `attachInterrupt()` and `detachInterrupt()` functions when using the MPIDE software. The interrupt number is specified using the numbers 0-4, or preferably, the symbols EXT_INT0 through EXT_INT4. The symbols PIN_INT0 through PIN_INT4 are also defined to refer to the digital pin numbers used for the external interrupt inputs.

The following gives connector position, pin number, and microcontroller I/O port and bit number. Note that INT0-INT1 are on Pmod ports. INT3 and INT4 are on I2C1 daisy chain connector J7. When using these pins as external interrupt inputs, they are not available to use for I²C. It may also be necessary to disable the pull-ups by pulling the shorting blocks from JP3 or JP4.

- INT0 – JD-02, digital pin 25, RD00
- INT1 – JE-07, digital pin 36, RE08
- INT2 – JF-07, digital pin 44, RE09
- INT3 – J7-1 & J7-2, digital pin 57, RA14
- INT4 – J7-3 & J7-4, digital pin 58, RA15

17 RTCC

The PIC32 microcontroller contains a low frequency oscillator and Real Time Clock/Calendar circuit, RTCC, which can be used to maintain time and date information. The operation of the RTCC requires a 32.768 KHz frequency source. The crystal X2 position, just above and on the right of the PIC32 microcontroller, IC1, is provided for the user to solder in a 32 KHz watch crystal. The Citizen CFS206-32.768KDZF-UB is a crystal part that can be used in this location.

Appendix A: Connector Descriptions and Jumper Settings

Label	Function
JA-JF	<p>Pmod Ports</p> <p>These connectors provide access to the I/O pins on the PIC32MX795 microcontroller. Digilent Pmods can be attached to these ports. These ports can be used for general access to I/O pins on the PIC32MX795 microcontroller.</p>
JPA – JPF	<p>Pmod Port Power Select</p> <p>Any of the Pmod ports can provide either regulated or unregulated power. To use regulated power, place the jumper block over the center pin and the pin marked 3V3. To use unregulated power, place the jumper block over the center pin and the pin marked 5V0.</p>
J1	<p>USB Serial converter auxiliary signals</p> <p>This connector can be used to access the auxiliary RS232 handshaking signals not used on the Digilent MX4 board.</p>
J2	<p>USB Serial converter (UART) connector</p> <p>This USB micro-AB connector is used to connect the FT232R serial converter to a USB port on the user PC.</p>
J3	<p>Power supply source select</p> <p>This jumper is used to select the source of main board power.</p> <p>Place the shorting block in the "USB" position to have the board powered from the USB device connector, J19.</p> <p>Place the shorting block in the "EXT" position to have the board powered from one of the external power connectors, J17 or J18.</p> <p>Place the shorting block in the "DBG" position to have the board powered from the debug USB connector, J15.</p> <p>Place the shorting block in the "UART" position to have the board powered from the USB serial converter connector, J2</p>
J7	<p>I2C1 daisy chain connector</p> <p>This connector provides access to the I2C signals, power, and ground for I2C1.</p>
J8	<p>I2C2 daisy chain connector</p> <p>This connector provides access to the I2C signals, power, and ground for I2C2.</p>
J9	<p>CAN #1 Connector</p> <p>This connector is used to access the signals for CAN #1.</p>
J10	<p>CAN #2 Connector</p> <p>This connector is used to access the signals for CAN #2.</p>
J11	<p>Ethernet Connector</p> <p>This connector provides access to the 10/100 Ethernet port.</p>
J12-J14	<p>Do Not Use.</p>
J15	<p>Debug USB Connector</p>

	This connector is used to connect the on-board programming and debug circuit to the PC for use with the MPLAB IDE.
J17	External Power Connector This is a 2.5mm x 5.5mm, center positive, coax power connector used to provide external power to the board. The optional Digilent 5V Switching Power Supply is connected here.
J18	External Power Connector This is a screw terminal connector used to provide external power to the board. Be sure to observe proper polarity (marked near the connector) when providing power via this connector, or damage to the board and/or connected devices may result.
J19	USB Device / OTG Connector This is a USB micro-AB connector. It is used when using the PIC32MX795 microcontroller to implement a USB device or OTG Host/Device.
J20	USB Host Connector This is a standard sized USB type A connector. This connector is used to connect USB devices to the board when using the PIC32MX795 microcontroller to implement an embedded USB host.
JP1 & JP2	CAN or Pmod Select These jumpers select microcontroller signals RF12 and RF13 for use with CAN #1 or Pmod port JF. Place these jumpers in the CAN position to use CAN #1. Place the jumpers in the PMOD position to use then with Pmod port JF.
JP3 & JP4	Pull-up enable for I2C1 These two jumpers are used to enable/disable the pull-up resistors on I2C1. Insert shorting blocks on these two jumpers to enable the pull-up resistors. Remove the shorting blocks to disable the pull-up resistors. Only a single device on the I ² C bus should have the pull-up resistors enabled.
JP5	CAN #1 Termination This jumper is used to enable/disable the 120 ohm termination resistor for CAN #1. Insert the shorting block to enable the termination resistor, remove it to disable the termination resistor.
JP6	CAN #1 5V0 Enable This jumper is used to enable/disable providing 5V to the CAN #1 connector. Insert the shorting block to connect the board 5V0 supply to pins 9 & 10 of CAN #1 connector. Remove the shorting block to disconnect the 5V0 supply.
JP7	CAN #2 Termination This jumper is used to enable/disable the 120 ohm termination resistor for CAN #2. Insert the shorting block to enable the termination resistor, remove it to disable the termination resistor.
JP8	CAN #1 5V0 Enable This jumper is used to enable/disable providing 5V to the CAN #1 connector. Insert the shorting block to connect the board 5V0 supply to pins 9 & 10 of CAN #1 connector. Remove the shorting block to disconnect the 5V0 supply.
JP9	Do Not Use.
JP10	USB host power select This jumper is used to select which host connector is powered when host power is enabled. Place the shorting block in the "MICRO" position to supply power to the USB micro-AB OTG Connector, J19. Place the shorting block in the "A" position to supply power to the USB type A Host Connector, J20.

JP11	USB Serial converter reset disconnect This is used to connect/disconnect the USB serial converter reset circuit from the PIC32 MCLR pin. The shorting block must be in place on this jumper when using the MPIDE development tools. Remove the shorting block if the USB serial converter is interfering with proper operation of the licensed debugger circuit.
JP17	Do Not Use.

Appendix B: Example of Configuration Values

The following example illustrates setting the configuration values in the PIC32 microcontroller on the Digilent Pro MX7. The microcontroller configuration should be done in a single source file in the project, and is typically done in the 'main' project source file. This example sets all configuration values to valid values for the Digilent Pro MX7 board. It sets the system clock for processor operation at 80 MHz, and the peripheral bus at 10 MHz.

```

/* ----- */
/*          PIC32 Configuration Settings          */
/* ----- */

/* Oscillator Settings
*/
#pragma config FNOSC      = PRIPLL      // Oscillator selection
#pragma config POSCMOD    = EC          // Primary oscillator mode
#pragma config FPLLIDIV   = DIV_2      // PLL input divider
#pragma config FPLLMUL    = MUL_20     // PLL multiplier
#pragma config FPLLODIV   = DIV_1      // PLL output divider
#pragma config FPBDIV     = DIV_8      // Peripheral bus clock divider
#pragma config FSOSCEN    = OFF        // Secondary oscillator enable

/* Clock control settings
*/
#pragma config IESO       = OFF        // Internal/external clock switchover
#pragma config FCKSM      = CSDCMD     // Clock switching (CSx)/Clock monitor
(CMx)
#pragma config OSCIOFNC   = OFF        // Clock output on OSCO pin enable

/* USB Settings
*/
#pragma config UPLEN      = ON         // USB PLL enable
#pragma config UPLLIDIV   = DIV_2     // USB PLL input divider
#pragma config FVBUSONIO  = OFF       // VBUS pin control
#pragma config FUSBIDIO   = OFF       // USBID pin control

/* Other Peripheral Device settings
*/
#pragma config FWDTEN     = OFF        // Watchdog timer enable
#pragma config WDTPS      = PS1024    // Watchdog timer post-scaler
#pragma config FSRSEL     = PRIORITY_7 // SRS interrupt priority
#pragma config FCANIO     = OFF        // Standard/alternate CAN pin select
#pragma config FETHIO     = ON         // Standard/alternate ETH pin select
#pragma config FMIIEN     = OFF        // MII/RMII select (OFF=RMII)

/* Code Protection settings
*/
#pragma config CP         = OFF        // Code protection
#pragma config BWP        = OFF        // Boot flash write protect
#pragma config PWP        = OFF        // Program flash write protect

/* Debug settings
*/
#pragma config ICESEL     = ICS_PGx1   // ICE pin selection

```

Appendix C: Connector Pinout Tables

Arranged by Microcontroller Pin Number

PIC32 Pin #	Connector Pin	Pin #	MCU Port Bit	PIC32 Signal Name	Notes
1	LD4	54	RG15	AERXERR/RG15	LED4
3	JB-08	13	RE05	PMD5/RE5	
4	JB-09	14	RE06	PMD6/RE6	
5	JB-10	15	RE07	PMD7/RE7	
6	JC-01	16	RC01	T2CK/RC1	
7	N/A	N/A	RC02	T3CK/AC2TX/RC2	CAN2
8	N/A	N/A	RC03	T4CK/AC2RX/RC3	CAN2
9	JD-03	26	RC04	T5CK/SDI1/RC4	
10	BTN1	47	RG06	.../SCK2A/U2BTX/U2ARTS/PMA5/CN8/RG6	BTN1
11	BTN2	49	RG07	.../SDA2A/SDI2A/U2ARX/PMA4/CN9/RG7	BTN2
12	N/A	N/A	RG08	.../SCL2A/SDO2A/U2ATX/PMA3/CN10/RG8	Ethernet PHY
14	N/A	N/A	RG09	.../SS2A/U2BRX/U2ACTS/PMA2/CN11/RG9	Ethernet PHY
17	BTN3	50	RA00	TMS/RA0	BTN3
18	JE-07	36	RE08	AERXD0/INT1/RE8	
19	JF-07	44	RE09	AERXD1/INT2/RE9	
20	N/A	59	RB05	AN5/C1IN+/VBUSON/CN7/RB5	USB VBUSON
21	JA-03	2	RB04	AN4/C1IN-/CN6/RB4	
22	JA-02	1	RB03	AN3/C2IN+/CN5/RB3	
23	JA-01	0	RB02	AN2/C2IN-/CN4/RB2	
24	N/A	N/A	RB01	PGEC1/AN1/CN3/RB1	debug PGD
25	N/A	N/A	RB00	PGED1/AN0/CN2/RB0	debug PGC
26	JA-04	3	RB06	PGEC2/AN6/OCFA/RB6	
27	JA-07	4	RB07	PGED2/AN7/RB7	
28	JE-09	38	RA09	Vref-/CVref-/AERXD2/PMA7/RA9	
29	JE-10	39	RA10	Vref+/CVref+/AERXD3/PMA6/RA10	
32	JA-08	5	RB08	AN8/C1OUT/RB8	
33	JA-09	6	RB09	AN9/C2OUT/RB9	
34	JA-10	7	RB10	CVrefout/PMA13/AN10/RB10	
35	N/A	N/A	RB11	AN11/ERXERR/AETXERR/PMA12/RB11	Ethernet PHY
38	JF-08	45	RA01	TCK/RA1	
39	JF-04	43	RF13	AC1TX/SCK3A/U3BTX/U3ARTS/RF13	also CAN1 (JP-2)
40	JF-01	40	RF12	AC1RX/SS3A/U3BRX/U3ACTS/RF12	also CAN1 (JP-1)
41	N/A	N/A	RB12	AN12/ERXD0/AECRS/PMA11/RB12	Ethernet PHY
42	N/A	N/A	RB13	AN13/ERXD1/AECOL/PMA10/RB13	Ethernet PHY
43	JC-10	23	RB14	AN14/ERXD2/AETXD3/PMALH/PMA1/RB14	

44	JC-07	20	RB15	AN15/.../OCFB/PMALL/PMA0/CN12/RB15	
47	JE-01	32	RD14	AETXD0/SS1A/U1BRX/U1ACTS/CN20/RD14	
48	JE-04	35	RD15	AETXD1/SCK1A/U1BTX/U1ARTS/CN21/RD15	
49	JF-03	42	RF04	SDA3A/SDI3A/U3ARX/PMA9/CN17/RF4	
50	JF-02	41	RF05	SCL3A/SDO3A/U3ATX/PMA8/CN18/RF5	
51	N/A	N/A	RF03	USBID/RF3	USBID (USB-4)
52	JE-03	34	RF02	SDA1A/SDI1A/U1ARX/RF2	
53	JE-02	33	RF08	SCL1A/SDO1A/U1ATX/RF8	
56	N/A	N/A	RG03	D-/RG3	D- (USB-2)
57	N/A	N/A	RG02	D+/RG2	D+ (USB-3)
58	J7-1,J7-2	55	RA02	SCL2/RA2	I2C2
59	J7-3,J7-4	56	RA03	SDA2/RA3	I2C2
60	JF-09	46	RA04	TDI/RA4	
61	JF-10	48	RA05	TDO/RA5	
63	N/A	N/A	RC12	OSC1/CLKI/RC12	Primary Oscillator
64	N/A	N/A	RC15	OSC2/CLKO/RC15	Primary Oscillator
66	J8-1,J8-2	57	RA14	AETXCLK/SCL1/INT3/RA14	I2C1
67	J8-3,J8-4	58	RA15	AETXEN/SDA1/INT4/RA15	I2C1
68	N/A	N/A	RD08	RTCC/EMDIO/AEMDIO/IC1/RD8	Ethernet PHY
69	JD-01	24	RD09	SS1/IC2/RD9	
70	JD-04	27	RD10	SCK1/IC3/PMCS2/PMA15/RD10	
71	N/A	N/A	RD11	EMDC/AEMDC/IC4/PMCS1/PMA14/RD11	Ethernet PHY
72	JD-02	25	RD00	SDO1/OC1/INT0/RD0	
73	N/A	N/A	RC13	SOSCI/CN1/RC13	Secondary Oscillator
74	N/A	N/A	RC14	SOSCO/T1CK/CN0/RC14	Secondary Oscillator
76	JD-07	28	RD01	OC2/RD1	
77	JD-08	29	RD02	OC3/RD2	
78	JD-09	30	RD03	OC4/RD3	
79	JD-10	31	RD12	ETXD2/IC5/PMD12/RD12	
80	N/A	60	RD13	ETXD3/PMD13/CN19/RD13	USB Overcurrent
81	JC-09	22	RD04	OC5/PMWR/CN13/RD4	
82	JC-08	21	RD05	PMRD/CN14/RD5	
83	N/A	N/A	RD06	ETXEN/PMD14/CN15/RD6	Ethernet PHY
84	JC-04	19	RD07	ETXCLK/PMD15/CN16/RD7	
87	N/A	N/A	RF00	C1RX/ETXD1/PMD11/RF0	Ethernet PHY
88	N/A	N/A	RF01	C1TX/ETXD0/PMD10/RF1	Ethernet PHY
89	JC-03	18	RG01	C2TX/ETXERR/PMD9/RG1	
90	JC-02	17	RG00	C2RX/PMD8/RG0	
91	N/A	N/A	RA06	TRCLK/RA6	Ethernet PHY Reset
92	JE-08	37	RA07	TRD3/RA7	

93	JB-01	8	RE00	PMD0/RE0	
94	JB-02	9	RE01	PMD1/RE1	
95	LD3	53	RG14	TRD2/RG14	LED3
96	LD1	51	RG12	TRD1/RG12	LED1
97	LD2	52	RG13	TRD0/RG13	LED2
98	JB-03	10	RE02	PMD2/RE2	
99	JB-04	11	RE03	PMD3/RE3	
100	JB-07	12	RE04	PMD4/RE4	

Arranged by Connector Pin Number and Digital Pin Number

PIC32 Pin #	Connector Pin	Pin #	MCU Port Bit	PIC32 Signal Name	Notes
23	JA-01	0	RB02	AN2/C2IN-/CN4/RB2	
22	JA-02	1	RB03	AN3/C2IN+/CN5/RB3	
21	JA-03	2	RB04	AN4/C1IN-/CN6/RB4	
26	JA-04	3	RB06	PGEC2/AN6/OCFA/RB6	
27	JA-07	4	RB07	PGED2/AN7/RB7	
32	JA-08	5	RB08	AN8/C1OUT/RB8	
33	JA-09	6	RB09	AN9/C2OUT/RB9	
34	JA-10	7	RB10	CVrefout/PMA13/AN10/RB10	
93	JB-01	8	RE00	PMD0/RE0	
94	JB-02	9	RE01	PMD1/RE1	
98	JB-03	10	RE02	PMD2/RE2	
99	JB-04	11	RE03	PMD3/RE3	
100	JB-07	12	RE04	PMD4/RE4	
3	JB-08	13	RE05	PMD5/RE5	
4	JB-09	14	RE06	PMD6/RE6	
5	JB-10	15	RE07	PMD7/RE7	
6	JC-01	16	RC01	T2CK/RC1	
90	JC-02	17	RG00	C2RX/PMD8/RG0	
89	JC-03	18	RG01	C2TX/ETXERR/PMD9/RG1	
84	JC-04	19	RD07	ETXCLK/PMD15/CN16/RD7	
44	JC-07	20	RB15	AN15/.../OCFB/PMALL/PMA0/CN12/RB15	
82	JC-08	21	RD05	PMRD/CN14/RD5	
81	JC-09	22	RD04	OC5/PMWR/CN13/RD4	
43	JC-10	23	RB14	AN14/ERXD2/AETXD3/PMALH/PMA1/RB14	
69	JD-01	24	RD09	SS1/IC2/RD9	
72	JD-02	25	RD00	SDO1/OC1/INT0/RD0	
9	JD-03	26	RC04	T5CK/SDI1/RC4	
70	JD-04	27	RD10	SCK1/IC3/PMCS2/PMA15/RD10	
76	JD-07	28	RD01	OC2/RD1	
77	JD-08	29	RD02	OC3/RD2	
78	JD-09	30	RD03	OC4/RD3	
79	JD-10	31	RD12	ETXD2/IC5/PMD12/RD12	
47	JE-01	32	RD14	AETXD0/SS1A/U1BRX/U1ACTS/CN20/RD14	

53	JE-02	33	RF08	SCL1A/SDO1A/U1ATX/RF8	
52	JE-03	34	RF02	SDA1A/SDI1A/U1ARX/RF2	
48	JE-04	35	RD15	AETXD1/SCK1A/U1BTX/U1ARTS/CN21/RD15	
18	JE-07	36	RE08	AERXD0/INT1/RE8	
92	JE-08	37	RA07	TRD3/RA7	
28	JE-09	38	RA09	Vref-/CVref-/AERXD2/PMA7/RA9	
29	JE-10	39	RA10	Vref+/CVref+/AERXD3/PMA6/RA10	
40	JF-01	40	RF12	AC1RX/SS3A/U3BRX/U3ACTS/RF12	also CAN1 (JP-1)
50	JF-02	41	RF05	SCL3A/SDO3A/U3ATX/PMA8/CN18/RF5	
49	JF-03	42	RF04	SDA3A/SDI3A/U3ARX/PMA9/CN17/RF4	
39	JF-04	43	RF13	AC1TX/SCK3A/U3BTX/U3ARTS/RF13	also CAN1 (JP-2)
19	JF-07	44	RE09	AERXD1/INT2/RE9	
38	JF-08	45	RA01	TCK/RA1	
60	JF-09	46	RA04	TDI/RA4	
10	BTN1	47	RG06	.../SCK2A/U2BTX/U2ARTS/PMA5/CN8/RG6	BTN1
61	JF-10	48	RA05	TDO/RA5	
11	BTN2	49	RG07	.../SDA2A/SDI2A/U2ARX/PMA4/CN9/RG7	BTN2
17	BTN3	50	RA00	TMS/RA0	BTN3
96	LD1	51	RG12	TRD1/RG12	LED1
97	LD2	52	RG13	TRD0/RG13	LED2
95	LD3	53	RG14	TRD2/RG14	LED3
1	LD4	54	RG15	AERXERR/RG15	LED4
58	J7-1,J7-2	55	RA02	SCL2/RA2	I2C2
59	J7-3,J7-4	56	RA03	SDA2/RA3	I2C2
66	J8-1,J8-2	57	RA14	AETXCLK/SCL1/INT3/RA14	I2C1
67	J8-3, J8-4	58	RA15	AETXEN/SDA1/INT4/RA15	I2C1
20	N/A	59	RB05	AN5/C1IN+/VBUSON/CN7/RB5	USB VBUSON
80	N/A	60	RD13	ETXD3/PMD13/CN19/RD13	USB Overcurrent detect
7	N/A	N/A	RC02	T3CK/AC2TX/RC2	CAN2
8	N/A	N/A	RC03	T4CK/AC2RX/RC3	CAN2
12	N/A	N/A	RG08	.../SCL2A/SDO2A/U2ATX/PMA3/CN10/RG8	Ethernet PHY
14	N/A	N/A	RG09	.../SS2A/U2BRX/U2ACTS/PMA2/CN11/RG9	Ethernet PHY
24	N/A	N/A	RB01	PGEC1/AN1/CN3/RB1	debug PGD
25	N/A	N/A	RB00	PGED1/AN0/CN2/RB0	debug PGC
35	N/A	N/A	RB11	AN11/ERXERR/AETXERR/PMA12/RB11	Ethernet PHY
41	N/A	N/A	RB12	AN12/ERXD0/AECRS/PMA11/RB12	Ethernet PHY

42	N/A	N/A	RB13	AN13/ERXD1/AECOL/PMA10/RB13	Ethernet PHY
51	N/A	N/A	RF03	USBID/RF3	USBID (USB-4)
56	N/A	N/A	RG03	D-/RG3	D- (USB-2)
57	N/A	N/A	RG02	D+/RG2	D+ (USB-3)
63	N/A	N/A	RC12	OSC1/CLKI/RC12	Primary Oscillator
64	N/A	N/A	RC15	OSC2/CLKO/RC15	Primary Oscillator
68	N/A	N/A	RD08	RTCC/EMDIO/AEMDIO/IC1/RD8	Ethernet PHY
71	N/A	N/A	RD11	EMDC/AEMDC/IC4/PMCS1/PMA14/RD11	Ethernet PHY
73	N/A	N/A	RC13	SOSCI/CN1/RC13	Secondary Oscillator
74	N/A	N/A	RC14	SOSCO/T1CK/CN0/RC14	Secondary Oscillator
83	N/A	N/A	RD06	ETXEN/PMD14/CN15/RD6	Ethernet PHY
87	N/A	N/A	RF00	C1RX/ETXD1/PMD11/RF0	Ethernet PHY
88	N/A	N/A	RF01	C1TX/ETXD0/PMD10/RF1	Ethernet PHY
91	N/A	N/A	RA06	TRCLK/RA6	Ethernet PHY Reset

Arranged by MCU Port and Bit Number

PIC32 Pin #	Connector Pin #	Pin #	MCU Port Bit	PIC32 Signal Name	Notes
17	BTN3	50	RA00	TMS/RA0	BTN3
38	JF-08	45	RA01	TCK/RA1	
58	J7-1, J7-2	55	RA02	SCL2/RA2	I2C2
59	J7-3, J7-4	56	RA03	SDA2/RA3	I2C2
60	JF-09	46	RA04	TDI/RA4	
61	JF-10	48	RA05	TDO/RA5	
91	N/A	47	RA06	TRCLK/RA6	Ethernet PHY Reset
92	JE-08	37	RA07	TRD3/RA7	
28	JE-09	38	RA09	Vref-/CVref-/AERXD2/PMA7/RA9	
29	JE-10	39	RA10	Vref+/CVref+/AERXD3/PMA6/RA10	
66	J8-1, J8-2	57	RA14	AETXCLK/SCL1/INT3/RA14	I2C1
67	J8-3, J8-4	58	RA15	AETXEN/SDA1/INT4/RA15	I2C1
25	N/A	N/A	RB00	PGED1/AN0/CN2/RB0	debug PGC
24	N/A	N/A	RB01	PGEC1/AN1/CN3/RB1	debug PGD
23	JA-01	0	RB02	AN2/C2IN-/CN4/RB2	
22	JA-02	1	RB03	AN3/C2IN+/CN5/RB3	
21	JA-03	2	RB04	AN4/C1IN-/CN6/RB4	
20	N/A	59	RB05	AN5/C1IN+/VBUSON/CN7/RB5	USB VBUSON
26	JA-04	3	RB06	PGEC2/AN6/OCFA/RB6	
27	JA-07	4	RB07	PGED2/AN7/RB7	
32	JA-08	5	RB08	AN8/C1OUT/RB8	
33	JA-09	6	RB09	AN9/C2OUT/RB9	
34	JA-10	7	RB10	CVrefout/PMA13/AN10/RB10	
35	N/A	N/A	RB11	AN11/ERXERR/AETXERR/PMA12/RB11	Ethernet PHY
41	N/A	N/A	RB12	AN12/ERXD0/AECRS/PMA11/RB12	Ethernet PHY
42	N/A	N/A	RB13	AN13/ERXD1/AECOL/PMA10/RB13	Ethernet PHY
43	JC-10	23	RB14	AN14/ERXD2/AETXD3/PMALH/PMA1/RB14	
44	JC-07	20	RB15	AN15/.../OCFB/PMALL/PMA0/CN12/RB15	
6	JC-01	16	RC01	T2CK/RC1	
7	N/A	N/A	RC02	T3CK/AC2TX/RC2	CAN2

8	N/A	N/A	RC03	T4CK/AC2RX/RC3	CAN2
9	JD-03	26	RC04	T5CK/SDI1/RC4	
63	N/A	N/A	RC12	OSC1/CLKI/RC12	Primary Oscillator
73	N/A	N/A	RC13	SOSCI/CN1/RC13	Secondary Oscillator
74	N/A	N/A	RC14	SOSCO/T1CK/CN0/RC14	Secondary Oscillator
64	N/A	N/A	RC15	OSC2/CLKO/RC15	Primary Oscillator
72	JD-02	25	RD00	SDO1/OC1/INT0/RD0	
76	JD-07	28	RD01	OC2/RD1	
77	JD-08	29	RD02	OC3/RD2	
78	JD-09	30	RD03	OC4/RD3	
81	JC-09	22	RD04	OC5/PMWR/CN13/RD4	
82	JC-08	21	RD05	PMRD/CN14/RD5	
83	N/A	N/A	RD06	ETXEN/PMD14/CN15/RD6	Ethernet PHY
84	JC-04	19	RD07	ETXCLK/PMD15/CN16/RD7	
68	N/A	N/A	RD08	RTCC/EMDIO/AEMDIO/IC1/RD8	Ethernet PHY
69	JD-01	24	RD09	SS1/IC2/RD9	
70	JD-04	27	RD10	SCK1/IC3/PMCS2/PMA15/RD10	
71	N/A	N/A	RD11	EMDC/AEMDC/IC4/PMCS1/PMA14/RD11	Ethernet PHY
79	JD-10	31	RD12	ETXD2/IC5/PMD12/RD12	
80	N/A	60	RD13	ETXD3/PMD13/CN19/RD13	USB Overcurrent detect
47	JE-01	32	RD14	AETXD0/SS1A/U1BRX/U1ACTS/CN20/RD14	
48	JE-04	35	RD15	AETXD1/SCK1A/U1BTX/U1ARTS/CN21/RD15	
93	JB-01	8	RE00	PMD0/RE0	
94	JB-02	9	RE01	PMD1/RE1	
98	JB-03	10	RE02	PMD2/RE2	
99	JB-04	11	RE03	PMD3/RE3	
100	JB-07	12	RE04	PMD4/RE4	
3	JB-08	13	RE05	PMD5/RE5	
4	JB-09	14	RE06	PMD6/RE6	
5	JB-10	15	RE07	PMD7/RE7	
18	JE-07	36	RE08	AERXD0/INT1/RE8	
19	JF-07	44	RE09	AERXD1/INT2/RE9	
87	N/A	N/A	RF00	C1RX/ETXD1/PMD11/RF0	Ethernet PHY

88	N/A	N/A	RF01	C1TX/ETXD0/PMD10/RF1	Ethernet PHY
52	JE-03	34	RF02	SDA1A/SDI1A/U1ARX/RF2	
51	N/A	N/A	RF03	USBID/RF3	USBID (USB-4)
49	JF-03	42	RF04	SDA3A/SDI3A/U3ARX/PMA9/CN17/RF4	
50	JF-02	41	RF05	SCL3A/SDO3A/U3ATX/PMA8/CN18/RF5	
53	JE-02	33	RF08	SCL1A/SDO1A/U1ATX/RF8	
40	JF-01	40	RF12	AC1RX/SS3A/U3BRX/U3ACTS/RF12	also CAN1 (JP-1)
39	JF-04	43	RF13	AC1TX/SCK3A/U3BTX/U3ARTS/RF13	also CAN1 (JP-2)
90	JC-02	17	RG00	C2RX/PMD8/RG0	
89	JC-03	18	RG01	C2TX/ETXERR/PMD9/RG1	
57	N/A	N/A	RG02	D+/RG2	D+ (USB-3)
56	N/A	N/A	RG03	D-/RG3	D- (USB-2)
10	BTN1	47	RG06	.../SCK2A/U2BTX/U2ARTS/PMA5/CN8/RG6	BTN1
11	BTN2	49	RG07	.../SDA2A/SDI2A/U2ARX/PMA4/CN9/RG7	BTN2
12	N/A	N/A	RG08	.../SCL2A/SDO2A/U2ATX/PMA3/CN10/RG8	Ethernet PHY
14	N/A	N/A	RG09	.../SS2A/U2BRX/U2ACTS/PMA2/CN11/RG9	Ethernet PHY
96	LD1	51	RG12	TRD1/RG12	LED1
97	LD2	52	RG13	TRD0/RG13	LED2
95	LD3	53	RG14	TRD2/RG14	LED3
1	LD4	54	RG15	AERXERR/RG15	LED4