



**DLP-RFID-
LP8C**
LEAD-FREE

8-Channel Reader/Writer

FEATURES:

- ISO15693, ISO14443A, ISO14443B Compatible
- Can read the UID/SID of up to 15 Tags Simultaneously
- 13.56MHz Reader/Writer
- 8 Channels for External Antenna Connections
- FCC/IC Modular Approvals in Place
- USB Port Powered from Windows, CE or Linux PC
- Both USB and RS232 Interfaces Provided
- USB Interface; No Driver Development Required for Windows, CE or Linux PC
- Operating Temperatures: 0°C to 70°C
- Dimensions: (L x W x H) 4.36" x 3.32" x 0.6"

APPLICATIONS INCLUDE:

- Real-Time Security
- Personal Identification
- Pharmaceutical Tracking
- Inventory/Asset Management & Tracking
- Library/Book Management & Tracking
- Baggage Tagging
- Sports Event Timing

1.0 INTRODUCTION

The DLP-RFID-LP8C is a low-cost, USB-powered module for reading from and writing to ISO15693, ISO14443A and ISO14443B intelligent RFID transponder tags via up to eight external antennas. It has the ability to both read and write tag user data in addition to reading the unique identifier (UID). All of the DLP-RFID-LP8C's electronics reside on a single, compact PCB; and all operational power is taken from the host Windows/Windows CE/Linux PC via the USB interface. Up to eight external antennas can be connected via reverse-polarity SMA connectors.

2.0 HARDWARE SETUP

The four jumpers provided on the DLP-RFID-LP8C module are used to select between the USB and RS232 interfaces. For RS232 interface operation, move the three jumpers to the RS and RS232 positions and remove JP3. For USB operation, move the three jumpers to the USB position and add jumper JP3.

If using the RS232 interface, connect the J3 wiring terminals to $\pm 8V$ to $\pm 12V$ serial signals typically found in the DB9, RS232 port connectors on a host PC. An external, regulated 5 volt power source must also be connected to J2.

If using USB, simply connect the DLP-RFID-LP8C to a host PC using the 5-pin mini-B USB connector CN1 and a compatible USB cable. All power and data are provided via the USB cable.

3.0 APPLICATION DEVELOPMENT

The serial interface for the DLP-RFID-LP8C operates at 115,200 baud, no parity, 8 data bits and 1 stop bit.

A demonstration GUI is provided with the purchase of a DLP-RFID-LP8C module that demonstrates the communications protocols. Using the Virtual COM Port USB drivers, the DLP-RFID-LP8C appears to the host PC (Windows, Linux, Mac) as an RS232 port. The GUI presents the actual control packets sent, and the reply data coming back from the DLP-RFID-LP8C as an aid to the software developer.

3.1 DEMONSTRATION GUI

The demonstration GUI is available as a free download from the DLP Design website. The URL for the download page is printed on the outer packaging of the DLP-RFID-LP8C.

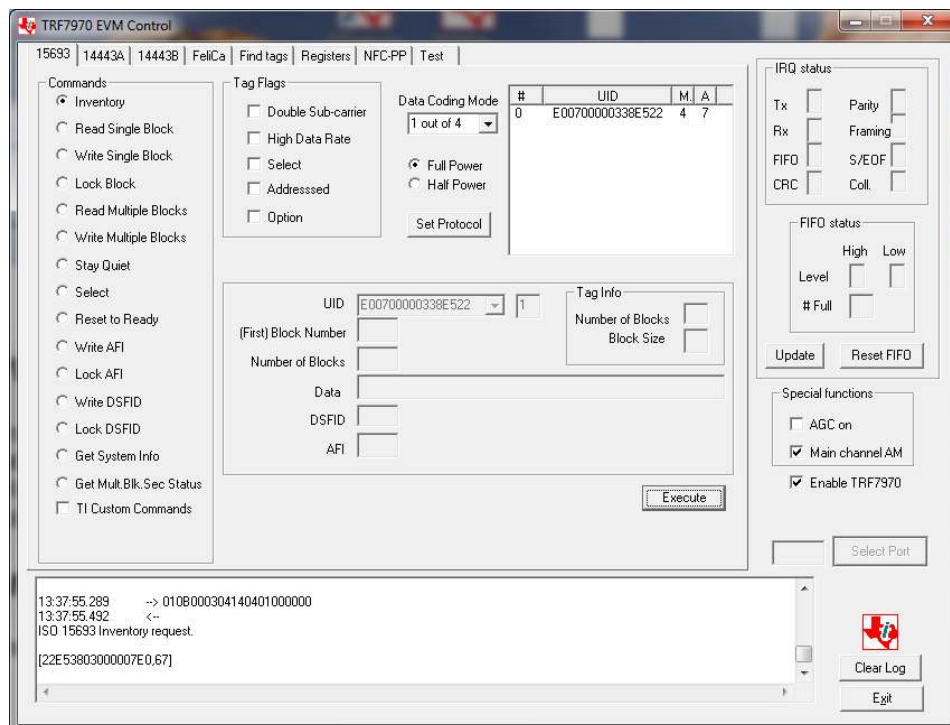

3.2 LP8C SPECIFIC COMMANDS

To select one of the 8 external antennas on the DLP-RFID-LP8C you must send the correct command packet (Ex: 010900030422F00000). To send this packet using the TI GUI, first make the connection to the DLP-RFID-LP8C, and then click on the Test tab. Enter a command packet as shown below and click on Send Raw. The LED associated with the antenna channel selected will light and successive tag reads will use that channel.

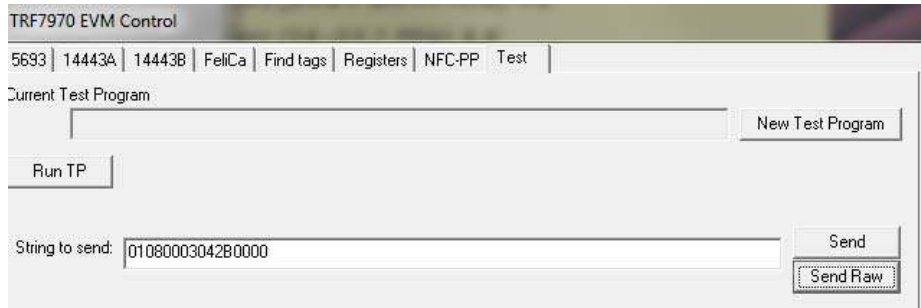

LP8C Specific commands:

Commands to activate 1 of the 8 Antenna Channels:

1. 010900030422F00000
2. 010900030423F00000
3. 010900030424F00000
4. 010900030425F00000
5. 010900030426F00000
6. 010900030427F00000
7. 010900030428F00000
8. 010900030429F00000

Read Opto-isolated inputs:

010900030435F00000

Write opto-isolated output 1 high:

010900030430F00000

Write opto-isolated output 1 low:

010900030431F00000

Write opto-isolated output 2 high:

010900030432F00000

Write opto-isolated output 2 low:

010900030433F00000

Issue Pass beep

010900030477F00000

Issue Fail Beep

010900030479F00000

3.3 LP8C OPERATING FIRMWARE

The source code for the firmware running in the DLP-RFID-LP8C reader (developed using Code Composer Studio) is available for download upon purchase of the DLP-RFID-LP8C from the DLP Design website.

4.0 MECHANICAL DIMENSIONS IN INCHES (MM)

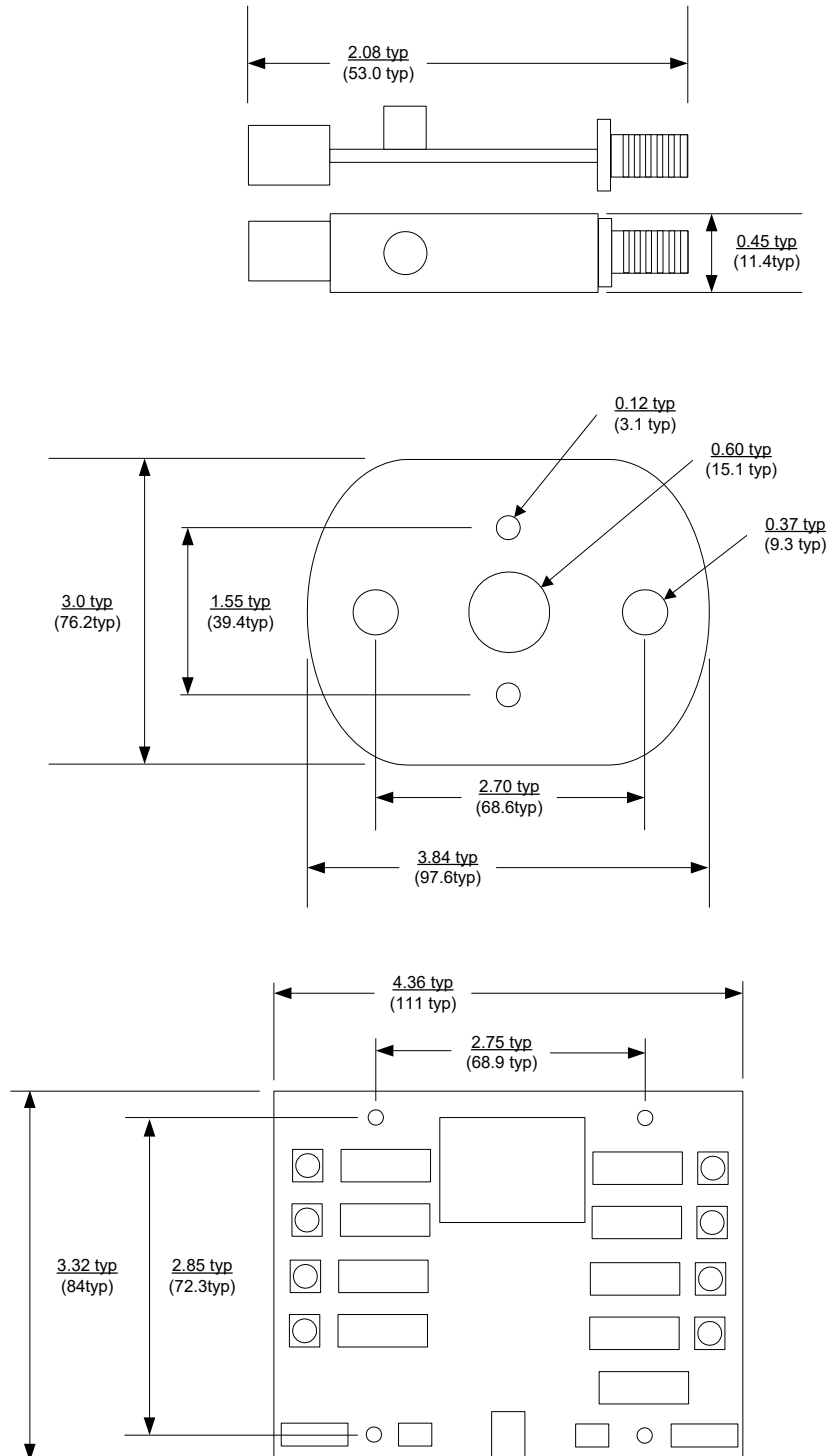

5.0 REGULATORY AGENCY CONSIDERATIONS

5.1 AGENCY IDENTIFICATION NUMBERS

Compliance with the appropriate regulatory agencies is essential in the deployment of all intentional radiators. DLP Design has obtained modular approval for this RF product such that an OEM need only meet a few basic requirements in order to utilize their end product under this approval. Corresponding agency identification numbers are listed below:

<u>PART NUMBER</u>	<u>US/FCC</u>	<u>CAN/IC</u>
DLP-RFID-LP8C	SX90LP8C	5675A-0LP8C

5.2 EXTERNAL ANTENNAS

The DLP-RFID1-LP8C is approved for use with external 50 Ohm loop/ferrite antennas that are resonant at 13.56MHz. Connection is made via reverse-polarity SMA connectors.

Two different antennas are available from DLP Design: the **DLP-FANT** and the **DLP-RFID-ANT**.



DLP-FANT



DLP-RFID-ANT

The DLP-FANT ferrite-based antenna provides a compact footprint for space-constrained applications and provides up to a 1.25-inch read range.

The DLP-FANT requires a coax cable with a reverse-polarity SMA connector at one end for connection to the DLP-RFID-LP8C reader. This coax cable is available in a 3-foot length from DLP Design under part number DLP-COAX1.

The DLP-RFID-ANT ships with an attached 15-foot coax cable with a reverse-polarity SMA connector and provides up to 4 inches of read range with larger (credit card size) tags.

5.3 FCC/IC REQUIREMENTS FOR MODULAR APPROVAL

Any changes or modifications to the DLP-RFID-LP8C's printed circuit board could void the user's authority to operate the equipment. Operation of an unapproved antenna could void the user's authority to operate the equipment.

5.4 WARNINGS

Operation is subject to the following two conditions: (1) This device may not cause harmful interference; and (2) this device must accept any interference received, including interference that may cause undesirable operation.

To reduce potential radio interference with other users, the antenna type and its gain should be so chosen that the equivalent isotropically-radiated power (e.i.r.p.) is not more than that permitted for successful communication.

This device is intended for use under the following conditions:

1. The transmitter module may not be co-located with any other transmitter or antenna; and,
2. The module is approved using the FCC "unlicensed modular transmitter approval" method.

As long as these two conditions are met, further transmitter testing will not be required. However, the OEM integrator is still responsible for testing their end product for any additional compliance measures necessitated by the installation of this module (i.e. digital device emissions, PC peripheral requirements, etc.).

Note: In the event that these conditions cannot be met (i.e. co-location with another transmitter), then the FCC authorization is no longer valid, and the corresponding FCC ID may *not* be used on the final product. Under these circumstances, the OEM integrator will be responsible for re-evaluating the end product (including the transmitter) and obtaining a separate FCC authorization.

5.5 OEM PRODUCT LABELING

The final end product must be labeled in a visible area with the following text:

"Contains TX FCC ID: SX90LP8C"

5.6 RF EXPOSURE

In order to comply with FCC RF exposure-compliance requirements, the antenna used for this transmitter must not be co-located or operating in conjunction with any other antenna or transmitter.

5.7 ADDITIONAL INFORMATION FOR OEM INTEGRATORS

The end user should NOT be provided with any instructions on how to remove or install the DLP-RFID-LP8C. This device has been pre-certified to operate with the antenna models listed below, or any other 50 Ohm, magnetic loop antenna that resonates at 13.56MHz.

- DLP Design Large Loop Antenna
- DLP Design Small Loop Antenna
- DLP Design Ferrite Antenna

6.0 DISCLAIMER

Neither the whole nor any part of the information contained herein nor the product described in this datasheet may be adapted or reproduced in any material or electronic form without the prior written consent of the copyright holder.

This product and its documentation are supplied on an as-is basis, and no warranty as to their suitability for any particular purpose is either made or implied. DLP Design will not accept any claim for damages whatsoever arising as a result of use or failure of this product. Your statutory rights are not affected.

This product or any variant of it is not intended for use in any medical appliance, device or system in which the failure of the product might reasonably be expected to result in personal injury.

This document provides preliminary information that may be subject to change without notice.

7.0 CONTACT INFORMATION

DLP Design, Inc.
1605 Roma Lane
Allen, TX 75013

Phone: 469-964-8027
Fax: 415-901-4859
Email: support@dlpdesign.com
Internet: <http://www.dlpdesign.com>

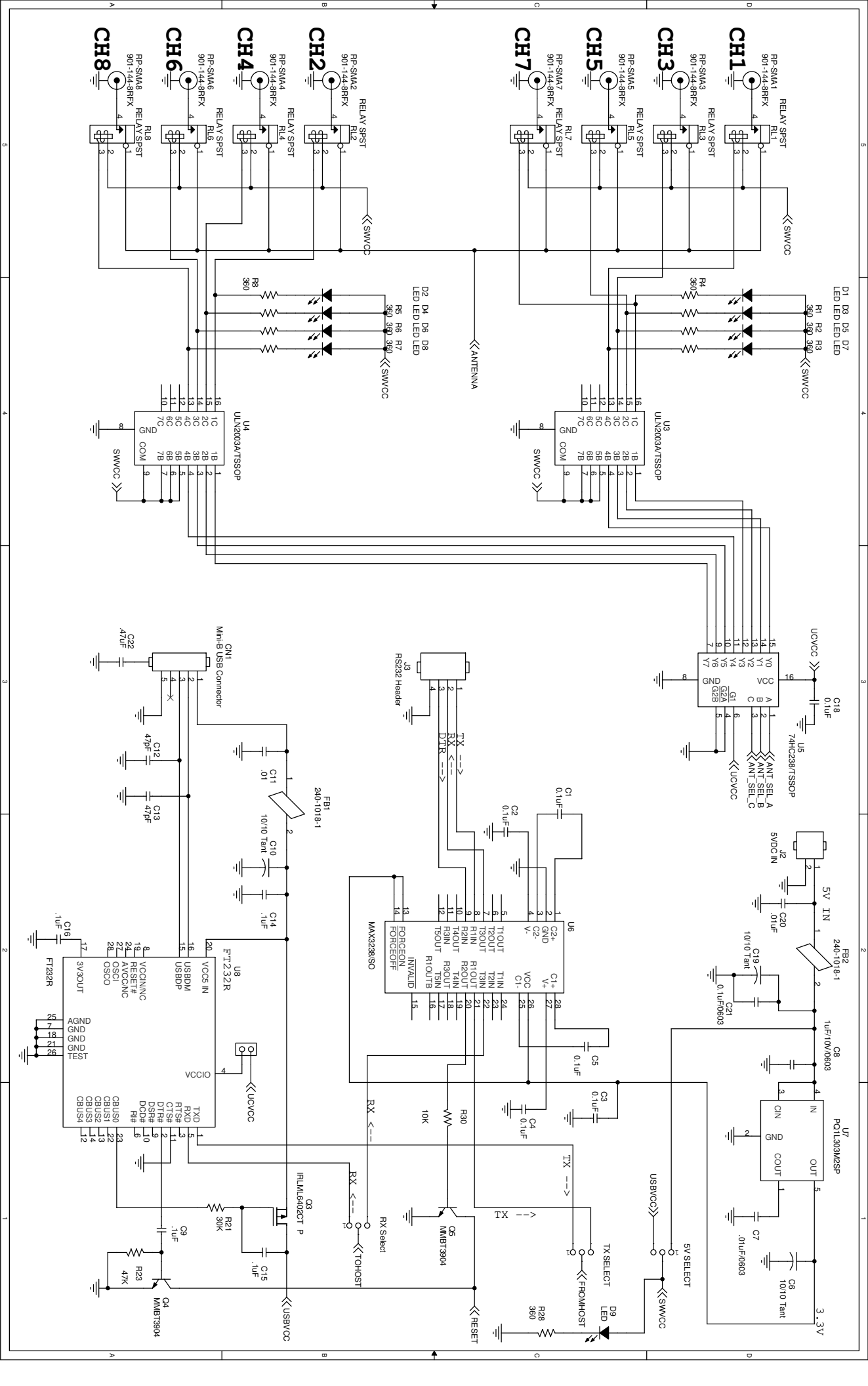

DLP-RFID-1P8C

Simplified Schematic

