



HAMMOND
MANUFACTURING™



ROLEC®

..protects.



Mr. Friedhelm Rose, Ms. Betty Rose, Mr. Matthias Rose.

Hammond Manufacturing is proud to be the exclusive North American sales partner of ROLEC Gehäuse-Systeme GmbH of Germany.

ROLEC was founded in 1987 by Mr. Friedhelm Rose and his son, Mr. Matthias Rose. Mr. Friedhelm Rose developed the first water and dust-tight enclosures over 40 years ago, establishing the very basis of the electronic enclosure industry in Germany. Following Mr. Friedhelm Rose's retirement, ROLEC is successfully managed by second generation of the Rose family, Mr. Matthias Rose and Ms. Betty Rose. ROLEC continues to offer innovative enclosure solutions of the highest quality, living up to their motto of "Enclosures are our passion."

Hammond Manufacturing carries an extensive inventory of ROLEC enclosure products in our 90,000 square foot North American distribution centre. ROLEC enclosure products are available through the complete Hammond Manufacturing distributor network.



Hammond North American Distribution Centre

INDEX

DIECAST ALUMINUM

aluCASE

Specifications.	4
R190 & R191 Series	5

aluNORM

Specifications.	6
R100 Series - Shallow Lid, Deep Body	7
R101 Series - Deep Lid, Shallow Body	8
R102 Series - Deep Lid, Deep Body.	9

conFORM

Specifications.	10
R110, R111 Series	11

handCASE

Specifications.	12
R270, R271 Series	13

EXTRUDED ALUMINUM

mobileCASE

Specifications.	14
R250, R251 Series	15
Accessories	16

NON-METALLIC

starCASE

Specifications.	18
R230 Series.	19

technoBOX

Specifications.	20
R220 Series.	21

technoCASE

R200, R201 Series - ABS Plastic	22
R210, R211 Series - Polycarbonate	23

polyTOP

Specifications	24
R132 Series.	25

polyDOOR

Specifications.	26
R130, R131 Series	27

aluCASE

Specifications

Diecast Aluminum



Key Features

- Modern, high quality instrument enclosure
- Material - Aluminum die-cast: GD SI 12 / DIN 1725
- Shallow lid, deep body
- Captive stainless steel lid screws
- Enclosure can be mounted after closing lid
- Integrated 1.7 mm recess in lid for membrane keypads and front panels
- Neoprene oil and petrol resistant - thermoplastic gasket standard. (-40°C up to +120°C)
- Clip-on design covers - to hide mounting & lid screws (plastic - polyoxymethylene) - grey RAL 7040
- Complete with lid captivation devices
- Degree of protection: NEMA 4X, IP67
- Textured polyester powder coat, grey RAL 7040. (can be supplied unpainted on special order)

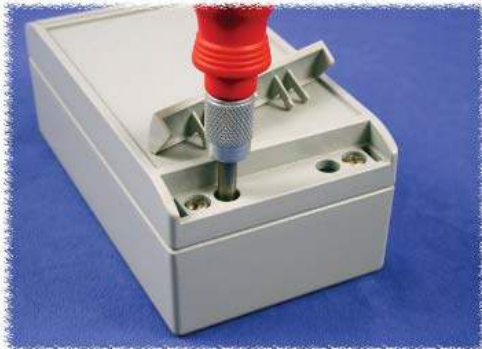

Enclosure can be installed after closing lid



Includes optional use lid captivation straps



Snap in design covers hide both lid screws and installation holes

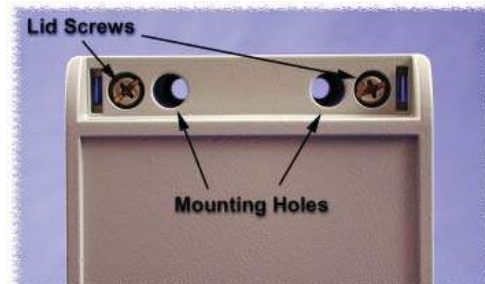

- Dual channel construction
- Mounting holes accessible with lid closed
- All holes outside of gasket seal.

aluCASE

R190 & R191 Series

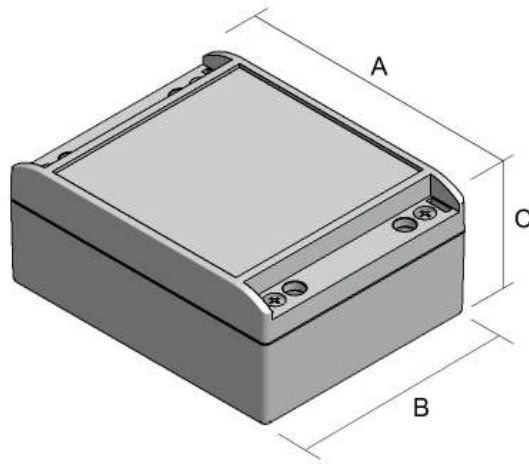

Diecast Aluminum

Part No.	Units	Width	Length	Height (Including Lid)
		A	B	C
R191-090-000	mm	90	120	60
	<i>inch</i>	3.5	4.7	2.4
R191-092-000	mm	90	160	60
	<i>inch</i>	3.5	6.3	2.4
R190-110-000	mm	110	140	60
	<i>inch</i>	4.3	5.5	2.4
R190-112-000	mm	110	200	60
	<i>inch</i>	4.3	7.9	2.4
R190-130-000	mm	130	160	70
	<i>inch</i>	5.1	6.3	2.8
R190-132-000	mm	130	220	70
	<i>inch</i>	5.1	8.7	2.8
R190-150-000	mm	150	180	60
	<i>inch</i>	5.9	7.1	2.4
R191-150-000	mm	150	180	90
	<i>inch</i>	5.9	7.1	3.5
R190-152-000	mm	150	260	60
	<i>inch</i>	5.9	10.2	2.4
R191-152-000	mm	150	260	90
	<i>inch</i>	5.9	10.2	3.5
R190-170-000	mm	170	200	60
	<i>inch</i>	6.7	7.9	2.4
R191-170-000	mm	170	200	90
	<i>inch</i>	6.7	7.9	3.5
R190-172-000	mm	170	280	60
	<i>inch</i>	6.7	11	2.4
R191-172-000	mm	170	280	90
	<i>inch</i>	6.7	11	3.5

aluNORM

Specifications

Key Features

- Material - Aluminum die-cast: G Al Si 12 / DIN 1775
- Shallow lid, deep body
- Captive stainless steel lid screws
- Neoprene oil and petrol resistant gasket standard. (-40°C up to +80°C)
- Degree of protection NEMA 4X, IP65, DIN 40050
- Temperature Range (-40°C up to +80°C)
- Single-channel Fastening System. Trouble-free turning 90° to 90° with square enclosures by synchronous arrangement of channels
- Special developed external mounting feet made from zinc-die-cast. Can be turned through 90°. The fastening holes have engagement lugs for this purpose. (See accessories)
- All sizes have inner blind holes. A mounting plate made of zinc-plated steel is available (See accessories)
- Textured polyester powder coat, light grey RAL7032. (can be supplied unpainted on special order)
- CSA certified, Type 4, for use with industrial control equipment



Diecast Aluminum

1 Screws and mounting holes outside of gasket seal...

2 Space saving single channel mounting (ie...same hole used for mounting enclosure through rear and for the lid), provides larger interior space than dual channel enclosures.

3 Captive stainless steel lid screws...

4 Enclosure holes threaded for easy installation and repetitive assembly & disassembly...

5 Internal mounting shelves placed along both sides of enclosure include blind holes and grounding screws...

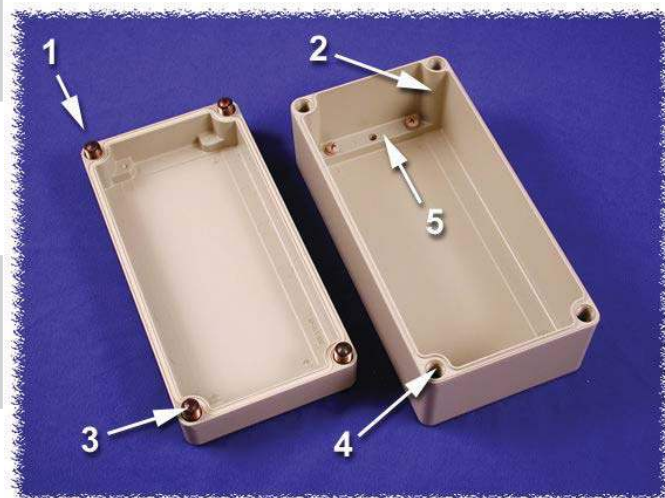

aluNORM

R100 Series - Shallow Lid, Deep Body

Diecast Aluminum

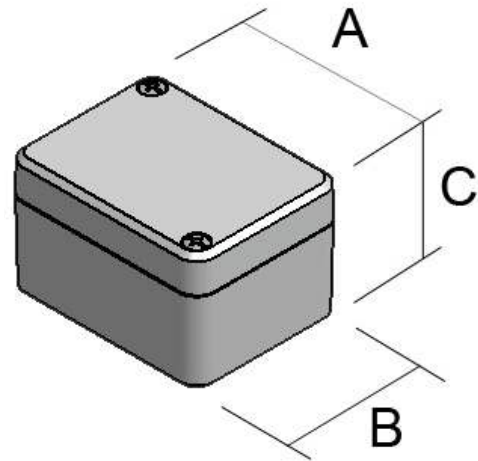

Part No.	Units	Width		Length		Height (Including Lid)	
		A	B	A	B	C	C
R100-060-000	mm	65	50			40	
	inch	2.6	2			1.6	
R100-062-000	mm	65	65			40	
	inch	2.6	2.6			1.6	
R100-064-000	mm	65	100			40	
	inch	2.6	4			1.6	
R100-066-000	mm	65	150			40	
	inch	2.6	6			1.6	
R100-080-000	mm	80	80			60	
	inch	3.2	3.2			2.4	
R100-082-000	mm	80	120			60	
	inch	3.2	4.8			2.4	
R100-084-000	mm	80	160			60	
	inch	3.2	6.4			2.4	
R100-100-000	mm	100	100			80	
	inch	4	4			3.2	
R100-102-000	mm	100	150			80	
	inch	4	6			3.2	
R100-104-000	mm	100	200			80	
	inch	4	8			3.2	
R100-120-000	mm	120	120			100	
	inch	4.8	4.8			4	
R100-122-000	mm	120	180			100	
	inch	4.8	7.2			4	
R100-124-000	mm	120	240			100	
	inch	4.8	9.6			4	

Part No.	Units	Width		Length		Height (Including Lid)	
		A	B	A	B	C	C
R100-160-000	mm	160	160			100	
	inch	6.4	6.4			4	
R100-162-000	mm	160	240			100	
	inch	6.4	9.6			4	
R100-164-000	mm	160	320			100	
	inch	6.4	12.8			4	
R100-166-000	mm	160	480			100	
	inch	6.4	19.2			4	
R100-200-000	mm	200	200			120	
	inch	8	8			4.8	
R100-202-000	mm	200	300			120	
	inch	8	12			4.8	
R100-204-000	mm	200	400			120	
	inch	8	16			4.8	
R100-240-000	mm	240	240			120	
	inch	9.6	9.6			4.8	
R100-242-000	mm	240	360			120	
	inch	9.6	14.4			4.8	
R100-244-000	mm	240	480			120	
	inch	9.6	19.2			4.8	
R100-320-000	mm	320	320			120	
	inch	12.8	12.8			4.8	
R100-322-000	mm	320	480			120	
	inch	12.8	19.2			4.8	
R100-324-000	mm	320	640			120	
	inch	12.8	25.6			4.8	

aluNORM

R101 Series - Deep Lid, Shallow Body

Diecast Aluminum

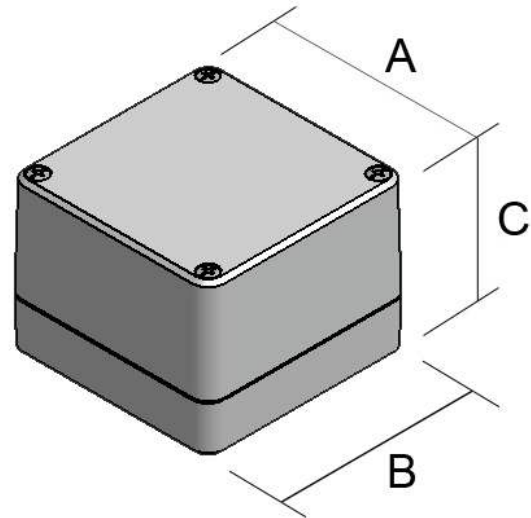

Part No.	Units	Width		Length		Height (Including Lid)	
		A	B	A	B	C	C
R101-080-000	mm	80	80			60	
	inch	3.2	3.2			2.4	
R101-082-000	mm	80	120			60	
	inch	3.2	4.8			2.4	
R101-084-000	mm	80	160			60	
	inch	3.2	6.4			2.4	
R101-100-000	mm	100	100			80	
	inch	4	4			3.2	
R101-102-000	mm	100	150			80	
	inch	4	6			3.2	
R101-104-000	mm	100	200			80	
	inch	4	8			3.2	
R101-120-000	mm	120	120			100	
	inch	4.8	4.8			4	
R101-122-000	mm	120	180			100	
	inch	4.8	7.2			4	
R101-124-000	mm	120	240			100	
	inch	4.8	9.6			4	
R101-160-000	mm	160	160			100	
	inch	6.4	6.4			4	
R101-162-000	mm	160	240			100	
	inch	6.4	9.6			4	

Part No.	Units	Width		Length		Height (Including Lid)	
		A	B	A	B	C	C
R101-164-000	mm	160	320			100	
	inch	6.4	12.8			4	
R101-166-000	mm	160	480			100	
	inch	6.4	19.2			4	
R101-200-000	mm	200	200			120	
	inch	8	8			4.8	
R101-202-000	mm	200	300			120	
	inch	8	12			4.8	
R101-204-000	mm	200	400			120	
	inch	8	16			4.8	
R101-240-000	mm	240	240			120	
	inch	9.6	9.6			4.8	
R101-242-000	mm	240	360			120	
	inch	9.6	14.4			4.8	
R101-244-000	mm	240	480			120	
	inch	9.6	19.2			4.8	
R101-320-000	mm	320	320			120	
	inch	12.8	12.8			4.8	
R101-322-000	mm	320	480			120	
	inch	12.8	19.2			4.8	
R101-324-000	mm	320	640			120	
	inch	12.8	25.6			4.8	

aluNORM

R102 Series - Deep Lid, Deep Body

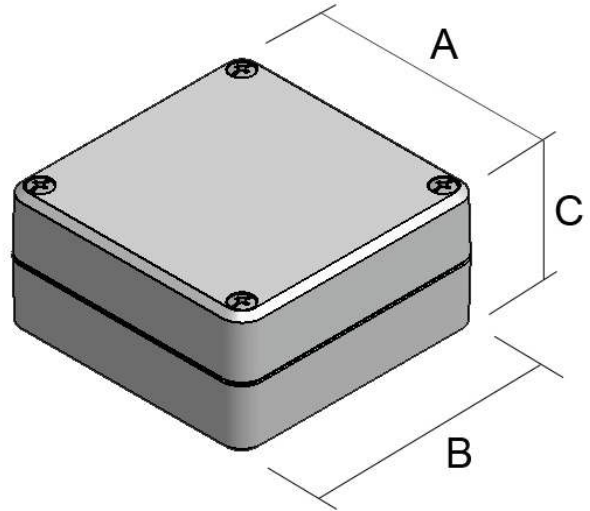

Diecast Aluminum



Part No.	Units	Width		Length		Height (Including Lid)	
		A	B	B	C	C	C
R102-080-000	mm	80	80			40	
	inch	3.2	3.2			1.6	
R102-082-000	mm	80	120			40	
	inch	3.2	4.8			1.6	
R102-084-000	mm	80	160			40	
	inch	3.2	6.4			1.6	
R102-100-000	mm	100	100			54	
	inch	4	4			2.2	
R102-102-000	mm	100	150			54	
	inch	4	6			2.2	
R102-104-000	mm	100	200			54	
	inch	4	8			2.2	
R102-120-000	mm	120	120			66	
	inch	4.8	4.8			2.6	
R102-122-000	mm	120	180			66	
	inch	4.8	7.2			2.6	
R102-124-000	mm	120	240			66	
	inch	4.8	9.6			2.6	
R102-160-000	mm	160	160			66	
	inch	6.4	6.4			2.6	
R102-162-000	mm	160	240			66	
	inch	6.4	9.6			2.6	

Part No.	Units	Width		Length		Height (Including Lid)	
		A	B	B	C	C	C
R102-164-000	mm	160	320			66	
	inch	6.4	12.8			2.6	
R102-166-000	mm	160	480			66	
	inch	6.4	19.2			2.6	
R102-200-000	mm	200	200			80	
	inch	8	8			3.2	
R102-202-000	mm	200	300			80	
	inch	8	12			3.2	
R102-204-000	mm	200	400			80	
	inch	8	16			3.2	
R102-240-000	mm	240	240			80	
	inch	9.6	9.6			3.2	
R102-242-000	mm	240	360			80	
	inch	9.6	14.4			3.2	
R102-244-000	mm	240	480			80	
	inch	9.6	19.2			3.2	
R102-320-000	mm	320	320			80	
	inch	12.8	12.8			3.2	
R102-322-000	mm	320	480			80	
	inch	12.8	19.2			3.2	
R102-324-000	mm	320	640			80	
	inch	12.8	25.6			3.2	

conFORM

Specifications

Key Features

- Material - Aluminum die-cast: G Al Si 12 / DIN 1775
- Shallow lid, deep body
- Captive stainless steel lid screws
- Neoprene oil and petrol resistant gasket standard. (-40°C up to +80°C)
- EMI/RFI gasket is NOT required as lid to box connection is INSIDE the gasket seal. A patented system with special designed "teeth" in the enclosure bottom provide a lasting and corrosion secure shield.
- Degree of protection NEMA 4X, IP66, DIN 40050
- Temperature Range (-40°C up to +80°C)
- Separate channel system (outside the seal)
- Specially developed external mounting feet made from zinc-die-cast. Can be turned through 90°. The fastening holes have engagement lugs for this purpose.
- All sizes have inner blind holes. A mounting plate made of zinc-plated steel is available
- Textured polyester powder coat, light beige/grey RAL 7032. (can be supplied unpainted on special order)
- CSA certified, Type 4, for use with industrial control equipment



Diecast Aluminum

1

EMI/RFI enclosure body connection --to lid (see #2 right) is made INSIDE the gasket seal (see #3). This eliminates expensive conducting gaskets and the corrosion problems that can appear later...

2

Lid EMI/RFI edge (link here to lid close up) extends into enclosure and contacts "teeth" (see #1) in enclosure body for a positive contact...

3

Gasket (thermoplastic, forprene, silicon free material) outside of EMI/RFI contact points and inside of lid & mounting holes. No need for expensive conducting gasket (see #1)...

4

Screws and mounting holes outside of gasket seal...

5

Internal mounting shelves placed along both sides of enclosure include blind holes and grounding screws. There are many mounting holes for self tapping screws in both the enclosure & the lid. Can also be used for mounting P.C. boards or plates..

6

Enclosure holes threaded for easy installation and repetitive assembly & disassembly...



conFORM
R110, R111 Series

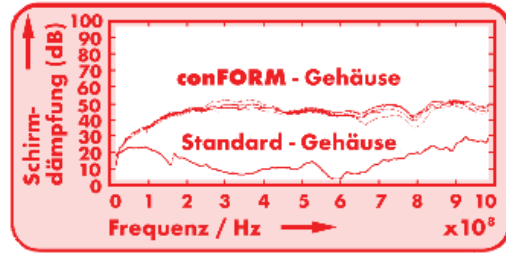
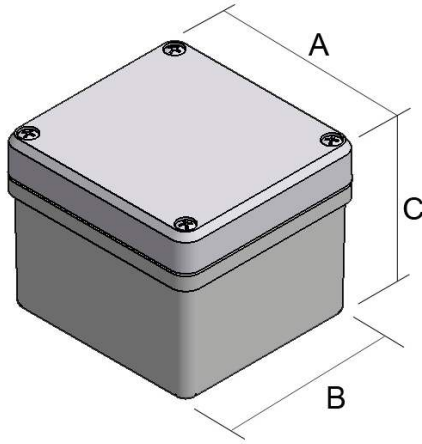

Diecast Aluminum

Part No.	Units	Width	Length	Height
		A	B	(Including Lid)
R111-081-000	mm	84	79	44
	inch	3.3	3.1	1.8
R110-081-000	mm	84	79	67
	inch	3.3	3.1	2.7
R111-082-000	mm	84	129	44
	inch	3.3	5.2	1.8
R110-082-000	mm	84	129	67
	inch	3.3	5.2	2.7
R111-083-000	mm	84	179	44
	inch	3.3	7.2	1.8
R110-083-000	mm	84	179	67
	inch	3.3	7.2	2.7
R111-121-000	mm	125.5	127.5	60
	inch	5	5	2.4
R110-121-000	mm	125.5	127.5	90
	inch	5	5	3.6
R111-123-000	mm	125.5	225.5	60
	inch	5	9	2.4
R110-123-000	mm	125.5	225.5	90
	inch	5	9	3.6
R111-161-000	mm	166	166	60
	inch	6.5	6.5	2.4
R110-161-000	mm	166	166	100
	inch	6.5	6.5	4
R111-162-000	mm	166	266	66
	inch	6.5	10.5	2.6
R110-162-000	mm	166	266	100
	inch	6.5	10.5	4

handCASE

Specifications

Key Features

- Designed as a heavy duty hand held - manufactured in diecast aluminum for superior strength.
- Ergonomic design for extended handling without fatigue.
- Two-part styled lid construction. Top half includes smooth recessed area for membrane, label or silkscreen.
- Top half powder painted in a silver grey and the bottom half is powder painted in black.
- P.C. board standoffs are cast into both halves of the enclosure. Mounting screws included.
- The two smaller sizes include an ABS plastic battery compartment installed and gasketed access bottom lid.
- Gasketed lid with two piece "tongue & groove" construction provides protection against access of oil, dust and water.
- Lid screws are stainless steel.
- Designed to meet IP66.



Diecast Aluminum



Assembled View



Open View
(Bottom)



Assembled View
(Bottom)



Open View
(Top)

handCASE
R270, R271 Series

Diecast Aluminum

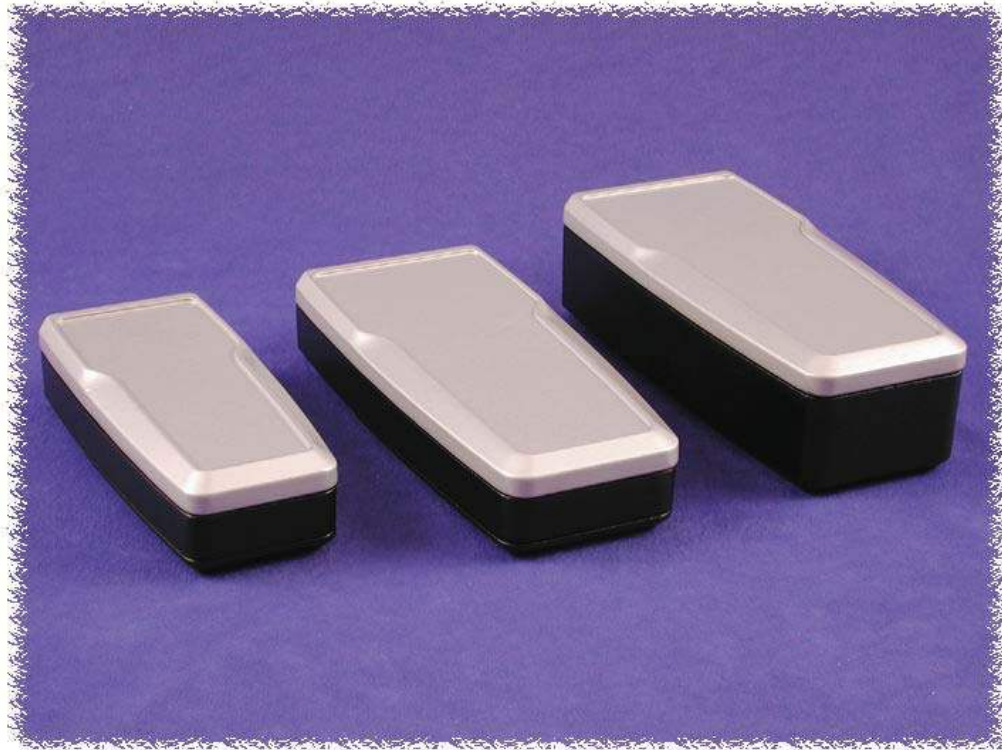

Part Number	Battery Compartment	Units	Length		Width		Height (Including Lid)	Weight
			A	B	B	C		
R270-080-000	Yes	Inch <i>mm</i>	7.09 <i>180</i>	3.15 <i>80</i>	3.15 <i>80</i>	1.67 <i>42.4</i>	1 lb. 1.1 oz.	
R270-100-000	Yes	Inch <i>mm</i>	8.66 <i>220</i>	3.94 <i>100</i>	3.94 <i>100</i>	1.67 <i>42.4</i>	1 lb.7.1 oz.	
R271-100-000	No	Inch <i>mm</i>	8.66 <i>220</i>	3.94 <i>100</i>	3.94 <i>100</i>	2.46 <i>62.4</i>	1 lb. 8.3 oz.	

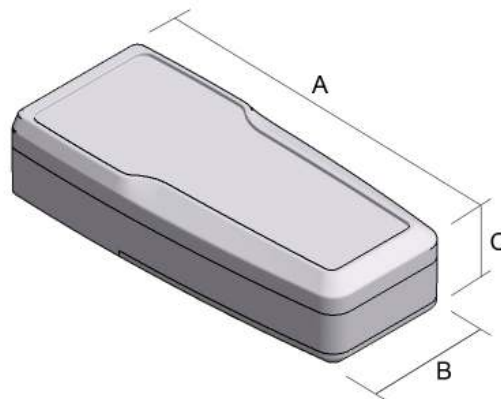

mobileCASE

Specifications

Key Features

- Modern and ergonomic design
- Designed to house P.C. boards (not included) or equipment for mobile use
- Sized for standard Eurocards
- P.C. boards mount horizontally by sliding into internal slots extruded into the enclosure body
- Internal height 1.06" (27mm)
- Rugged body constructed from extruded aluminum with diecast aluminum ends
- Silver anodized finish
- Choice of two versions - one piece closed or two piece "clam shell"
- One piece version is rated to IP 65 (with gasketed end plates below)
- Two piece version is rated to IP 54 (with gasketed end plates below)

Extruded Aluminum



Diecast End Plates Attached
(Assembled View)



Example Application
(Assembled View)

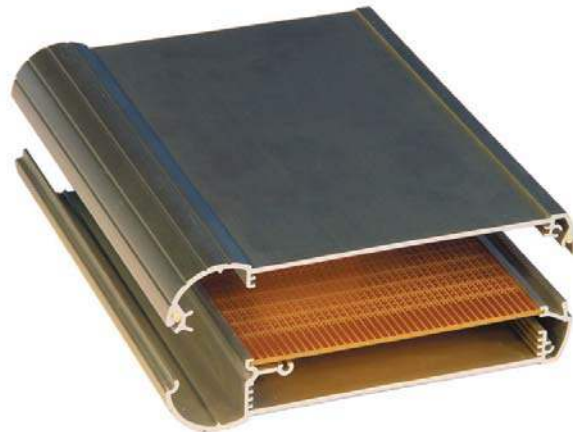

With P.C. Board Mounted
(Two piece version)

mobileCASE

R250, R251 Series

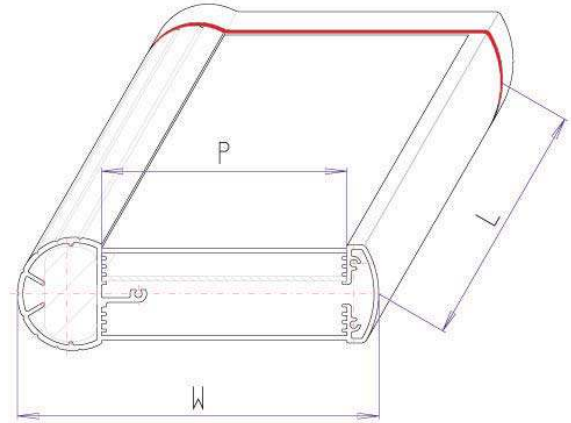

Extruded Aluminum

Aluminum Extrusion

Part Number	Version	Units	Length	Width	Profile Width
			L	W	P
R250-080-120	One Piece	inch	4.72	4.65	3.15
R251-080-120	Two Piece	mm	120	118	80
R250-080-160	One Piece	inch	6.3	4.65	3.15
R251-080-160	Two Piece	mm	160	118	80
R250-100-160	One Piece	inch	6.3	5.43	3.94
R251-100-160	Two Piece	mm	160	138	100
R250-100-200	One Piece	inch	7.87	5.43	3.94
R251-100-200	Two Piece	mm	200	138	100
R250-130-180	One Piece	inch	7.09	6.61	5.12
R251-130-180	Two Piece	mm	180	168	130
R250-130-240	One Piece	inch	9.45	6.61	5.12
R251-130-240	Two Piece	mm	240	168	130

mobileCASE

Accessories

Cover Plates & Gasket

- Choose either Flat or Collar (used for accepting cables or batteries) style end plates
- Heavy duty diecast aluminum
- Painted with textured black powder paint (RAL 9005)
- Includes cover plates, thermoplastic black gaskets and mounting hardware
- Sold in Pairs



Flat Style



Collar Style



Flat Style (Top)
Collar Style (Bottom)

Extruded Aluminum

Part Number	Style	Use With Aluminum Extrusion Part Number
R580-080-000	Flat	R250-080-120 or R251-080-120 or R250-080-160 or R251-080-160
R580-100-000	Flat	R250-100-160 or R251-100-160 or R250-100-200 or R251-100-200
R580-130-000	Flat	R250-130-180 or R251-130-180 or R250-130-240 or R251-130-240
R581-080-000	Collar	R250-080-120 or R251-080-120 or R250-080-160 or R251-080-160
R581-100-000	Collar	R250-100-160 or R251-100-160 or R250-100-200 or R251-100-200
R581-130-000	Collar	R250-130-180 or R251-130-180 or R250-130-240 or R251-130-240

Cable Gland & Battery Kits

Part Number	Use With Aluminum Extrusion Part Number
R584-002-000	Two Battery Holder (AA Size)
R584-004-000	Four Battery Holder (AA Size)
R585-000-000	Cable Gland Adaptor Kit



Cable Gland & Battery Kits



Battery Kits

mobileCASE

Accessoires

Variable Cover Plates & Gasket

- Heavy duty diecast aluminum
- Painted with textured black powder paint (RAL 9005)
- Includes cover plates, thermoplastic black gaskets and mounting hardware
- Sold in set to connect two extrusions side by side

Part Number	Style	Used To Join Aluminum Extrusion Series
R588-080-080	Variable	R250-080 or R251-080 TO R250-080 or R251-080
R588-080-100	Variable	R250-080 or R251-080 TO R250-100 or R251-100
R588-080-130	Variable	R250-080 or R251-080 TO R250-130 or R251-130
R588-100-100	Variable	R250-100 or R251-100 TO R250-100 or R251-100
R588-100-130	Variable	R250-100 or R251-100 TO R250-130 or R251-130
R588-130-130	Variable	R250-130 or R251-130 TO R250-130 or R251-130



Variable Plate In Use



Variable Style

Extruded Aluminum

Shoulder Strap & Protective Caps

- Allows unit to be used in rough environments, indoors or out
- Nylon straps & TPE shoulder pad and end caps
- Enclosure not included

Part Number	Use With Aluminum Extrusion Part Number
R583-080-000	R250-080-120 or R251-080-120 or R250-080-160 or R251-080-160
R583-100-000	R250-100-160 or R251-100-160 or R250-100-200 or R251-100-200
R583-130-000	R250-130-180 or R251-130-180 or R250-130-240 or R251-130-240



Shoulder Strap & Protective Caps



Assembled View

starCASE - ABS Flame Retardant Plastic

Specifications

Application

- ABS flame retardant plastic enclosures are designed for use as instrument enclosures, electrical junction boxes or terminal wiring enclosures where metallic enclosures are not suitable.
- Modern design with rounded edges & hidden assembly screws
- Provide outstanding protection against dust, oil and pressurized water.
- Impervious to atmospheric and marine corrosion.

Standards

- Meets NEMA Type 4, 4X, 12 and 13
- Meets IP66
- ABS Plastic material: UL94 V-0 1.6mm flammability Rating

Construction

- Molded in ABS fire retardant plastic.
- Lid is recessed for membrane keypads or labels.
- Includes plastic lid supports (to keep lid captive to box).
- Separate mounting channels & lid channels all outside of the interior & gasket seal.
- Recessed silicon gasket with tongue and groove construction.
- Captive stainless steel lid screws are provided.

Finish

- Light grey RAL 7035 - light texture



Removable hinged design covers hide both lid screws and installation holes



Includes optional use lid captivation straps



Enclosure can be installed after closing lid

Non-Metallic

starCASE - ABS Fire Retardant Plastic

R230 Series



Application

- Dual channel construction
- Mounting holes accessible with lid closed
- All holes outside of gasket seal.

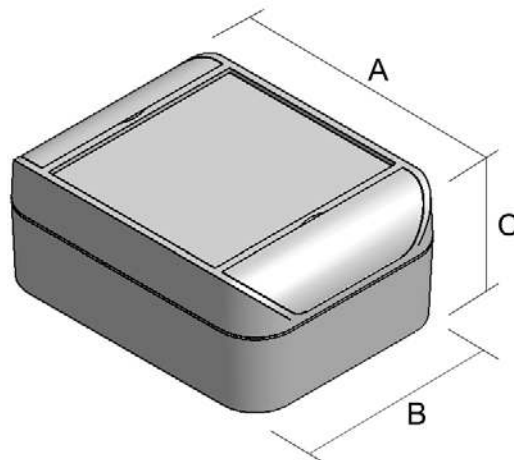

Part No.	Units	Length		Height
		A	B	(Including Lid)
R230-090-000	mm	120	90	50
	inch	4.72	3.54	1.97
R230-092-000	mm	160	90	50
	inch	6.3	3.54	1.97
R230-112-000	mm	200	110	60
	inch	7.87	4.33	2.36
R230-130-000	mm	160	130	60
	inch	6.3	5.12	2.36
R230-172-000	mm	280	170	60
	inch	11.02	6.69	2.36

Non-Metallic

technoBOX - ABS Plastic

Specifications

Application

- ABS plastic enclosures are designed for use as instrument enclosures, electrical junction boxes or terminal wiring enclosures where metallic enclosures are not suitable.
- Modern design with slanted top edges
- Provide outstanding protection against dust, oil and pressurized water.
- Impervious to atmospheric and marine corrosion.

Standards

- NEMA Type 4, 4X, 12 and 13
- IP66
- UL94 HB Flammability Rating

Construction

- Molded in ABS plastic.
- Separate mounting channels & lid channels.
- Recessed polyurethane gasket with tongue and groove construction.
- Interlocking flange on lid and bottom sections.
- Captive stainless steel lid screws are provided.
- Cover screws fasten into pre-threaded holes.



Finish

- Light grey RAL 7035

Non-Metallic

1 Separate screw channels outside of the gasket seal (lid screws & enclosure mounting screws)...

2 There are many mounting posts for self tapping screws in both the enclosure & the lid. Can also be used for mounting P.C. boards or plates..

3 Thermoplastic forpene gasket...

4 Enclosure mounts through channel and bottom holes, concealed when lid is attached...



technoBOX - ABS Plastic

R220 Series

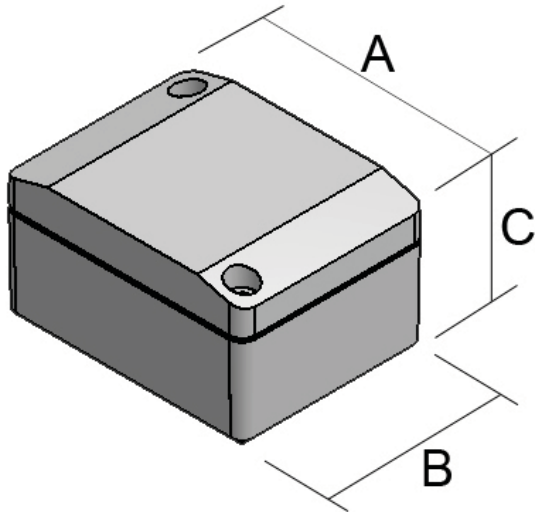

Non-Metallic

Part No.	Units	Length		Width		Height (Including Lid)	
		A	B	B	C	C	
R220-060-000	mm	66	51	51	35	35	
	<i>inch</i>	2.6	2	2	1.4	1.4	
R220-080-000	mm	83	81	81	60	60	
	<i>inch</i>	3.3	3.2	3.2	2.4	2.4	
R220-082-000	mm	121	81	81	60	60	
	<i>inch</i>	4.8	3.2	3.2	2.4	2.4	
R220-084-000	mm	161	81	81	60	60	
	<i>inch</i>	6.3	3.2	3.2	2.4	2.4	
R220-102-000	mm	151	101	101	60	60	
	<i>inch</i>	5.9	4	4	2.4	2.4	
R220-104-000	mm	201	101	101	60	60	
	<i>inch</i>	7.9	4	4	2.4	2.4	
R220-120-000	mm	123	121	121	80	80	
	<i>inch</i>	4.8	4.8	4.8	3.2	3.2	
R220-122-000	mm	201	121	121	80	80	
	<i>inch</i>	7.9	4.8	4.8	3.2	3.2	
R220-160-000	mm	161	161	161	80	80	
	<i>inch</i>	6.3	6.3	6.3	3.2	3.2	
R220-162-000	mm	241	161	161	80	80	
	<i>inch</i>	9.9	6.3	6.3	3.2	3.2	

technoCASE

R200, R201 Series - ABS Plastic

Application

- ABS plastic enclosures are designed for use as instrument enclosures, electrical junction boxes or terminal wiring enclosures where metallic enclosures are not suitable.
- Provide outstanding protection against dust, oil and pressurized water.
- Impervious to atmospheric and marine corrosion.

Standards

- NEMA Type 4, 4X, 12 and 13
- IEC 60529, IP66
- UL94 HB Flammability Rating

Construction

- Molded in ABS plastic.
- Unique reversible bottom and cover section.
- Separate mounting channels provide access to rear mounting position without opening the enclosure.
- Recessed polyurethane gasket with tongue and groove construction.
- Interlocking flange on cover and bottom sections.
- Captive stainless steel cover screws are provided.
- Cover screws fasten into pre-threaded holes.
- Unique snap on screw covers hide the cover fastening screws for a highly finished appearance.



Finish

- Light grey RAL 7035
- Front plates, Internal Hinges, Mounting Feet and P.C. Board Supports available

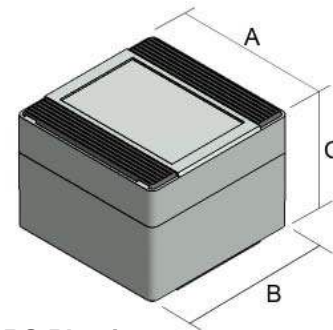

Non-Metallic

Shallow Depth - ABS Plastic

Part No.	Units	Width		Height
		A	B	(Including Lid) C
R200-080-000	mm	80	80	60
	inch	3.2	3.2	2.4
R200-082-000	mm	80	120	60
	inch	3.2	4.8	2.4
R200-084-000	mm	80	160	60
	inch	3.2	6.4	2.4
R200-086-000	mm	80	240	60
	inch	3.2	9.6	2.4
R200-120-000	mm	120	120	60
	inch	4.8	4.8	2.4
R200-122-000	mm	120	200	60
	inch	4.8	8	2.4
R200-124-000	mm	120	240	60
	inch	4.8	9.6	2.4
R200-160-000	mm	160	160	60
	inch	6.4	6.4	2.4
R200-162-000	mm	160	240	60
	inch	6.4	9.6	2.4

Deep Depth - ABS Plastic

Part No.	Units	Width		Height
		A	B	(Including Lid) C
R201-080-000	mm	80	80	80
	inch	3.2	3.2	3.2
R201-082-000	mm	80	120	80
	inch	3.2	4.8	3.2
R201-084-000	mm	80	160	80
	inch	3.2	6.4	3.2
R201-086-000	mm	80	240	80
	inch	3.2	9.6	3.2
R201-120-000	mm	120	120	90
	inch	4.8	4.8	3.6
R201-122-000	mm	120	200	90
	inch	4.8	8	3.6
R201-124-000	mm	120	240	90
	inch	4.8	9.6	3.6
R201-160-000	mm	160	160	90
	inch	6.4	6.4	3.6
R201-162-000	mm	160	240	90
	inch	6.4	9.6	3.6

technoCASE - Polycarbonate

R210, R211 Series - Polycarbonate

Application

- Polycarbonate enclosures are designed for use as instrument enclosures, electrical junction boxes or terminal wiring enclosures where metallic enclosures are not suitable.
- Provides outstanding protection against dust, oil and pressurized water.
- Impervious to atmospheric and marine corrosion.

Standards

- NEMA Type 4, 4X, 12 and 13
- IEC 60529, IP65
- UL94 HB Flammability Rating

Construction

- Molded in Polycarbonate.
- Unique reversible bottom and cover section.
- Separate mounting channels provide access to rear mounting position without opening the enclosure.
- Recessed polyurethane gasket with tongue and groove construction.
- Interlocking flange on cover and bottom sections.
- Captive stainless steel cover screws are provided.
- Cover screws fasten into pre-threaded holes.
- Unique snap on screw covers hide the cover fastening screws for a highly finished appearance.



Finish

- Light grey RAL 7035
- Front plates, Internal Hinges, Mounting Feet and P.C. Board Supports available

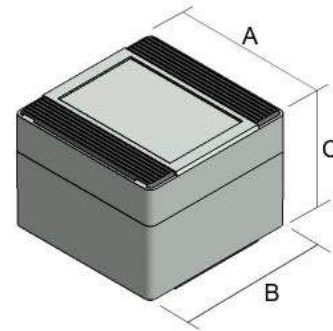

Non-Metallic

Shallow Depth - Polycarbonate

Part No.	Units	Width		Height (Including Lid)
		A	B	
R210-080-000	mm	80	80	60
	inch	3.2	3.2	2.4
R210-082-000	mm	80	120	60
	inch	3.2	4.8	2.4
R210-084-000	mm	80	160	60
	inch	3.2	6.4	2.4
R210-086-000	mm	80	240	60
	inch	3.2	9.6	2.4
R210-120-000	mm	120	120	60
	inch	4.8	4.8	2.4
R210-122-000	mm	120	200	60
	inch	4.8	8	2.4
R210-124-000	mm	120	240	60
	inch	4.8	9.6	2.4
R210-160-000	mm	160	160	60
	inch	6.4	6.4	2.4
R210-162-000	mm	160	240	60
	inch	6.4	9.6	2.4

Deep Depth - Polycarbonate

Part No.	Units	Width		Height (Including Lid)
		A	B	
R211-080-000	mm	80	80	80
	inch	3.2	3.2	3.2
R211-082-000	mm	80	120	80
	inch	3.2	4.8	3.2
R211-084-000	mm	80	160	80
	inch	3.2	6.4	3.2
R211-086-000	mm	80	240	80
	inch	3.2	9.6	3.2
R211-120-000	mm	120	120	90
	inch	4.8	4.8	3.6
R211-122-000	mm	120	200	90
	inch	4.8	7	3.6
R211-124-000	mm	120	240	90
	inch	4.8	9.6	3.6
R211-160-000	mm	160	160	90
	inch	6.4	6.4	3.6
R211-162-000	mm	160	240	90
	inch	6.4	9.6	3.6

polyTOP - Polyester

Specifications



Non-Metallic

Application

- Designed for use as instrument enclosures, electrical junction boxes or terminal wiring enclosures.
- Provides outstanding protection against dust, oil and pressurized water.
- Impervious to atmospheric and marine corrosion.

Standards

- NEMA Type 1, 2, 3, 3R, 4, 4X, 5, 12 and 13
- IEC 60529, IP66
- VO Flammability Rating
- CSA certified, Type 4, for use with industrial control equipment

Construction

- Two piece molded fiberglass reinforced polyester construction.
- Captive polyfibre cover screws are provided with a standard slot head.
- Cover screws fasten into pre-threaded holes.
- The threaded cover screw holes also provide single channel access to rear mounting positions.
- Recessed neoprene gasket with tongue and groove construction is oil and petroleum resistant.
- Threaded stainless steel inserts provide for internal mounting.

Finish

- Light beige RAL 7032, Pantone 413

polyTOP - Polyester

R132 Series

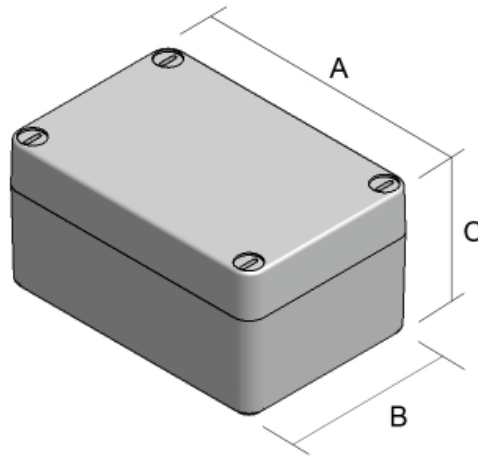

Part No.	Units	Width	Length	Height (Including Lid)
		A	B	C
R132-080-000	mm	82	82	60
	<i>inch</i>	3.3	3.3	2.4
R132-082-000	mm	82	122	60
	<i>inch</i>	3.3	4.9	2.4
R132-084-000	mm	82	162	60
	<i>inch</i>	3.3	6.5	2.4
R132-100-000	mm	102	102	81
	<i>inch</i>	4.1	4.1	3.2
R132-102-000	mm	102	152	81
	<i>inch</i>	4.1	6.1	3.2
R132-104-000	mm	102	202	81
	<i>inch</i>	4.1	8.1	3.2
R132-120-000	mm	124	124	100
	<i>inch</i>	4.9	4.9	4
R132-122-000	mm	124	184	100
	<i>inch</i>	4.9	7.2	4
R132-124-000	mm	124	244	100
	<i>inch</i>	4.9	9.6	4
R132-160-000	mm	164	164	100
	<i>inch</i>	6.5	6.6	4
R132-162-000	mm	164	244	100
	<i>inch</i>	6.5	9.6	4
R132-164-000	mm	164	324	100
	<i>inch</i>	6.5	13	4
R132-400-000	mm	404	404	160
	<i>inch</i>	15.9	15.9	6.3

Non-Metallic

polyDOOR - Polyester

Specifications



Standards

- NEMA Type 1, 2, 3, 3R, 4, 4X, 5, 12 and 13
- IEC 60529, IP66
- VO Flammability Rating
- CSA certified, Type 4, for use with industrial control equipment



Construction

- Two piece molded fiberglass reinforced polyester construction.
- Captive polyfibre cover screws are provided with a standard slot head.
- Cover screws fasten into pre-threaded holes.
- The threaded cover screw holes also provide single channel access to rear mounting positions.
- Recessed neoprene gasket with tongue and groove construction is oil and petroleum resistant.
- Threaded stainless steel inserts provide for internal mounting.

Finish

- Light beige RAL 7032, Pantone 413
- Spring loaded stainless steel hinge pins are standard, allowing for quick lid removal . (R130 & R131 Series only)

Application

- Designed for use as instrument enclosures, electrical junction boxes or terminal wiring enclosures.
- Provide outstanding protection against dust, oil and pressurized water.
- Impervious to atmospheric and marine corrosion.

Non-Metallic

1 Captive screws made of strong polyamide, corrosion free...

2 Oil resistant CR gasket...

3 Easily removable stainless steel hinge pin...

4 Four stainless steel M6 inserts in bottom of enclosure (screws not included)...

5 Single channel for lid screws and enclosure mounting, which allows for maximum internal space. This channel is outside of the gasket seal area, and includes stainless steel inserts.

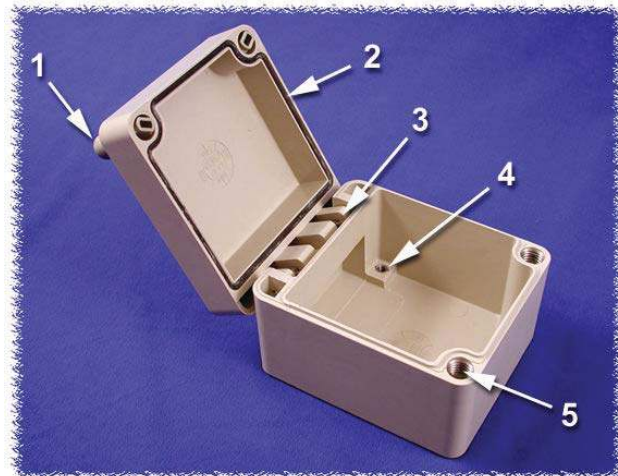

polyDOOR - Polyester

R130, R131 Series

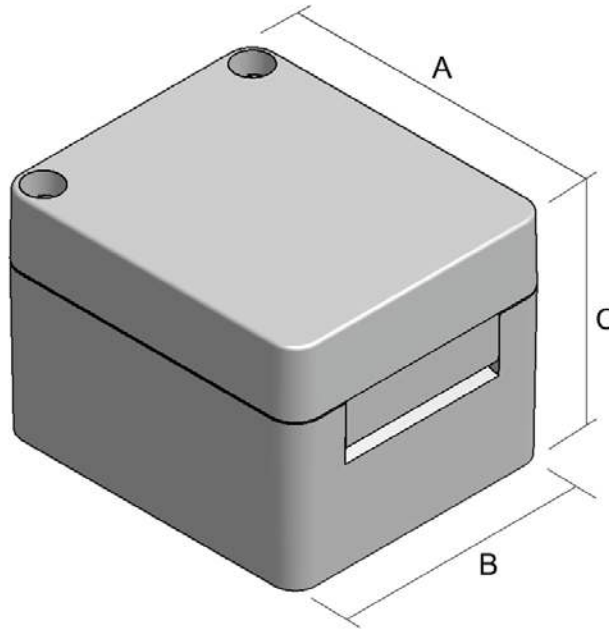

Non-Metallic

With Integrated Hinge

Part No.	Units	Width A	Length B	Depth (Including Lid) C
R130-120-000	mm	120	140	100
	<i>inch</i>	4.8	5.6	4
R130-122-000	mm	120	200	100
	<i>inch</i>	4.8	8	4
R130-124-000	mm	120	260	100
	<i>inch</i>	4.8	10.4	4
R130-160-000	mm	160	180	100
	<i>inch</i>	6.4	7.2	4
R130-162-000	mm	160	260	100
	<i>inch</i>	6.4	10.4	4
R130-164-000	mm	160	340	100
	<i>inch</i>	6.4	13.6	4
R130-200-000	mm	200	220	120
	<i>inch</i>	8	8.8	4.8
R130-202-000	mm	200	320	120
	<i>inch</i>	8	12.8	4.8

With Integrated Hinge & Acrylic Window in Lid

Part No.	Units	Width A	Length B	Depth (Including Lid) C
R131-120-000	mm	120	140	100
	<i>inch</i>	4.8	5.6	4
R131-122-000	mm	120	200	100
	<i>inch</i>	4.8	8	4
R131-124-000	mm	120	260	100
	<i>inch</i>	4.8	10.4	4
R131-160-000	mm	160	180	100
	<i>inch</i>	6.4	7.2	4
R131-162-000	mm	160	260	100
	<i>inch</i>	6.4	10.4	4
R131-164-000	mm	160	340	100
	<i>inch</i>	6.4	13.6	4
R131-200-000	mm	200	220	120
	<i>inch</i>	8	8.8	4.8
R131-202-000	mm	200	320	120
	<i>inch</i>	8	12.8	4.8

Additional Rolec Literature



ROLEC Full Line Catalog
English / German
(Available upon request)



ROLEC Ex-Enclosure Catalog
English / German
(Available upon request)

Rolec on the Web

For complete technical information, or inquiries outside of North America, please visit:

www.rolec.de



Factory Modified Enclosures



- Machining
- Silk Screening
- Hot Stamping
- Special Colors
- Custom Materials

Easy to quote and order

- Mark up our PDF drawings downloadable from our website
- Modify our AutoCad files downloadable from our website
- Email us at modifieds@hammondmfg.com

Certifications

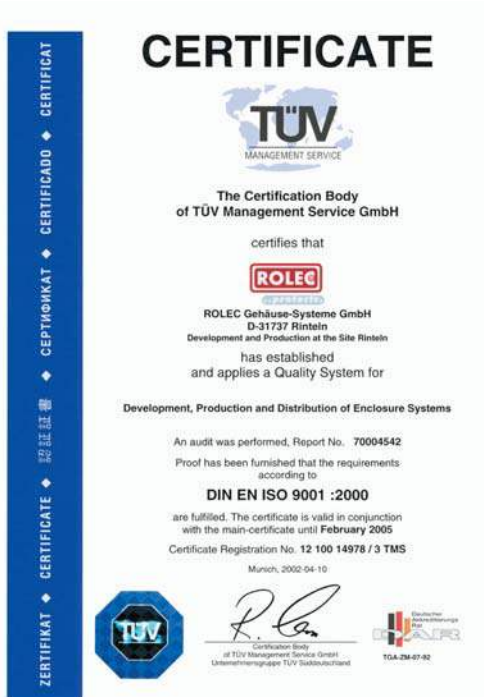

Applies to aluNORM, conFORM, polyTOP, and polyDOOR Series

Degree of protection - "IP" Codes Information

Example:

IP 55

I.P. Protection Classification		
Degrees of contact prevention and guarding against foreign objects		
1st I.P. Digit	Designation	Explanation
0	No protection	No protection of personnel from direct contact with active or moving parts. No protection from access of solid foreign object.
1	Protection against large foreign bodies	Protection of personnel from accidental large area direct contact with active or internal moving parts (hand contact etc.) but no guard against intentional access to such parts. Protection from access of solid foreign object larger than 12 mm in diameter.
2	Protection against medium foreign bodies	Protection of personnel from finger contact with active or internal moving parts. Protection from access of solid foreign object larger than 12 mm in diameter.
3	Protection against small foreign bodies	Protection of personnel from touching active or internal moving parts with tools, wires or similar foreign objects thicker than 2.5 mm. Protection from access of solid foreign matter larger than 2.5 mm in diameter.
4	Protection against granular foreign bodies	Protection of personnel from touching active or internal moving parts with tools, wires or similar foreign objects thicker than 1 mm.
5	Protection from deposit of dust	Total protection of personnel from touching voltage carrying or internal moving parts. Protection from harmful deposit of dust. Access of dust is not completely prevented.
6	Protection from access of dust	Total protection of personnel from touching voltage carrying or internal moving parts. Protection from access of dust.

I.P. Protection Classification		
Degrees of water protection		
2nd I.P. Digit	Designation	Explanation
0	No protection	No special protection
1	Protection against water dripping vertically	Water drops falling vertically must not have any harmful effect.
2	Protection against water dripping off vertically	Water drops falling at any angle up to 15° from the vertical must not have any harmful effect.
3	Protection against spray water	Water drops falling at any angle up to 15° from the vertical must not have any harmful effect.
4	Protection against splash water	Water splashing against the object from all directions must not have any harmful effect.
5	Protection against jet water	A jet of water nozzled from all directions must not have any harmful effect.
6	Protection against flooding	Water from temporary flooding, such as heavy seas, must not enter in any harmful quantity.
7	Protection in dipped state	If the object is dipped into water under the defined conditions of pressure and time, water must not enter it in any harmful quantity.
8	Protection in submerged state	If the object is submerged in water, water must not enter in any harmful quantity.

Additional Hammond Literature



Catalog
9R

Electronic
Racks

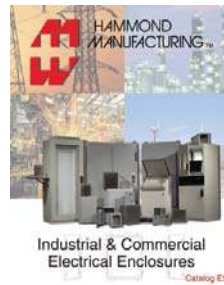

Catalog
E5

Industrial Electrical
Enclosures



Catalog
PB

Power Outlet
Strips

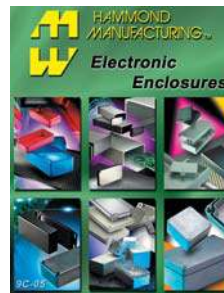

Catalog
9C

Electronic
Enclosures

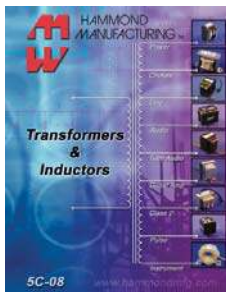

Catalog
5C

Electronic
Transformers



Catalog
9C-R1

Ritec
Enclosures

Hammond on the Web

For detailed drawings, CAD files, catalog requests and downloads please visit Hammond's website at:

www.hammondmfg.com

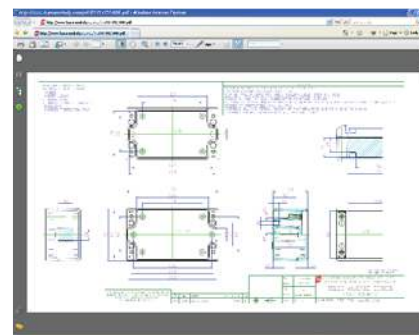

Technical references and CAD downloads available at www.hammondmfg.com



HAMMOND MANUFACTURING™



USA

Hammond Mfg. Co. Inc.
475 Cayuga Road
Cheektowaga, NY 14225
Tel: (716) 630-7030
Fax: (716) 630-7042

Canada

Hammond Mfg. Co. Ltd.
394 Edinburgh Road North
Guelph, Ontario N1H 1E5
Tel: (519) 822-2960
Fax: (519) 822-0715

Les Fabrications Hammond
(Quebec) Inc.
4240 Seré Street
St. Laurent, Quebec H4T 1A6
Tel: (514) 343-9010
Fax: (514) 343-9941

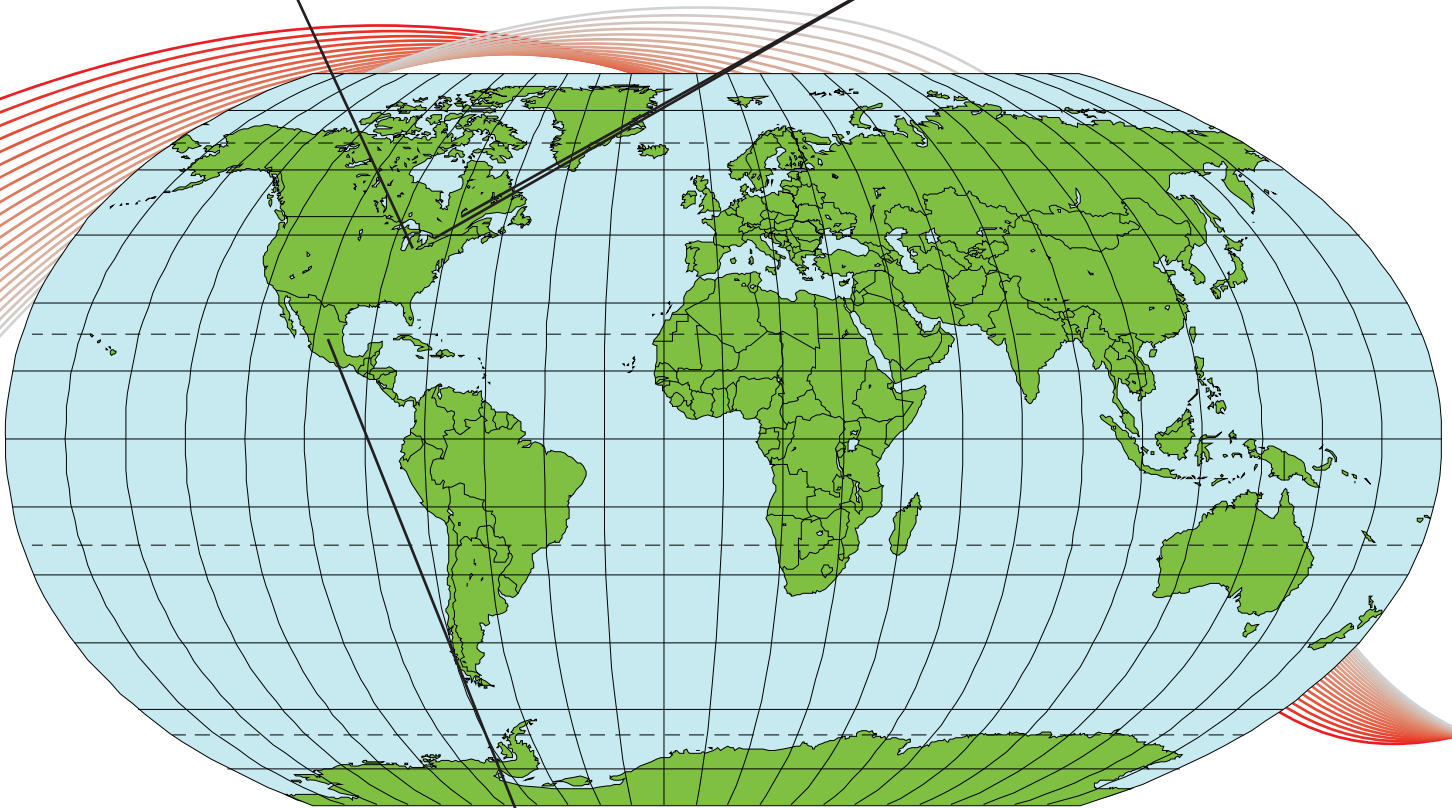

Mexico

Hammond Mfg. Co. Inc.
475 Cayuga Road
Cheektowaga, NY 14225
Tel: +1 716 630 7030
Fax: +1 716 630 7042

www.hammondmfg.com