

ZXFV202N8EV

SINGLE CHANNEL VIDEO AMPLIFIER EVALUATION BOARD

Evaluation board description

The wide bandwidth of the ZXFV202 video amplifier necessitates some care in the layout of the printed circuit. For this reason Zetex has made available an Evaluation Board.

The Evaluation Board layout serves as a useful example for many applications, showing a practical implementation of the advice given below.

Figures 1, 2 and 3 show the schematic and copper layout of a double-sided printed circuit board suitable for evaluation of the device in the laboratory.

BNC connector sockets allow connection to test instruments via 50Ω cables. The output circuit includes a resistor matching circuit to present a load of 150Ω to the amplifier (equivalent to a 75Ω back-terminated video line) and simultaneously provide 50Ω output impedance.

The attenuation of this matching circuit is 15.45 dB. As the amplifier is configured for a voltage gain of 2, the overall gain is:

$$6 - 15.45 = -9.45\text{dB.}$$

PCB design

A continuous ground plane is required under the device and its signal connection paths, to provide the shortest possible ground return paths for signals and power supply filtering.

A double-sided or multi-layer PCB construction is required, with plated-through via holes providing closely spaced low-inductance connections from some components to the continuous ground plane (some of these holes are not visible in the figures for the Evaluation Board –artworks and NC drill output can be provided if required).

Power supply filtering

For the power supply filtering, low inductance surface mount capacitors are normally required. It has been found that very good RF decoupling is provided on each supply using a 1000pF NPO size 0805 or smaller ceramic surface mount capacitor, closest to the device pin, with an adjacent 0.1μF X7R capacitor. Other configurations are possible and it may be found that a single 0.01μF X7R capacitor on each supply gives good results. However this should be supported by larger decoupling capacitors elsewhere on the printed circuit board. Values of 1 to 10 μF are recommended, particularly where the voltage regulators are located more than a few inches from the device. These larger capacitors are recommended to be solid tantalum electrolytic or ceramic types.

A parts list is provided on the next page.

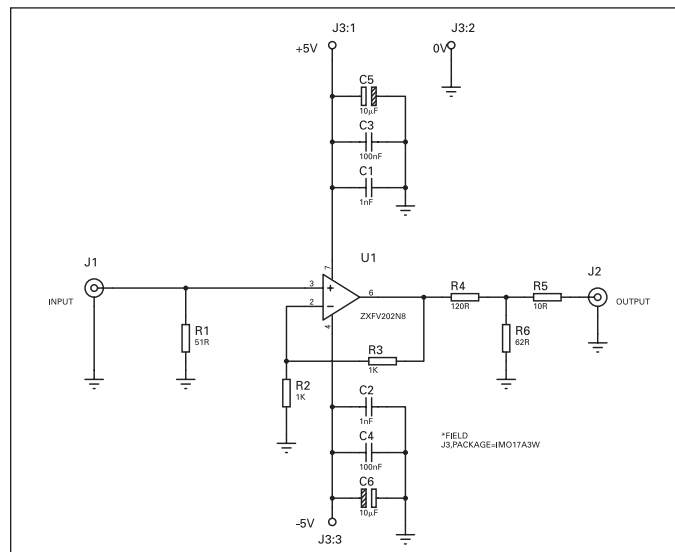

Figure 1 Circuit schematic

ZXFV202N8EV

Evaluation Board Parts List:

QTY	CCT-REF	VALUE	DESCRIPTION
Resistors, surface mount			
1	R1,	51R	0805
2	R2,R3	1k	0805
1	R4	120R	0805
1	R5	10R	0805
1	R6	62R	0805
Capacitors, surface mount			
2	C1,C2	1nF	25V ceramic 0805 X7R
2	C3,C4	100nF	50V ceramic 0805 NPO
2	C5,C6	10 F	16V Tant Elec size C
Integrated circuits			
1	U1	"	Zetex ZXFV202N8
Miscellaneous			
2	J1,J2	"	BNC Socket, PCB straight flange, e.g. Tyco B35N14H999X99
1	J3	"	3-way PCB screw terminal block IMO 20.501/3SB

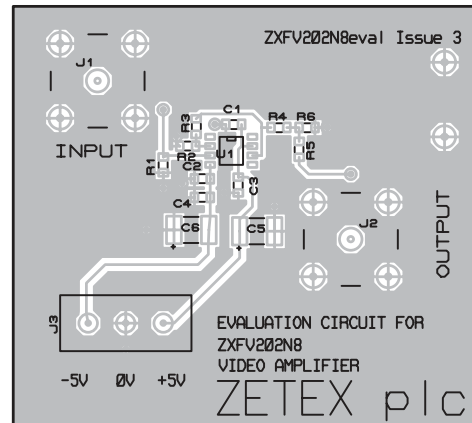

Figure 2 Evaluation circuit top copper layout (overall dimensions 2.5 x 2.25 inches)

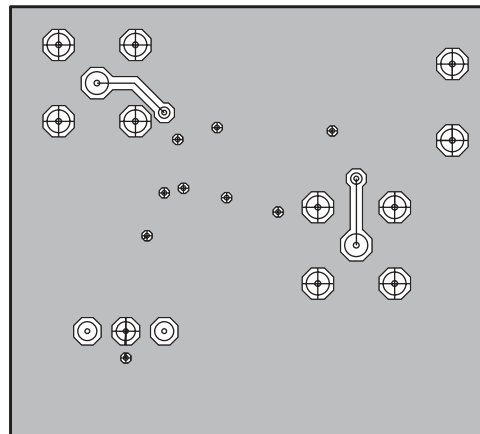

Figure 3 Evaluation board bottom copper layout (viewed through from top) (overall dimensions 2.5 x 2.25 inches)

© Zetex Semiconductors plc 2004

Europe	Americas	Asia Pacific	Corporate Headquarters
Zetex GmbH Streitfeldstraße 19 D-81673 München Germany	Zetex Inc 700 Veterans Memorial Hwy Hauppauge, NY 11788 USA	Zetex (Asia) Ltd 3701-04 Metroplaza Tower 1 Hing Fong Road, Kwai Fong Hong Kong	Zetex plc Lansdowne Road, Chadderton Oldham, OL9 9TY United Kingdom
Telefon: (49) 89 45 49 49 0 Fax: (49) 89 45 49 49 49 europa.sales@zetex.com	Telephone: (1) 631 360 2222 Fax: (1) 631 360 8222 usa.sales@zetex.com	Telephone: (852) 26100 611 Fax: (852) 24250 494 asia.sales@zetex.com	Telephone (44) 161 622 4444 Fax: (44) 161 622 4446 hq@zetex.com

These offices are supported by agents and distributors in major countries world-wide.

This publication is issued to provide outline information only which (unless agreed by the Company in writing) may not be used, applied or reproduced for any purpose or form part of any order or contract or be regarded as a representation relating to the products or services concerned. The Company reserves the right to alter without notice the specification, design, price or conditions of supply of any product or service.

For the latest product information, log on to www.zetex.com.



ISSUE 1 - MAY 2004