

- NOTES:
- MATERIALS AND FINISHES:
 BODY - ZINC ALLOY, MATTE TIN PLATING
 CONTACT - BRASS, GOLD PLATING
 COVER - BRASS, MATTE TIN PLATING
 FRONT INSULATOR - PTFE
 REAR INSULATOR - PBT
 - ELECTRICAL:
 A. IMPEDANCE: 50 OHM
 B. FREQUENCY RANGE: DC - 1.0 GHz
 C. VSWR(RETURN LOSS): 1.4 (16 dB), MAX.
 D. DIELECTRIC WITHSTANDING VOLTAGE: 1500 VRMS, MIN.
 - MECHANICAL:
 A. DURABILITY: 100 CYCLES MIN.
 B. TEMPERATURE RANGE: -65° C TO 165° C
 - PACKAGE PER SPEC 349-50900. KEY ELEMENTS INCLUDE:
 A. UNIT-BOX LABEL CAN NOT CONTAIN ANY REFERENCES TO MOTOROLA OR MOTOROLA SOLUTIONS BRAND NAME, LOGOS, IMAGES OR GRAPHICS.
 B. ESD SENSITIVE COMPONENTS MUST BE PACKAGED PER ANSI/ESD S 541, IN CLEAN, NON-CORROSIVE MATERIALS WITH PROTECTIVE ELECTRICAL PROPERTIES, AND IDENTIFIED WITH ESD CAUTIONARY LABELS.
 C. ALL BOX FILLING MATERIAL TO FILL EMPTY SPACE IN CARTONS MUST BE ROHS 2002 COMPLIANT.
 D. PACKAGING MUST BE MARKED WITH APPLICABLE RECYCLING LOGOS. PLASTICS MUST BE MARKED WITH APPROPRIATE MATERIAL DESIGNATION.
 E. WEIGHT OF CONTAINER, FILLED WITH PRODUCT AND ALL INTERIM PROCESS CONTAINERS, SHALL NOT EXCEED 40 LBS.
 F. SHIPPING BOXES MUST BE PRINTED WITH BOX CERTIFICATE AND PACKING LIST WITH BAR CODES FOR PO. QTY, SYMBOL PART NUMBER, & COUNTRY OF ORIGIN.
 G. TAPE MUST BE USED FOR CLOSING THE PACKAGES. SINGLE AND DOUBLE COVER BOXES SHOULD BE BANDED AND NOT TAPED.

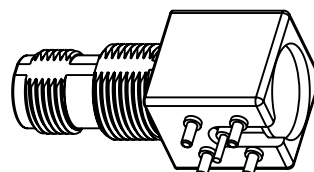

SCALE 1.000

THIRD ANGLE PROJ.

REVISIONS				
REV	DESCRIPTION	DATE	ECO	APPR
A	RELEASE TO MFG.	27-Jun-05	45603	HP
E	SYNC ARFA AND DANBURY DRAWING; BODY, INSULATOR AND CENTER PIN CHANGE WITH REAL NUMBER	12-Jul-11	48621	D.H.
F	MODIFY NOTE 1 REAR INSULATOR MATERIAL SPEC. \RD-DMI3062701S2	09-Jul-13	49621	HARRY
G	UPDATED PACKAGING NOTE TO REFLECT SPEC 349-50900 RD-DMI5051201R3	21-May-15	50489	RM

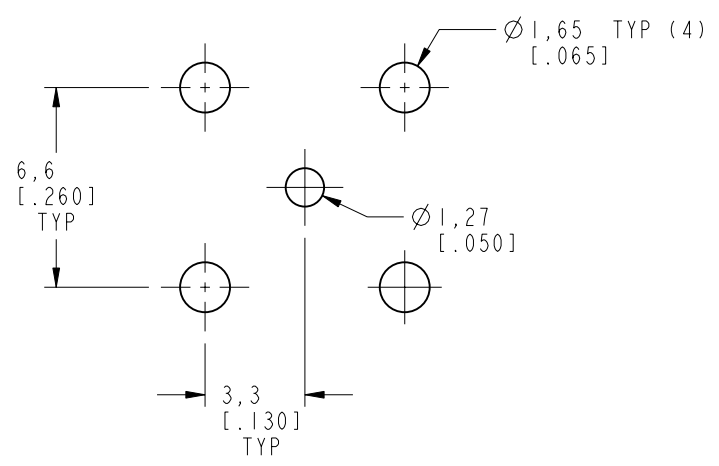
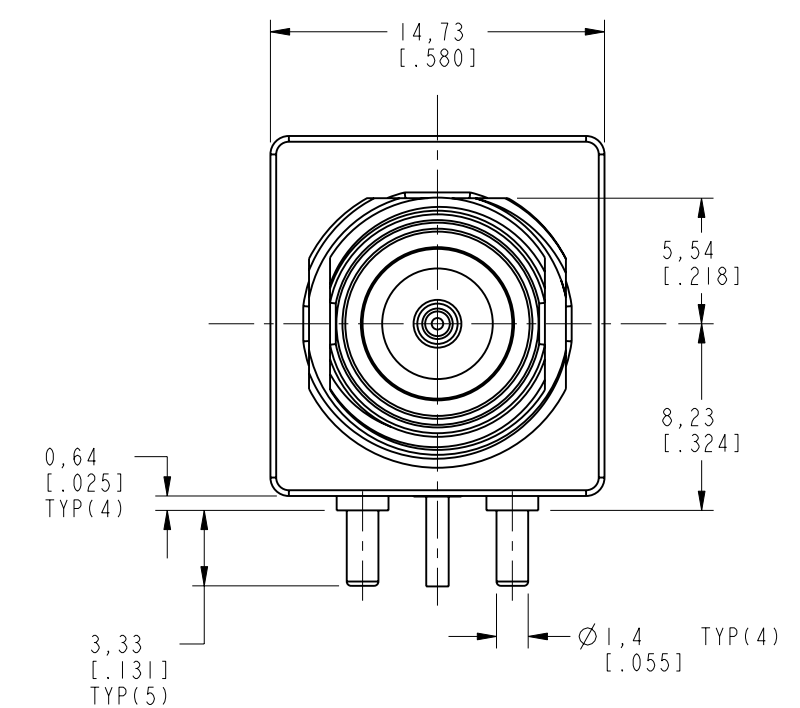
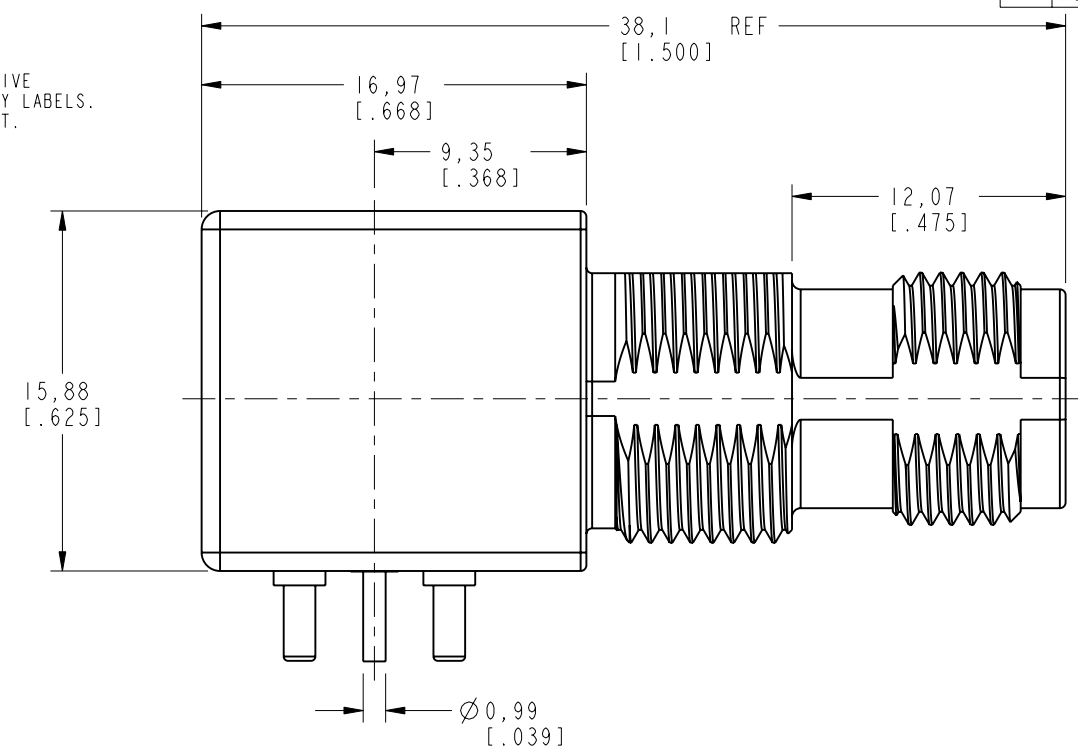

RECOMMENDED PCB MOUNTING DIMENSIONS

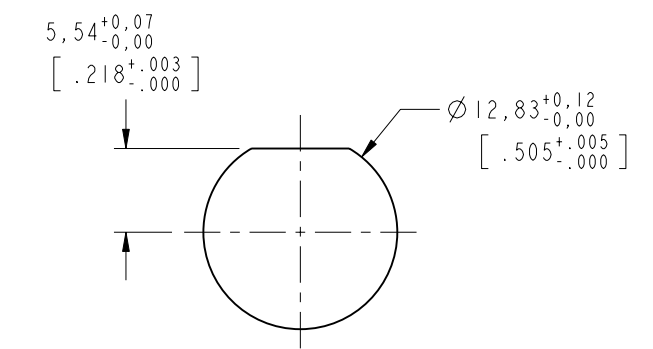
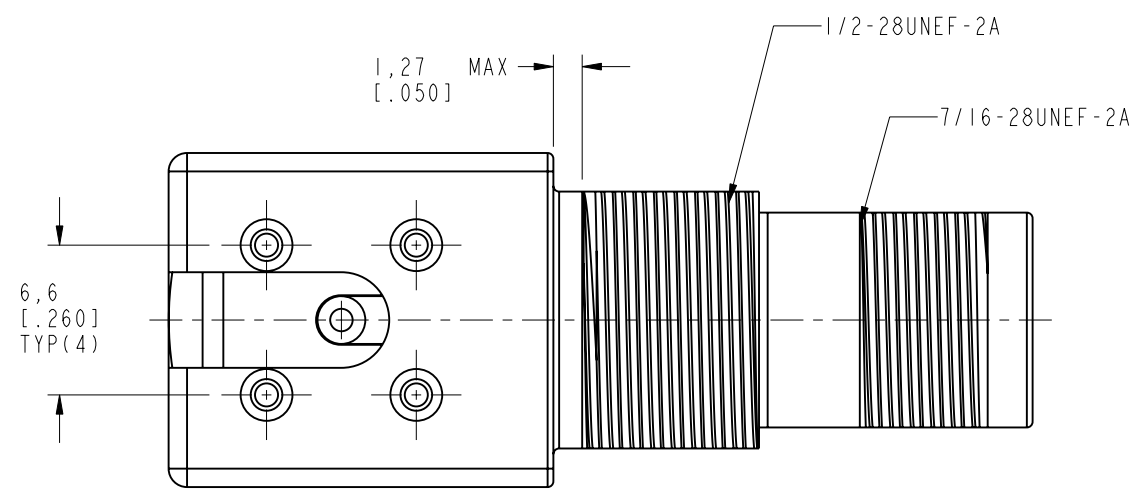

RECOMMENDED PANEL MOUNTING HOLE

CUSTOMER OUTLINE DRAWING
 ALL OTHER SHEETS ARE FOR INTERNAL USE ONLY

UNLESS OTHERWISE SPECIFIED, DIMENSIONS ARE IN METRIC AND TOLERANCES ARE: <0.5mm ±0.05mm 0.5 - 6mm ±0.1mm 6 - 30mm ±0.2mm 30 - 120mm ±0.3mm ANGLES ±1°	MATERIAL SEE NOTE	DRAWN S. DUAN	DATE 02-Jul-13	TITLE TNC (RP) R/A PCB BULKHEAD BODY TIN PLATED	Amphenol RF www.amphenolrf.com
	REFERENCE 1608 AND 611X-4199-100	ENGINEER H. PARIKH	DATE 21-Jun-05		
	CONFIGURATION LEVEL: In Work	APPROVED S. HSIEH	DATE 21-May-15	ITEM NO. 31-6240-3	
	FINISH	CAD FILE	SCALE: 3.0:1.0	SHEET 2 OF 2	PART NO. 31-6240-3