

REVISIONS					
P	LTR	DESCRIPTION	DATE	DWN	APVD
K3		REV. ECO 17-011267	05SEP2017	HC	KR

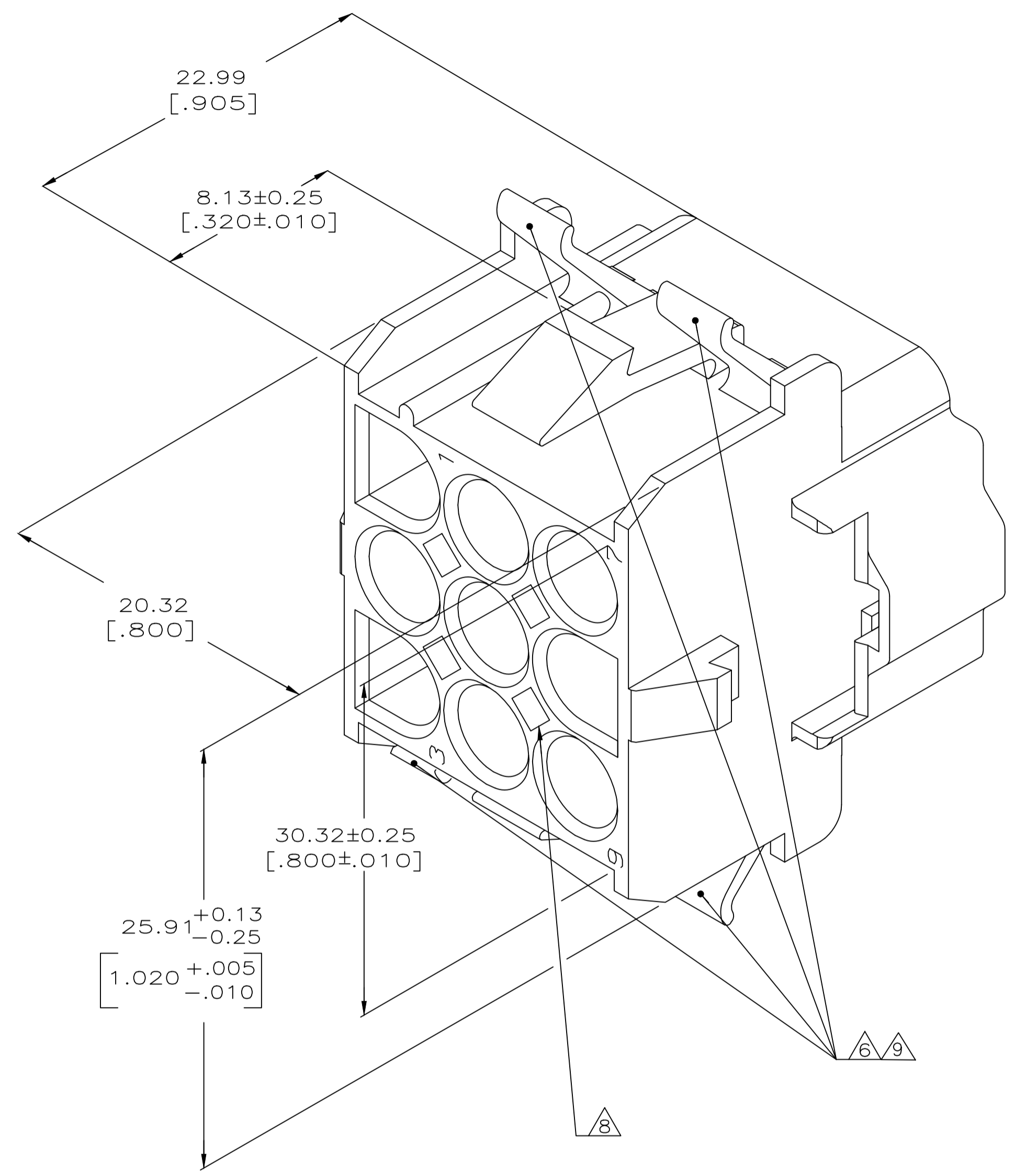

- MUST BE ASSEMBLED WITH CAP REAR P/N 770054-1 BEFORE MATING. KIT P/N IS 770028-1.
- RECOMMENDED PANEL THICKNESS 0.76-2.29 [.030-.090].
- PANEL MUST BE PUNCHED SO THAT THE HOUSING ENTERS THE PANEL IN THE SAME DIRECTION AS THE PUNCH.
- OPTIONAL FOR KEYING HOUSING IN PANEL.
- CIRCUIT NUMBER 1 LOCATION.
- AMP LOGO LOCATED ONCE ON ANY INDICATED SURFACE FARSIDE.
- DIMENSIONS SHOWN REPRESENT PRODUCT IN DRY, AS MOLDED, CONDITION. ADDITIONAL 2% GROWTH DUE TO SUBSEQUENT MOISTURE ABSORPTION MAY OCCUR AND SHOULD BE ACCOUNTED FOR.
- OPTIONAL CONSTRUCTION PROVIDES ROUND MATERIAL REDUCTION CORING HOLES.
- CSA LOGO LOCATED ONCE ON ANY INDICATED SURFACE

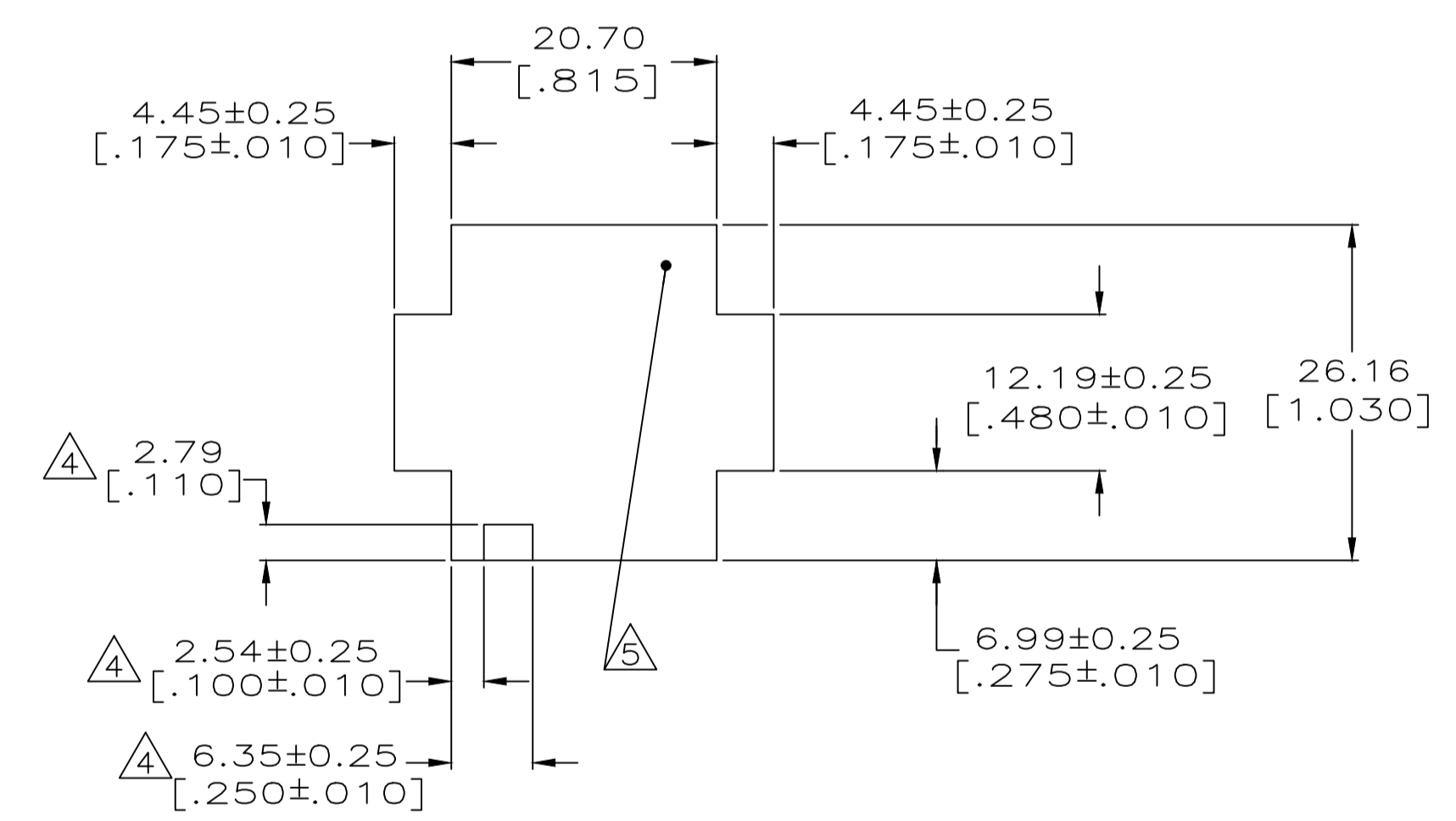

RECOMMENDED PANEL CUTOUT
(HOUSING ENTRY SIDE)
SCALE 2:1
② ③

770053-1
PART NUMBER

THIS DRAWING IS A CONTROLLED DOCUMENT.		DRW K SALMON 1-15-92	TE Connectivity	
DIMENSIONS: INCHES		CHK R SWING 1-15-92	NAME CAP FRONT, 9 CIRCUIT, UNIVERSAL MATE-N-LOK	
TOLERANCES UNLESS OTHERWISE SPECIFIED:		APVD	PRODUCT SPEC	
0 PLC ± -		APVD	APPLICATION SPEC	
1 PLC ± -		APVD	RESTRICTED TO	
2 PLC ± -		APVD	SIZE CAGE CODE DRAWING NO	
3 PLC ± 0.13 [.005]		APVD	A1 00779 C=770053	
4 PLC ± - ± -		APVD	WEIGHT 0.000000	
ANGLES ± - ± -		APVD	CUSTOMER DRAWING	
MATERIAL NYLON,UL94V-0, FINISH -		APVD	SCALE 5:1 SHEET 0 OF 0 REV K3	