

4

3

2

1

THIS DRAWING IS UNPUBLISHED. RELEASED FOR PUBLICATION - , - .
 © COPYRIGHT - By - ALL RIGHTS RESERVED.

| | | | | | | | |
|-----|------|-----------|-----|---------------------------|---------|-----|------|
| LOC | DIST | REVISIONS | | | | | |
| AG | 53 | P | LTR | DESCRIPTION | DATE | DWN | APVD |
| | | | C1 | REVISED PER ECO-11-004835 | 11MAR11 | RK | HMR |

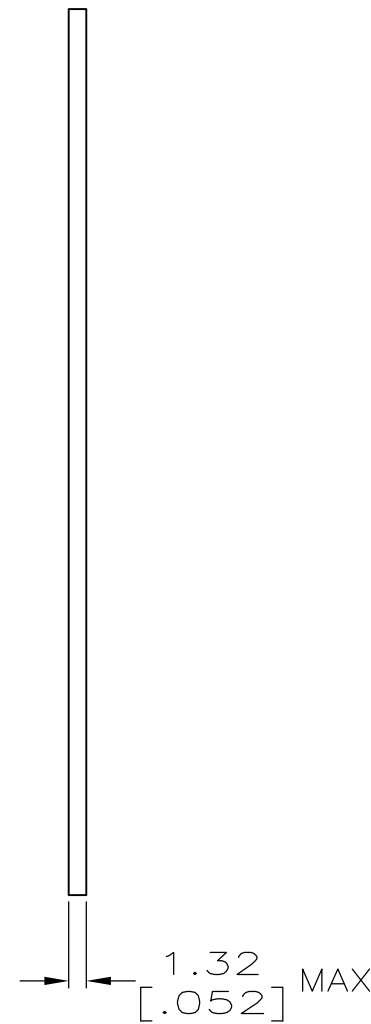
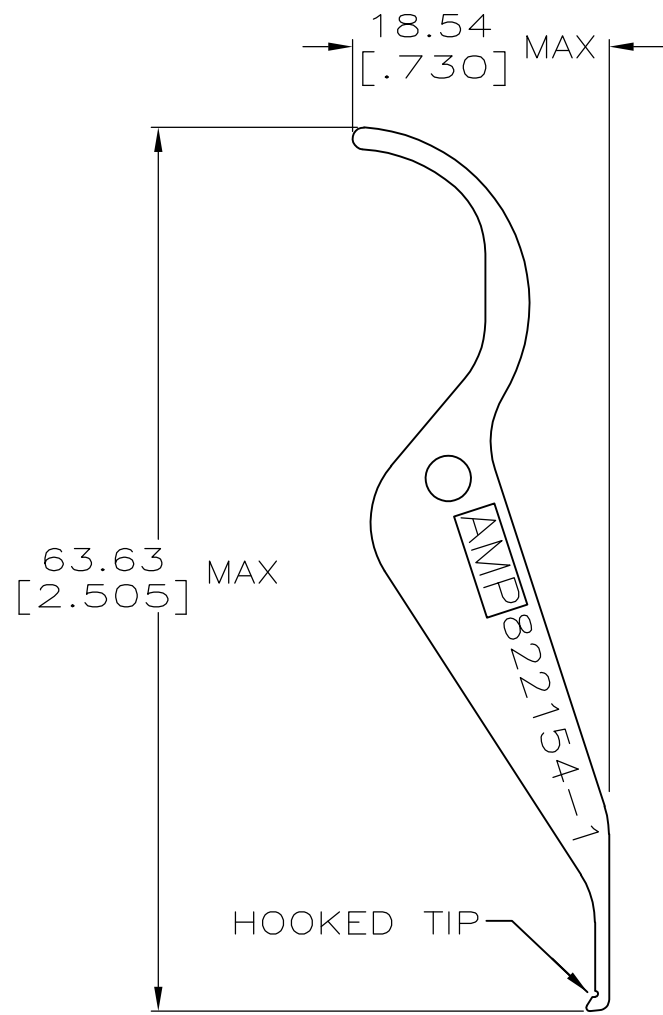

| | | | | | | | | |
|---|--|---|----------|---------|------------------------------|-----------|------------|---------------|
| THIS DRAWING IS A CONTROLLED DOCUMENT. | | DWN | R.TALLEY | 3-8-91 | STE TE Connectivity | | | |
| DIMENSIONS: mm[INCHES] | | CHK | R.MILLER | 3-28-91 | | | | |
| | | TOLERANCES UNLESS OTHERWISE SPECIFIED: | | | NAME | | | |
| | | 0 PLC ± - 1 PLC ± - 2 PLC ± - 3 PLC ± - 4 PLC ± - ANGLES ± - | | | K.KREIDLER 3-28-91 | | | |
| MATERIAL | | PRODUCT SPEC | | | CHIP CARRIER EXTRACTION TOOL | | | |
| STAINLESS STEEL | | FINISH | | | APPLICATION SPEC | | | |
| THIS DRAWING IS A CONTROLLED DOCUMENT FOR AMP INCORPORATED. IT IS SUBJECT TO CHANGE AND THE CONTROLLING ENGINEERING ORGANIZATION SHOULD BE CONTACTED FOR THE LATEST REVISION. | | WEIGHT | | | SIZE | CAGE CODE | DRAWING NO | RESTRICTED TO |
| | | - | | | A3 | 00779 | C-822154 | - |
| CUSTOMER DRAWING | | | | | SCALE | SHEET | REV | |
| | | | | | 2:1 | 1 of 1 | C1 | |