

NHD-C12864A1Z-FSR-FBW-HTT

COG (Chip-On-Glass) Liquid Crystal Display Module

NHD- Newhaven Display
C12864- 128 x 64 Pixels
A1Z- Model
F- Transflective
SR- Side Red LED Backlight
F- FSTN Positive
B- 6:00 Optimal View
W- Wide Temp
HTT- With 12V Heater (-40°C to +70°C)
RoHS Compliant

Newhaven Display International, Inc.

2661 Galvin Ct.

Elgin IL, 60124

Ph: 847-844-8795

Fax: 847-844-8796

www.newhavendisplay.com

nhtech@newhavendisplay.com

nhsales@newhavendisplay.com

Document Revision History

Revision	Date	Description	Changed by
0	10/20/10	Initial Release	-
1	10/26/10	Pin Length Adjusted from 0.5" to 0.3" on Mechanical drawing.	MC
2	10/27/10	Supply Current and block diagram updated	BE
3	1/20/11	Operating Temp updated	BE
4	8-31-11	Electrical characteristics updated	AK
5	7/30/12	Electrical characteristics updated	AK
6	8/31/15	Electrical characteristics, Mechanical drawing updated	SB
7	6/4/19	Added PCB Footprint Drawing	AS
8	1/31/20	Glass Panel Updated	SB
9	7/16/20	Updated Serial Interface Timing Characteristics	AS
10	11/16/20	Updated LCD Contrast Range from 8.5V/8.7V/8.9V to 8.8V/9.0V/9.2V Part Revision Upgraded to Rev1B	AS
11	3/26/21	Updated Supply Voltage Range	AS
12	4/8/21	Updated the Electrical, Optical Characteristics, Table of Commands, Quality Information and Mechanical Drawing	JT

Functions and Features

- 128 x 64 pixels
- Built-in ST7565P controller
- +3.0V power supply
- 1/65 duty cycle; 1/9 bias
- Built-in Heater
- RoHS Compliant

Mechanical Drawing

SYMBOL	REVISION	DATE

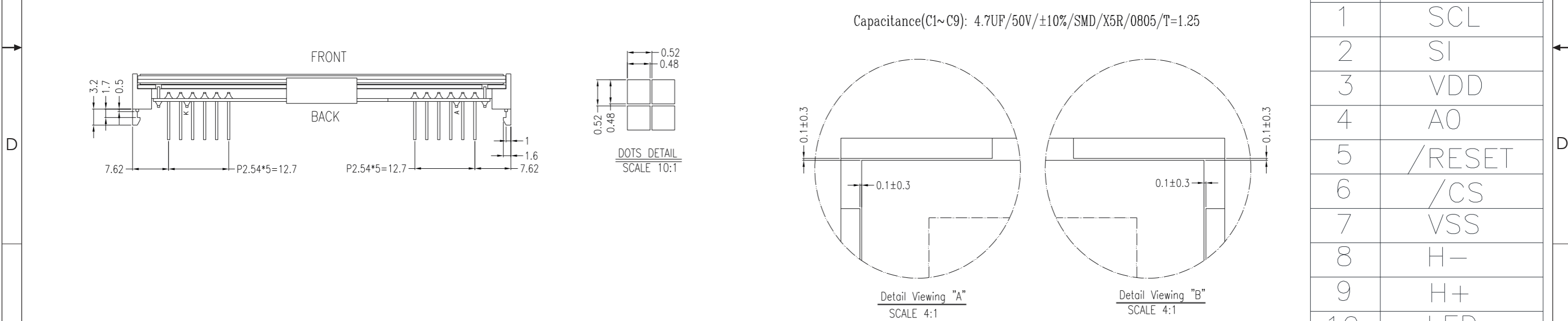
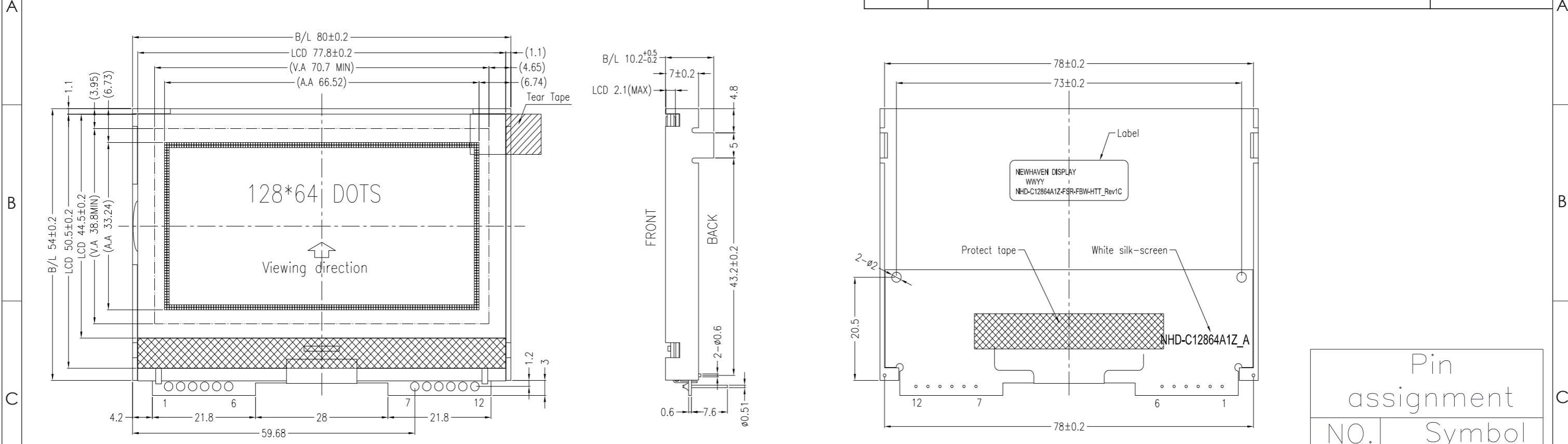

Notes:

- Driving: 1/65 duty, 1/9 bias
- Voltage: 3.0V V_{DD}, 9.0V V_{LCD}
- Display Type: FSTN Positive / Transflective
- Optimal View: 6:00
- Backlight: Red Edge light LED`
- Driver IC: ST7565P 2-Line SPI Interface
- Built-in Heater

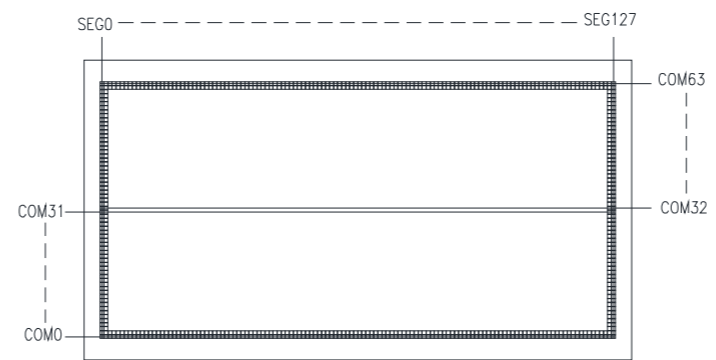

STANDARD TOLERANCE: (UNLESS OTHERWISE SPECIFIED)

LINEAR: ±0.3mm

UNLESS OTHERWISE SPECIFIED:
 - DIMENSIONS ARE IN MILLIMETERS
 - THIRD ANGLE PROJECTION

DO NOT SCALE DRAWING

NEWHAVEN DISPLAY INTERNATIONAL
 DRAWING/PART NUMBER: NHD-C12864A1Z-FSR-FBW-HTT
 REVISION: 1C
 SIZE: A3
 SCALE: NS
 SHEET 1 OF 1

DRAWN BY: J.Thomas
 APPROVED BY: J.Thomas
 DRAWN DATE: 4/8/21
 APPROVED DATE: 4/8/21

THIS DRAWING IS SOLELY THE PROPERTY OF NEWHAVEN DISPLAY INTERNATIONAL, INC. THE INFORMATION IT CONTAINS IS NOT TO BE DISCLOSED, REPRODUCED OR COPIED IN WHOLE OR PART WITHOUT WRITTEN APPROVAL FROM NEWHAVEN DISPLAY.

Recommended PCB Footprint

SYMBOL	REVISION	DATE

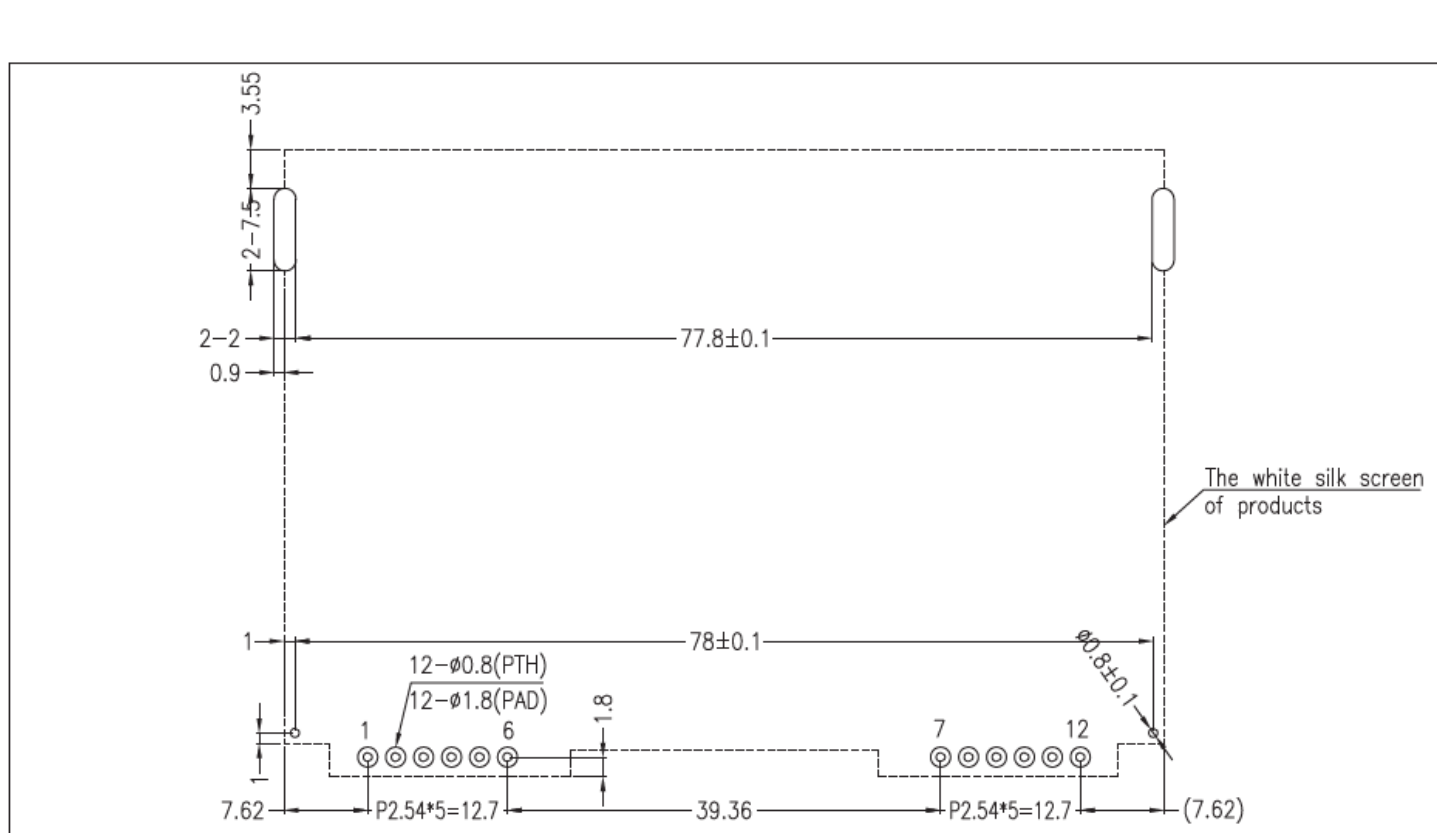

- Applicable Displays:**
- 1) NHD-C12864A1Z-FSW-FBW-HTT
 - 2) NHD-C12864A1Z-FSR-FBW-HTT
 - 3) NHD-C12864A1Z-FSB-FBW-HTT

STANDARD TOLERANCE: UNLESS OTHERWISE SPECIFIED		NEWHAVEN DISPLAY INTERNATIONAL	
LINEAR: ±0.3mm		DRAWING/PART NUMBER: NHD-C12864A1Z-Monochrome-Footprint	REVISION: 1.0
UNLESS OTHERWISE SPECIFIED: - DIMENSIONS ARE IN MILLIMETERS - THIRD ANGLE PROJECTION		DRAWN BY: A. Shah	APPROVED BY: A. Khan
		DRAWN DATE: 6/3/19	APPROVED DATE: 6/3/19
		DO NOT SCALE DRAWING	
		SHEET 1 OF 1	
THIS DRAWING IS SOLELY THE PROPERTY OF NEWHAVEN DISPLAY INTERNATIONAL, INC. THE INFORMATION IT CONTAINS IS NOT TO BE DISCLOSED, REPRODUCED OR COPIED IN WHOLE OR PART WITHOUT WRITTEN APPROVAL FROM NEWHAVEN DISPLAY.			

Pin Description and Wiring Diagram

Pin No.	Symbol	External Connection	Function Description
1	SCL	MPU	Serial Clock Input
2	SI	MPU	Serial Data Input
3	V _{DD}	Power Supply	Supply Voltage for LCD and Logic (+3.0V)
4	A0	MPU	Register Select. 0: instruction; 1: data
5	/RESET	MPU	Operation Active LOW Reset signal
6	/CS	MPU	Active LOW Chip Select Signal
7	V _{SS}	Power Supply	Ground
8	H-	Power Supply	Ground for Heater
9	H+	Power Supply	Power for Heater (+12V)
10	LED-	Power Supply	Backlight Cathode (Ground)
11	LED+	Power Supply	Backlight Anode (+3.3V)
12	NC	-	No Connect

Recommended LCD connector: 2.54mm pitch thru-hole connection on PCB

Backlight connector: --- Mates with: ---

Recommended Breakout Board: [NHD-PCB40](#)

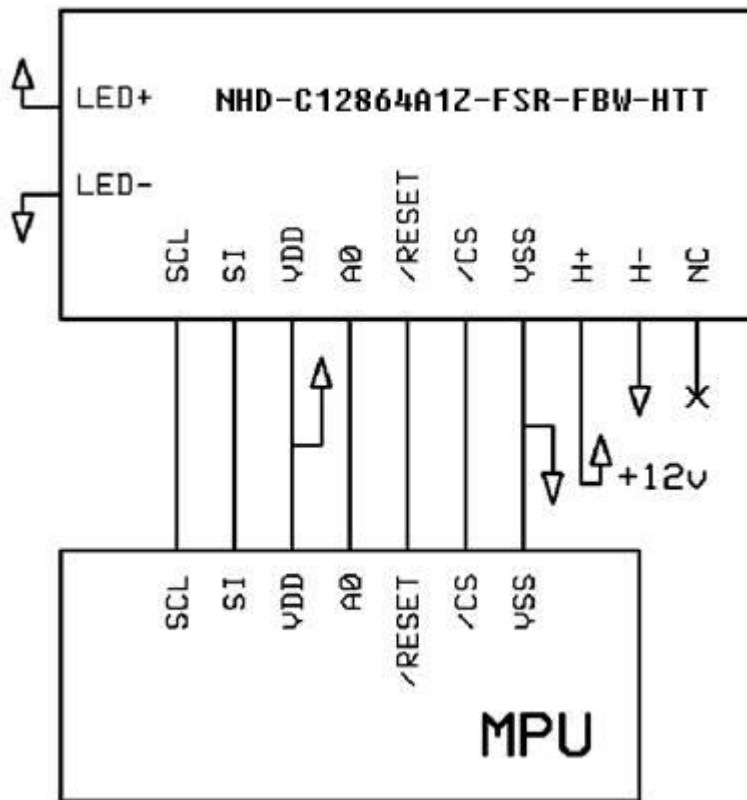

Electrical Characteristics

Item	Symbol	Condition	Min.	Typ.	Max.	Unit
Operating Temperature Range	T _{OP}	Absolute Max	-40	-	+70	°C
Storage Temperature Range	T _{ST}	Absolute Max	-30	-	+80	°C
Supply Voltage	V _{DD}	-	2.8	3.0	3.2	V
Supply Current	I _{DD}	T _{OP} =25°C	0.1	0.2	1.0	mA
Supply for LCD (contrast)	V _{DD} -V ₀	V _{DD} =3.0V	8.8	9.0	9.2	V
"H" Level input	V _{IH}	-	0.8 * V _{DD}	-	V _{DD}	V
"L" Level input	V _{IH}	-	V _{SS}	-	0.2 * V _{DD}	V
"H" Level output	V _{OH}	-	0.8 * V _{DD}	-	V _{DD}	V
"L" Level output	V _{OL}	-	V _{SS}	-	0.2 * V _{DD}	V
Backlight Supply Voltage	V _{LED}	-	3.2	3.3	3.4	V
Backlight Supply Current	I _{LED}	V _{LED} = 3.3V	30	60	75	mA
Heater panel resistance	R _H +/-	-	5	20	35	Ω
Heater Voltage Supply	V _H	-	-	12	15	V
Heater Current	I _H	V _H = 12.0V	0.48	0.6	1	A
Heater Power	W _H	-	5.76	7.2	12	W

¹Heater **MUST** be activated when operating temperature drops below -20°C

²Heater measured using digital multi-meter

Optical Characteristics

Item	Symbol	Condition	Min.	Typ.	Max.	Unit
Optimal Viewing Angles	Top	CR ≥ 2	-	20	-	°
	Bottom		-	40	-	°
	Left		-	40	-	°
	Right		-	40	-	°
Contrast Ratio	CR	-	2	4	10	-
Response Time	Rise	T _{OP} = 25°C	-	135	240	ms
	Fall		-	235	325	ms

Controller Information

Built-in ST7565P controller.

Please download specification at

https://www.newhavendisplay.com/resources_dataFiles/datasheets/LCDs/ST7565P.pdf

Timing Characteristics

The Serial Interface

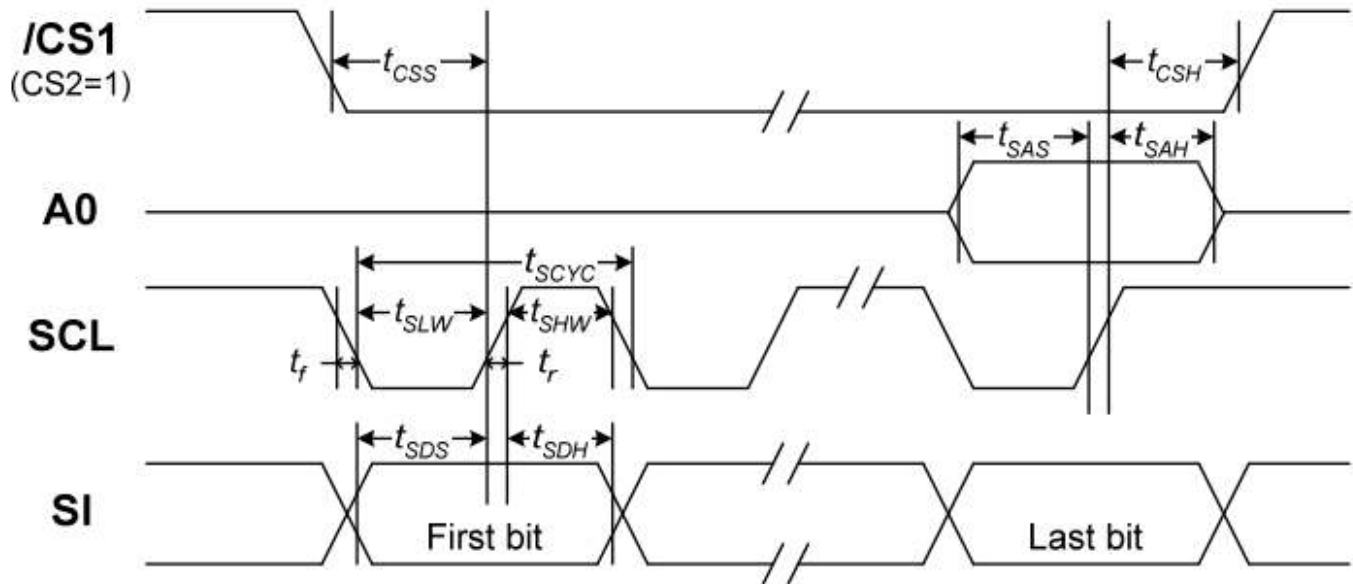

Item	Signal	Symbol	Condition	Rating		Units
				Min.	Max.	
Serial Clock Period	SCL	t_{SCYC}		50	—	ns
SCL "H" pulse width		t_{SHW}		25	—	
SCL "L" pulse width		t_{SLW}		25	—	
Address setup time	A0	t_{SAS}		20	—	
Address hold time		t_{SAH}		10	—	
Data setup time	SI	t_{SDS}		20	—	
Data hold time		t_{SDH}		10	—	
CS-SCL time	CS	t_{CSS}		20	—	
CS-SCL time		t_{CSH}		40	—	

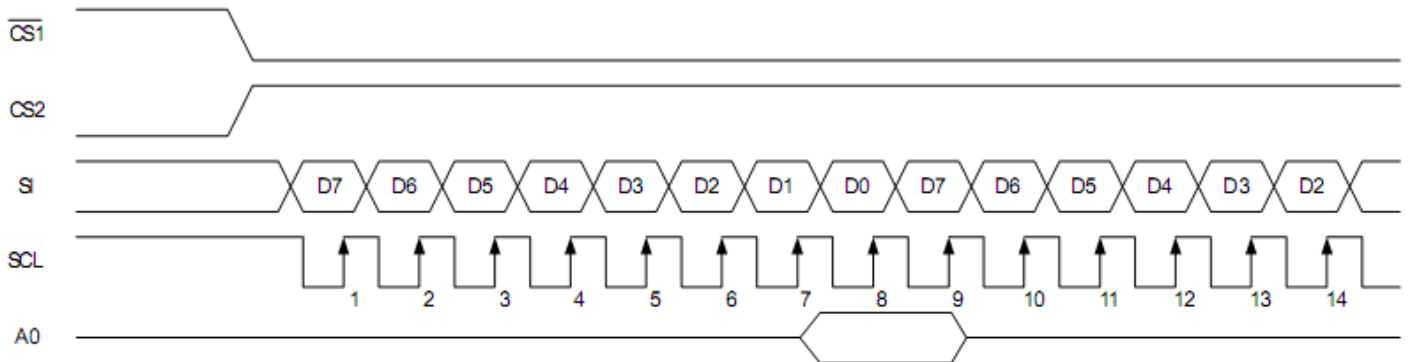

Table of Commands

Command	Command Code									Function			
	A0	/RD	/WR	D7	D6	D5	D4	D3	D2		D1	D0	
(1) Display ON/OFF	0	1	0	1	0	1	0	1	1	1	0	1	LCD display ON/OFF 0: OFF, 1: ON
(2) Display start line set	0	1	0	0	1	Display start address						0	Sets the display RAM display start line address
(3) Page address set	0	1	0	1	0	1	1	Page address				0	Sets the display RAM page address
(4) Column address set upper bit	0	1	0	0	0	0	1	Most significant column address				0	Sets the most significant 4 bits of the display RAM column address.
Column address set lower bit	0	1	0	0	0	0	0	Least significant column address				0	Sets the least significant 4 bits of the display RAM column address.
(5) Status read	0	0	1	Status				0	0	0	0	0	Reads the status data
(6) Display data write	1	1	0	Write data								0	Writes to the display RAM
(7) Display data read	1	0	1	Read data								0	Reads from the display RAM
(8) ADC select	0	1	0	1	0	1	0	0	0	0	0	0	Sets the display RAM address SEG output correspondence 0: normal, 1: reverse
(9) Display normal/reverse	0	1	0	1	0	1	0	0	1	1	0	1	Sets the LCD display normal/reverse 0: normal, 1: reverse
(10) Display all points ON/OFF	0	1	0	1	0	1	0	0	1	0	0	1	Display all points 0: normal display 1: all points ON
(11) LCD bias set	0	1	0	1	0	1	0	0	0	1	0	1	Sets the LCD drive voltage bias ratio 0: 1/9 bias, 1: 1/7 bias (ST7565P)
(12) Read/modify/write	0	1	0	1	1	1	0	0	0	0	0	0	Column address increment At write: +1 At read: 0
(13) End	0	1	0	1	1	1	0	1	1	1	0	0	Clear read/modify/write
(14) Reset	0	1	0	1	1	1	0	0	0	1	0	0	Internal reset
(15) Common output mode select	0	1	0	1	1	0	0	0	*	*	*	*	Select COM output scan direction 0: normal direction 1: reverse direction
(16) Power control set	0	1	0	0	0	1	0	1	Operating mode			0	Select internal power supply operating mode
(17) V ₀ voltage regulator internal resistor ratio set	0	1	0	0	0	1	0	0	Resistor ratio			0	Select internal resistor ratio(R _b /R _a) mode
(18) Electronic volume mode set Electronic volume register set	0	1	0	1	0	0	0	0	0	0	0	1	Set the V ₀ output voltage electronic volume register
(20) Booster ratio set	0	1	0	1	1	1	1	1	0	0	0	0	select booster ratio 00: 2x,3x,4x 01: 5x 11: 6x
(21) Power saver													Display OFF and display all points ON compound command
(22) NOP	0	1	0	1	1	1	0	0	0	1	1	1	Command for non-operation
(23) Test	0	1	0	1	1	1	1	*	*	*	*	*	Command for IC test. Do not use this command

Example Initialization Program

```
.....  
Sub Command  
Reset P3.7  
Reset P3.4  
For Writecount = 1 To 8  
Rotate A , Left , 1  
Reset P3.1  
P1 = A  
Set P3.1  
Next Writecount  
Set P3.7  
End Sub
```

```
.....  
Sub Write  
Reset P3.7  
Set P3.4  
For Writecount = 1 To 8  
Rotate A , Left , 1  
Reset P3.1  
P1 = A  
Set P3.1  
Next Writecount  
Set P3.7  
End Sub
```

```
.....  
Sub Init  
Waitms 100  
A = &HA0  
Call Command  
A = &HAE  
Call Command  
A = &HC0  
Call Command  
A = &HA2  
Call Command  
A = &H2F  
Call Command  
A = &H26  
Call Command  
A = &H81  
Call Command  
A = &H11  
Call Command  
A = &HAF  
Call Command  
End Sub
```

Quality Information

Test Item	Content of Test	Test Condition	Note
High Temperature storage	Endurance test applying the high storage temperature for a long time.	+80°C , 96hrs	2
Low Temperature storage	Endurance test applying the low storage temperature for a long time.	-40°C , 96hrs	1,2
High Temperature Operation	Endurance test applying the electric stress (voltage & current) and the high thermal stress for a long time.	+70°C , 96hrs	2
Low Temperature Operation	Endurance test applying the electric stress (voltage & current) and the low thermal stress for a long time.	-40°C /-20°C, 96hrs	1,2
High Temperature / Humidity Operation	Endurance test applying the electric stress (voltage & current) and the high thermal with high humidity stress for a long time.	+40°C , 90% RH , 96hrs	1,2
Thermal Shock resistance	Endurance test applying the electric stress (voltage & current) during a cycle of low and high thermal stress.	-40°C /-20°C , 60min --> 70°C , 60min = 1 cycle For 20 cycles	
Vibration test	Endurance test applying vibration to simulate transportation and use.	10-50Hz , Acceleration of Gravity:5G 30 min in each of 3 directions X,Y,Z	3
Static electricity test	Endurance test applying electric static discharge.	Air: ±8kV 150pF/330Ω, 5 Times Contact: ±4kV 150pF/330Ω, 5 Times	

Note 1: No condensation to be observed.

Note 2: Conducted after 4 hours of storage at 25°C, 0%RH.

Note 3: Test performed on product itself, not inside a container.

Precautions for using LCDs/LCMs

See Precautions at www.newhavendisplay.com/specs/precautions.pdf

Warranty Information and Terms & Conditions

http://www.newhavendisplay.com/index.php?main_page=terms