

LOC	DIST	REVISIONS					
GP	00	P	LTR	DESCRIPTION	DATE	DWN	APVD
			J	REVISED PER ECO-19-002530	21MAY2019	AP	DG

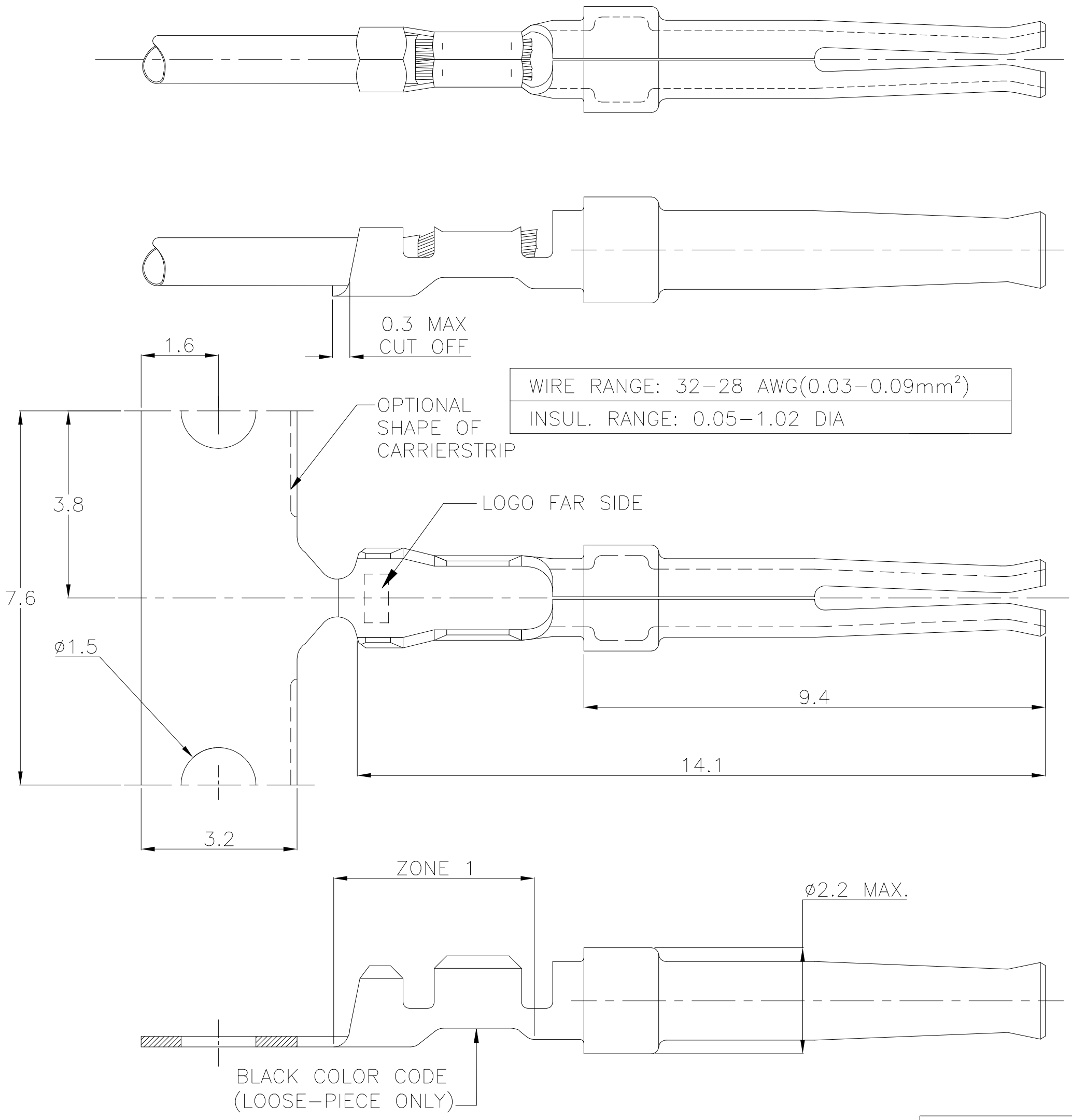

- 1 FOR MINI-APPLICATOR CRIMPING.
- 2 FOR STANDARD APPLICATOR CRIMPING.
- 3 FOR REEL-FEED HANDTOOL CRIMPING, 500 CONTACTS ON A SMALL REEL.
- 4. MATERIAL: PHOSPHOR BRONZE.
- 5 UNDERCOATING: 1.3µm NICKEL. SELECTIVE: 0.8µm GOLD. REMAINDER: GOLD FLASH.
- 6 UNDERCOATING: 1.3µm NICKEL. SELECTIVE: 0.8µm GOLD. ZONE 1: BRIGHT TIN.
- 7 UNDERCOATING: 0.8µm NICKEL. SELECTIVE: 0.4µm GOLD. REMAINDER: GOLD FLASH.
- 8 UNDERCOATING: 0.8µm NICKEL. SELECTIVE: 0.4µm GOLD. ZONE 1: BRIGHT TIN.
- 9 UNDERCOATING: 1.3µm NICKEL. SELECTIVE: 1.3µm GOLD. REMAINDER: GOLD FLASH.
- 10 UNDERCOATING: 0.8µm NICKEL. SELECTIVE: 2.0µm GOLD. REMAINDER: BRIGHT TIN.
- 11 UNDERCOATING: 0.8µm NICKEL. SELECTIVE: 0.2µm GOLD. REMAINDER: GOLD FLASH.
- 12 UNDERCOATING: 0.8µm NICKEL. SELECTIVE: 0.2µm GOLD. ZONE 1: BRIGHT TIN.
- 13 OBSOLETE PARTS: OBSOLETE CIS STREAMLINING PER D. RENAUD/ D. SINISI

13	12	1-166998-3	-	-	1-166996-3
13	11	1-166998-2	-	-	1-166996-2
13	9	166998-7	-	-	166996-7
	8	166998-6	-	-	166996-6
	7	166998-5	-	-	166996-5
	10	-	-	-	166996-4
	6	166998-3	-	-	166996-3
	5	166998-2	-	-	166996-2
	FINISH	LOOSE PIECE	PART NUMBER 3	PART NUMBER 2	PART NUMBER 1

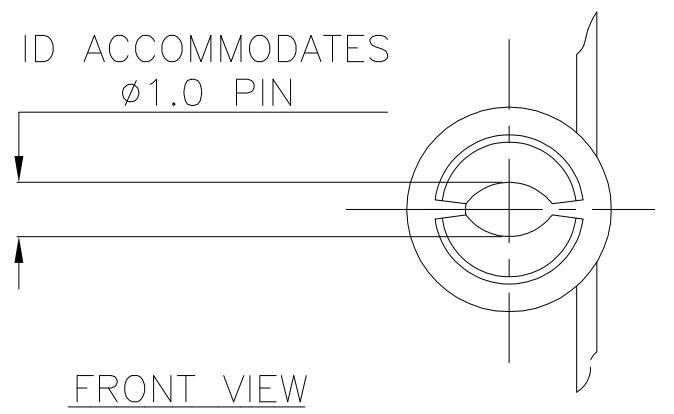

THIS DRAWING IS A CONTROLLED DOCUMENT.		DWN C. VALENTINE 08NOV2011			
DIMENSIONS: mm		CHK C. ROHDE 08NOV2011			
TOLERANCES UNLESS OTHERWISE SPECIFIED:		APVD C. ROHDE 08NOV2011	NAME		
0 PLC ± -		PRODUCT SPEC			
1 PLC ± 0.127		108-40005			
2 PLC ± -		APPLICATION SPEC			
3 PLC ± -		114-10000			
4 PLC ± -		WEIGHT			
ANGLES ± -		A3 00779 C=166996			
MATERIAL -		FINISH SEE TABLE			
		CUSTOMER DRAWING			RESTRICTED TO -
		SCALE NTS	SHEET 1 OF 1	REV J	