



AND0041R

Quad-band GSM/GPRS/Polar EDGE Power Amplifier Module with Integrated Power Control

PRELIMINARY DATA SHEET - REV 1.3

FEATURES

- Internal Reference Voltage
- Integrated Power Control Scheme
- InGaP HBT Technology
- ESD Protection on All Pins (2.5 kV)
- Low profile 1.3 mm
- Small Package Outline 7 mm x 7 mm
- EGPRS Capable (class 12)
- RoHS Compliant Package, 250 °C MSL-3

GMSK MODE

- Integrated power control (CMOS)
- +35.5 dBm GSM850/900 Output Power
- +33.5 dBm DCS/PCS Output Power
- 55 % GSM850/900 PAE
- 53 % DCS/PCS PAE
- Power control range > 50 dB

EDGE MODE

- +29 dBm GSM850/900 Output Power
- +28.5 dBm DCS/PCS Output Power
- 25 % GSM850/900 PAE
- 30 % DCS/PCS PAE
- 64 dB Typical ACPR (400 kHz)
- 74 dB Typical ACPR (600 kHz)

APPLICATIONS

- Dual/Tri/Quad Band Handsets and PDAs
- Dual/Tri/Quad Band Wireless Data Cards

PRODUCT DESCRIPTION

This power amplifier module supports dual, tri and quad band applications for GMSK and 8-PSK modulation schemes using an open loop polar architecture. There are two amplifier chains, one to support GSM850/900 bands, the other for DCS/PCS bands. Each amplification chain is optimized for excellent EDGE efficiency, power, and linearity in a Polar loop environment while maintaining high efficiency in the GSM/GPRS mode.

The module includes an internal reference voltage and integrated power control scheme for use in both GMSK and 8-PSK operation. This facilitates fast and easy production calibration and reduces the number of external components required to complete a power control function.

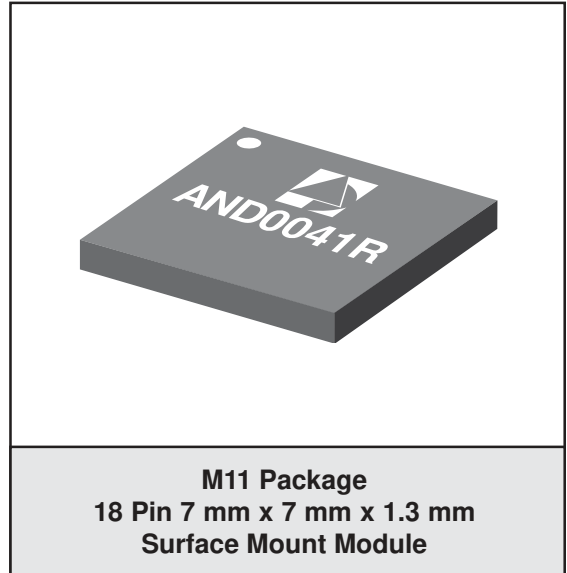

The amplifier's power control range is typically 55 dB, with the output power set by applying an analog voltage to V_{RAMP}. All of the RF ports for this device are internally matched to 50Ω.

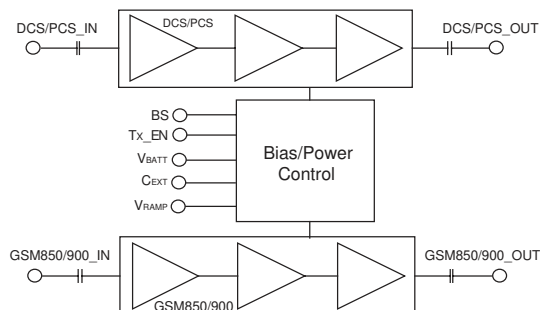

Figure 1: Block Diagram

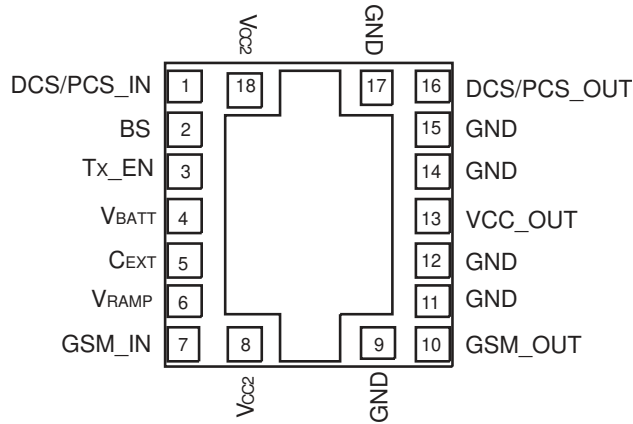

Figure 2: Pinout (X - ray Top View)

Table 1: Pin Description

PIN	NAME	DESCRIPTION	PIN	NAME	DESCRIPTION
1	DCS/PCS_IN	DCS/PCS RF Input	10	GSM_OUT	GSM850/900 RF Output
2	BS	Band Select Logic Input	11	GND	Ground
3	TX_EN	TX Enable Logic Input	12	GND	Ground
4	VBATT	Battery Supply Connection	13	VCC_OUT	Control Voltage Output which must be connected to Vcc2, no decoupling
5	CEXT	Bypass	14	GND	Ground
6	VRAMP	Analog Signal used to control the output power	15	GND	Ground
7	GSM_IN	GSM850/900 RF Input	16	DCS/PCS_OUT	DCS/PCS RF Output
8	Vcc2	VCC Control Input for GSM850/900 Pre-amplifier	17	GND	Ground
9	GND	Ground	18	Vcc2	Vcc Control Input for DCS/PCS Pre-amplifier

ELECTRICAL CHARACTERISTICS

Table 2: Absolute Maximum Ratings

PARAMETER	MIN	MAX	UNITS
Supply Voltage (V_{BATT})	-	+7	V
RF Input Power (RF_{IN})	-	11	dBm
Control Voltage (V_{RAMP})	-0.3	1.8	V
Storage Temperature (T_{STG})	-55	150	°C

Stresses in excess of the absolute ratings may cause permanent damage. Functional operation is not implied under these conditions. Exposure to absolute ratings for extended periods of time may adversely affect reliability.

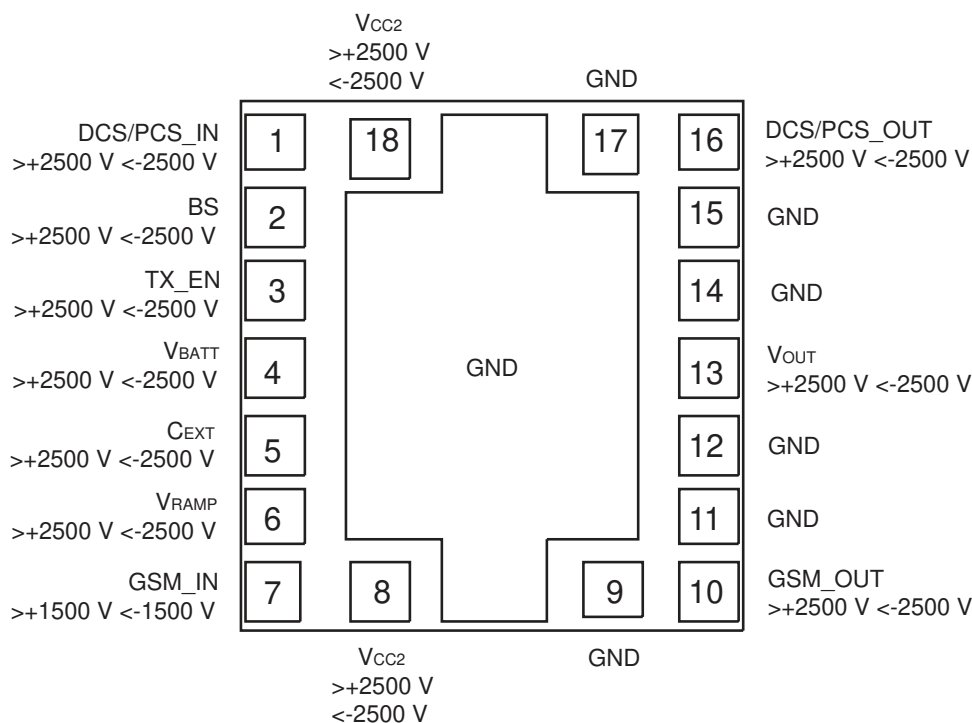

Figure 3: ESD Pin Rating

ELECTROSTATIC DISCHARGE SENSITIVITY

The AND0041R part was tested to determine the ESD sensitivity of each package pin with respect to ground. All the package pins were subjected to an ESD pulse event using the Human Body Model outlined in JESD22-A114C.01 in either polarity with re-

spect to ground. The pre and post test I-V characteristics of each pin are recorded. The ratings on each pin require that it sustain the ESD event and show no degradation.

Table 4: Operating Conditions

PARAMETER	MIN	TYP	MAX	UNITS	COMMENTS
Case temperature (T _C)	-20	-	85	°C	
Supply voltage (V _{BATT})	3.0	3.5	4.8	V	
Power supply leakage current	-	1	10	μA	V _{BATT} = 4.8 V, V _{RAMP} = 0 V, TX_EN = LOW No RF applied
Control Voltage Range	0.2	-	1.6	V	
Turn on Time (T _{ON})	-	-	1	μs	V _{RAMP} = 0.2 V, TX_EN = LOW → HIGH P _{IN} = 5 dB
Turn Off Time (T _{OFF})	-	-	1	μs	V _{RAMP} = 0.2 V, TX_EN = LOW → HIGH P _{IN} = 5 dB
Rise Time (T _{RISE})	-	-	1	μs	P _{OUT} = -10 dBm → P _{MAX} (within 0.2 dB)
Fall Time (T _{FALL})	-	-	1	μs	P _{OUT} = P _{MAX} → -10 dBm (within 0.2 dB)
V _{RAMP} Input Capacitance	-	3	-	pF	
V _{RAMP} Input Current	-	-	10	μA	
Duty Cycle	-	-	50	%	

The device may be operated safely over these conditions; however, parametric performance is guaranteed only over the conditions defined in the electrical specifications.

Table 5: Digital Inputs

PARAMETER	SYMBOL	MIN	TYP	MAX	UNITS
Logic High Voltage	V _{IH}	1.2	-	3.0	V
Logic Low Voltage	V _{IL}	-	-	0.5	V
Logic High Current	I _{IH}	-	-	30	μA
Logic Low Current	I _{IL}	-	-	30	μA

Table 6: Logic Control Table

OPERATIONAL MODE	BS	TX_EN
GSM850/900	LOW	HIGH
DCS/PCS	HIGH	HIGH
PA DISABLED	-	LOW

Table 7: Electrical Characteristics for GSM850 GMSK mode
**Unless otherwise specified: $V_{BATT} = 3.5$ V, $P_{IN} = 3.0$ dBm, Pulse Width = 1154 μ s, Duty = 25%,
 $Z_{IN} = Z_{OUT} = 50$ Ω , $T_C = 25$ $^{\circ}$ C, $V_{RAMP} = 1.6$ V, BS = LOW, TX_EN = HIGH**

PARAMETER	MIN	TYP	MAX	UNIT	COMMENTS
Operating Frequency (F_{IN})	824	-	849	MHz	
Input Power (P_{IN})	0	3	5	dBm	
Output Power (P_{MAX})	34.5	35.8	-	dBm	Freq = 824 to 849 MHz
Degraded Output Power (P_{OUT})	32.8	33.8	-	dBm	$V_{BATT} = 3.0$ V, $T_C = 85$ $^{\circ}$ C $P_{IN} = 0$ dBm
PAE @ P_{MAX}	48	53	-	%	Freq = 824 to 849 MHz
Forward Isolation 1	-	-36	-30	dBm	TX_EN = 0 V, $P_{IN} = 5$ dBm
Forward Isolation 2	-	-30	-20	dBm	TX_EN = HIGH, $V_{RAMP} = 0.2$ V $P_{IN} = 5$ dBm
Cross Isolation ($2F_o$, $3F_o$ @ DCS/PCS port)	-	-27	-20	dBm	$P_{OUT} \leq 34.5$ dBm
Second Harmonic	-	-20	-10	dBm	$P_{OUT} \leq 34.5$ dBm
Third Harmonic	-	-40	-15	dBm	$P_{OUT} \leq 34.5$ dBm
$n * f_o$ ($n \geq 4$), $F_o \leq 12.75$ GHz	-	-30	-10	dBm	$P_{OUT} \leq 34.5$ dBm
Stability	VSWR = 8:1 All Phases, $P_{OUT} \leq 34.5$ dBm				
	-	-	-36	dBm	$F_{OUT} < 1$ GHz
	-	-	-30	dBm	$F_{OUT} > 1$ GHz
Ruggedness	No Permanent Degradation VSWR 10:1, All Phase Angles				$P_{OUT} \leq 34.5$ dBm
RX Noise Power	-	-84	-82	dBm	$F_{TX} = 849$ MHz, RBW = 100 kHz, $F_{RX} = 869$ to 894 MHz, $P_{OUT} \leq 34.5$ dBm
Input Return Loss	-	1.5:1	2.5:1	VSWR	$P_{OUT} \leq 34.5$ dBm

Table 8: Electrical Characteristics for GSM850 8PSK mode
Unless otherwise specified: $V_{BATT} = 3.5\text{ V}$, $P_{IN} = 3.0\text{ dBm}$, Pulse Width = 1154 μs , Duty = 25%
 $Z_{IN} = Z_{OUT} = 50\ \Omega$, $T_c = 25\ ^\circ\text{C}$, BS = LOW, TX_EN = HIGH

PARAMETER	MIN	TYP	MAX	UNIT	COMMENTS
Operating Frequency (F_{IN})	824	-	849	MHz	
Input Power	0	3	5	dBm	
PAE	20	25	-	%	$F_{IN} = 824\text{ to }849\text{ MHz}$ $P_{OUT}\text{ set} = +29\text{ dBm}$
ACPR 200 kHz 400 kHz 600 kHz 1800 kHz	- - - -	-39 -62 -74 -74	-34 -58 -64 -68	dBc/30 kHz dBc/30 kHz dBc/30 kHz dBc/100 kHz	All conditions under Polar operation $P_{OUT} = +29\text{ dBm}$
EVM	-	1	5	%	All Conditions under Polar operation $P_{OUT} = +29\text{ dBm}$

Table 9: Electrical Characteristics for GSM900 GMSK mode
**Unless otherwise specified: $V_{BATT} = 3.5$ V, $P_{IN} = 3.0$ dBm, Pulse Width = 1154 μ s, Duty = 25%,
 $Z_{IN} = Z_{OUT} = 50$ Ω , $T_C = 25$ $^{\circ}$ C, $V_{RAMP} = 1.6$ V, BS = HIGH, TX_EN = HIGH**

PARAMETER	MIN	TYP	MAX	UNIT	COMMENTS
Operating Frequency (F_{IN})	880	-	915	MHz	
Input Power (P_{IN})	0	3	5	dBm	
Output Power (P_{MAX})	34.5	35.5	-	dBm	Freq = 880 to 915 MHz
Degraded Output Power (P_{OUT})	32.5	33.5	-	dBm	$V_{BATT} = 3.0$ V, $T_C = 85$ $^{\circ}$ C $P_{IN} = 0$ dBm
PAE @ P_{MAX}	50	55	-	%	Freq = 880 to 915 MHz
Forward Isolation 1	-	-35	-30	dBm	TX_EN = 0 V, $P_{IN} = 5$ dBm
Forward Isolation 2	-	-30	-20	dBm	TX_EN = HIGH, $V_{RAMP} = 0.2$ V $P_{IN} = 5$ dBm
Cross Isolation ($2F_o$, $3F_o$ @ DCS/PCS port)	-	-29	-20	dBm	$P_{OUT} \leq 34.5$ dBm
Second Harmonic	-	-25	-10	dBm	$P_{OUT} \leq 34.5$ dBm
Third Harmonic	-	-40	-15	dBm	$P_{OUT} \leq 34.5$ dBm
$n * f_o$ ($n \geq 4$), $F_o \leq 12.75$ GHz	-	-29	-8	dBm	$P_{OUT} \leq 34.5$ dBm
Stability	VSWR = 8:1 All Phases, $P_{OUT} \leq 34.5$ dBm				
	-	-	-36	dBm	$F_{OUT} < 1$ GHz
	-	-	-30	dBm	$F_{OUT} > 1$ GHz
Ruggedness	No Permanent Degradation VSWR 10:1, All Phase Angles			$P_{OUT} \leq 34.5$ dBm	
RX Noise Power	-	-80	-79	dBm	$F_{TX} = 915$ MHz, RBW = 100 kHz, $F_{RX} = 925$ to 935 MHz, $P_{OUT} \leq 34.5$ dBm
	-	-85	-83	dBm	$F_{TX} = 915$ MHz, RBW = 100 kHz, $F_{RX} = 935$ to 960 MHz, $P_{OUT} \leq 34.5$ dBm
Input Return Loss	-	1.5:1	2.5:1	VSWR	$P_{OUT} \leq 34.5$ dBm

Table 10: Electrical Characteristics for GSM900 8PSK mode

Unless otherwise specified: $V_{BATT} = 3.5\text{ V}$, $P_{IN} = 3.0\text{ dBm}$, Pulse Width = 1154 μs , Duty = 25%,
 $Z_{IN} = Z_{OUT} = 50\ \Omega$, $TC = 25\ ^\circ\text{C}$, $BS = \text{HIGH}$, $TX_EN = \text{HIGH}$

PARAMETER	MIN	TYP	MAX	UNIT	COMMENTS
Operating Frequency (F_{IN})	880	-	915	MHz	
Input Power	0	3	5	dBm	
PAE	20	25	-	%	$F_{IN} = 880\text{ to }915\text{ MHz}$ $P_{OUT}\text{ set} = +29\text{ dBm}$
ACPR 200 kHz 400 kHz 600 kHz 1800 kHz	- - - -	-38 -62 -73 -74	-34 -58 -64 -68	dBc/30 kHz dBc/30 kHz dBc/30 kHz dBc/100 kHz	All conditions under Polar operation $P_{OUT} = +29\text{ dBm}$
EVM	-	1	5	%	All Conditions under Polar operation $P_{OUT} = +29\text{ dBm}$

Table 11: Electrical Characteristics for DCS GMSK mode
**Unless otherwise specified: $V_{BATT} = 3.5\text{ V}$, $V_{RAMP} = 1.6\text{ V}$, Pulse Width = 1154 μs , Duty = 25%,
 $Z_{IN} = Z_{OUT} = 50\ \Omega$, $T_C = 25\ ^\circ\text{C}$, BS = HIGH, TX_EN = HIGH**

PARAMETER	MIN	TYP	MAX	UNIT	COMMENTS
Operating Frequency (F_{IN})	1710	-	1785	MHz	
Input Power (P_{IN})	0	3	5	dBm	
Output Power (P_{MAX})	32.5	33.5	-	dBm	Freq = 1710 to 1785 MHz
Degraded Output Power (P_{OUT})	30.5	31.5	-	dBm	$V_{BATT} = 3.0\text{ V}$, $T_C = 85\ ^\circ\text{C}$ $P_{IN} = 0\text{ dBm}$
PAE @ P_{MAX}	48	53	-	%	Freq = 1710 to 1785 MHz
Forward Isolation 1	-	-40	-33	dBm	TX_EN = 0 V, $P_{IN} = 5\text{ dBm}$
Forward Isolation 2	-	-27	-20	dBm	TX_EN = HIGH, $V_{RAMP} = 0.2\text{ V}$ $P_{IN} = 5\text{ dBm}$
Second Harmonic	-	-25	-10	dBm	$P_{OUT} \leq 32.5\text{ dBm}$
Third Harmonic	-	-27	-15	dBm	$P_{OUT} \leq 32.5\text{ dBm}$
$n * f_0$ ($n \geq 4$), $F_0 \leq 12.75\text{ GHz}$	-	-34	-10	dBm	$P_{OUT} \leq 32.5\text{ dBm}$
Stability	VSWR = 8:1 All Phases, $P_{OUT} \leq 32.5\text{ dBm}$				
	-	-	-36	dBm	$F_{OUT} < 1\text{ GHz}$
	-	-	-30	dBm	$F_{OUT} > 1\text{ GHz}$
Ruggedness	No Permanent Degradation VSWR 10:1, All Phase Angles			$P_{OUT} \leq 32.5\text{ dBm}$	
RX Noise Power	-	-85	-80	dBm	$F_{TX} = 1785\text{ MHz}$, RBW = 100 kHz, $F_{RX} = 1805\text{ to }1880\text{ MHz}$, $P_{OUT} \leq 32.5\text{ dBm}$
Input Return Loss	-	1.5:1	2.5:1	VSWR	$P_{OUT} \leq 32.5\text{ dBm}$

Table 12: Electrical Characteristics for DCS 8PSK mode

Unless otherwise specified: $V_{BATT} = 3.5\text{ V}$, $P_{IN} = 3.0\text{ dBm}$, Pulse Width = 1154 μs , Duty = 25%,
 $Z_{IN} = Z_{OUT} = 50\ \Omega$, $TC = 25\ ^\circ\text{C}$, BS = HIGH, TX_EN = HIGH

PARAMETER	MIN	TYP	MAX	UNIT	COMMENTS
Operating Frequency (F_{IN})	1710	-	1785	MHz	
Input Power	0	3	5	dBm	
PAE	25	30	-	%	$F_{IN} = 1710\text{ to }1785\text{ MHz}$ $P_{OUT}\text{ set} = +28.5\text{ dBm}$
ACPR 200 kHz 400 kHz 600 kHz 1800 kHz	- - - -	-38 -64 -77 -76	-34 -58 -64 -68	dBc/30 kHz dBc/30 kHz dBc/30 kHz dBc/100 kHz	All conditions under Polar operation $P_{OUT} = +28.5\text{ dBm}$
EVM	-	1	5	%	All Conditions under Polar operation $P_{OUT} = +28.5\text{ dBm}$

Table 13: Electrical Characteristics for PCS GMSK mode
**Unless otherwise specified: $V_{BATT} = 3.5\text{ V}$, $V_{RAMP} = 1.6\text{ V}$, Pulse Width = 1154 μs , Duty = 25%,
 $Z_{IN} = Z_{OUT} = 50\ \Omega$, $T_C = 25\ ^\circ\text{C}$, BS = HIGH, TX_EN = HIGH**

PARAMETER	MIN	TYP	MAX	UNIT	COMMENTS
Operating Frequency (F_{IN})	1850	-	1910	MHz	
Input Power (P_{IN})	0	3	5	dBm	
Output Power (P_{MAX})	32.3	33.3	-	dBm	Freq = 1850 to 1910 MHz
Degraded Output Power (P_{OUT})	30.3	31.3	-	dBm	$V_{BATT} = 3.0\text{ V}$, $T_C = 85\ ^\circ\text{C}$ $P_{IN} = 0\text{ dBm}$
PAE @ P_{MAX}	47	53	-	%	Freq = 1850 to 1910 MHz
Forward Isolation 1	-	-39	-32	dBm	TX_EN = 0 V, $P_{IN} = 5\text{ dBm}$
Forward Isolation 2	-	-27	-20	dBm	TX_EN = HIGH, $V_{RAMP} = 0.2\text{ V}$ $P_{IN} = 5\text{ dBm}$
Second Harmonic	-	-17	-10	dBm	$P_{OUT} \leq 32.3\text{ dBm}$
Third Harmonic	-	-35	-15	dBm	$P_{OUT} \leq 32.3\text{ dBm}$
$n * f_0$ ($n \geq 4$), $F_0 \leq 12.75\text{ GHz}$	-	-33	-10	dBm	$P_{OUT} \leq 32.3\text{ dBm}$
Stability	VSWR = 8:1 All Phases, $P_{OUT} \leq 32.3\text{ dBm}$				
	-	-	-36	dBm	$F_{OUT} < 1\text{ GHz}$
	-	-	-30	dBm	$F_{OUT} > 1\text{ GHz}$
Ruggedness	No Permanent Degradation VSWR 10:1, All Phase Angles				$P_{OUT} \leq 32.3\text{ dBm}$
RX Noise Power	-	-85	-80	dBm	$F_{TX} = 1910\text{ MHz}$, RBW = 100 kHz, $F_{RX} = 1930\text{ to }1990\text{ MHz}$, $P_{OUT} \leq 32.3\text{ dBm}$
Input Return Loss	-	1.5:1	2.5:1	VSWR	$P_{OUT} \leq 32.3\text{ dBm}$

Table 14: Electrical Characteristics for PCS 8PSK mode
**Unless otherwise specified: $V_{BATT} = 3.5\text{ V}$, $P_{IN} = 3.0\text{ dBm}$, Pulse Width = 1154 μs , Duty = 25%,
 $Z_{IN} = Z_{OUT} = 50\ \Omega$, $TC = 25\ ^\circ\text{C}$, $BS = \text{HIGH}$, $TX_EN = \text{HIGH}$**

PARAMETER	MIN	TYP	MAX	UNIT	COMMENTS
Operating Frequency (F_{IN})	1850	-	1910	MHz	
Input Power	0	3	5	dBm	
PAE	25	30	-	%	$F_{IN} = 1850\text{ to }1910\text{ MHz}$ $P_{OUT}\text{ set} = +28.5\text{ dBm}$
ACPR 200 kHz 400 kHz 600 kHz 1800 kHz	- - - -	-38 -64 -78 -77	-34 -58 -64 -68	dBc/30 kHz dBc/30 kHz dBc/30 kHz dBc/100 kHz	All conditions under Polar operation $P_{OUT} = +28.5\text{ dBm}$
EVM	-	1	5	%	All Conditions under Polar operation $P_{OUT} = +28.5\text{ dBm}$

APPLICATION INFORMATION

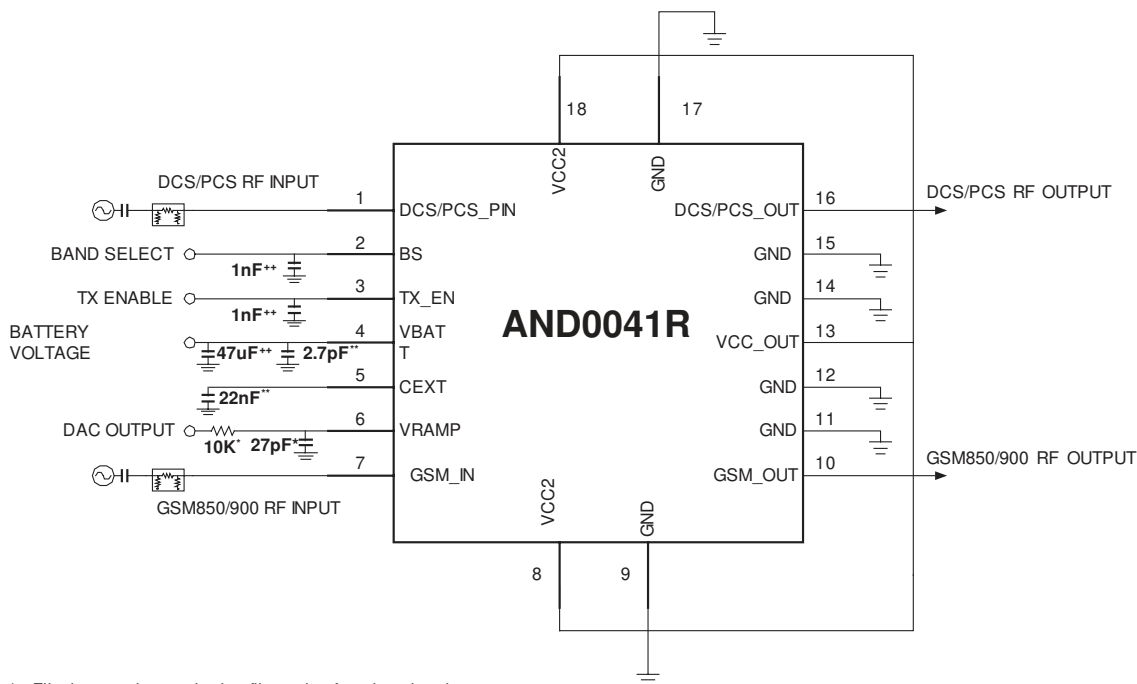

* Filtering may be required to filter noise from baseband.

** This component should be placed as close to the device pin as possible.

++ These components are recommended as good design practice for improving noise rejection characteristics. The values specified are not critical as they may not be required in the final application.

Figure 3: Recommended Application Circuit

AND0041R
PACKAGE OUTLINE

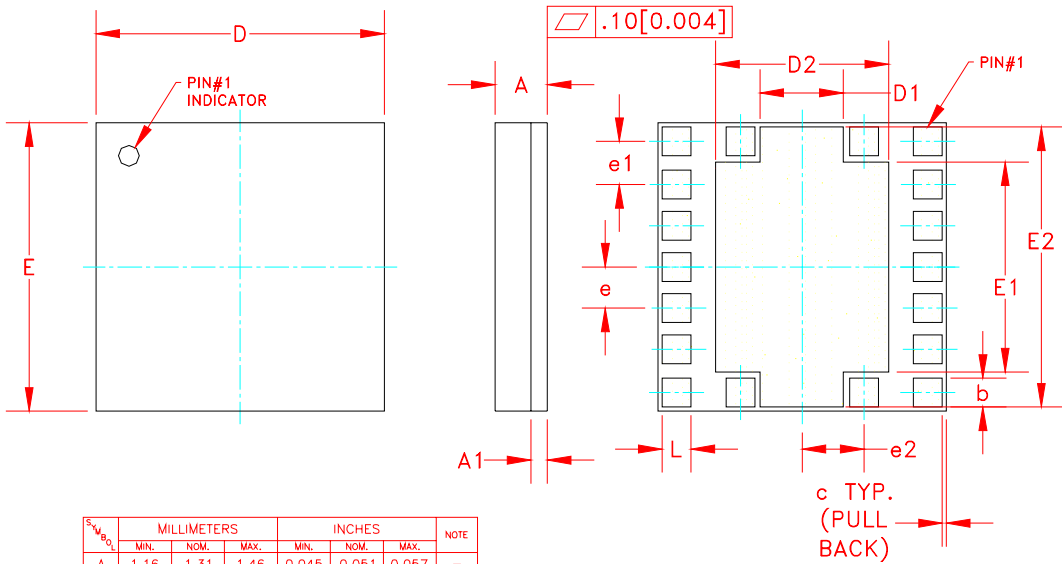

Symbol	MILLIMETERS			INCHES			NOTE
	MIN.	NOM.	MAX.	MIN.	NOM.	MAX.	
A	1.16	1.31	1.46	0.045	0.051	0.057	-
A1	-	0.30	-	-	0.012	-	-
b	0.67	-	0.73	0.026	-	0.028	-
c	-	0.10	-	-	0.004	-	-
D	6.88	7.00	7.12	0.270	0.275	0.280	-
D2	4.14	-	4.26	0.163	-	0.168	-
E	6.88	7.00	7.12	0.270	0.275	0.280	-
E1	5.07	-	5.13	0.199	-	0.202	-
E2	6.74	-	6.86	0.265	-	0.270	-
e	-	1.00	-	-	0.039	-	8X
e1	-	1.05	-	-	0.041	-	4X
e2	-	1.50	-	-	0.059	-	4X
L	0.67	-	0.73	0.026	-	0.028	-

NOTES:

1. CONTROLLING DIMENSIONS: MILLIMETERS
2. UNLESS SPECIFIED TOLERANCE=±0.076[0.003].
3. PADS (INCLUDING CENTER) SHOWN UNIFORM SIZE FOR REFERENCE ONLY. ACTUAL PAD SIZE AND LOCATION WILL VARY WITHIN MIN. AND MAX. DIMENSIONS ACCORDING TO SPECIFIC LAMINATE DESIGN.

Figure 4: Package Outline

TOP BRAND



1. PIN 1 INDICATOR: LASER MARK
2. ANADIGICS LOGO SIZE: X=0.040±0.010 Y=0.048±0.010
3. TEXT: TYPE: ELITE
SIZE: AS LARGE AS POSSIBLE
4. PART NUMBER: AND0041R
5. YEAR AND WORK WEEK: YYWW: YY = YEAR, WW = WORK WEEK
6. WAFER LOT NUMBER: LLLLL = WAFER LOT#
- SS = WAFER I.D.
7. BOM NUMBER: 047
8. COUNTRY CODE: CC = TH for THAILAND, TW for TAIWAN,
PH for PHILIPPINES, CH for CHINA,
ID for INDONESIA, HK for HONG KONG

Figure 5: Branding Specification

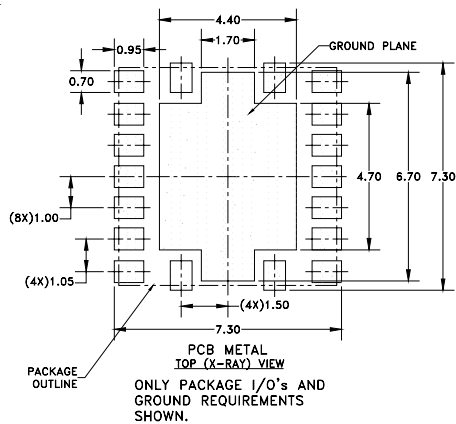

NOTES:

(1) UNLESS SPECIFIED DIMENSIONS ARE SYMMETRICAL ABOUT CENTER LINES SHOWN.

(2) DIMENSIONS IN MILLIMETERS.

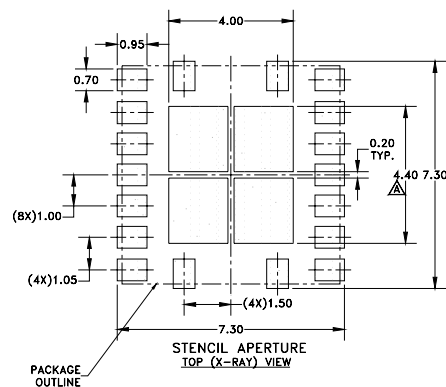
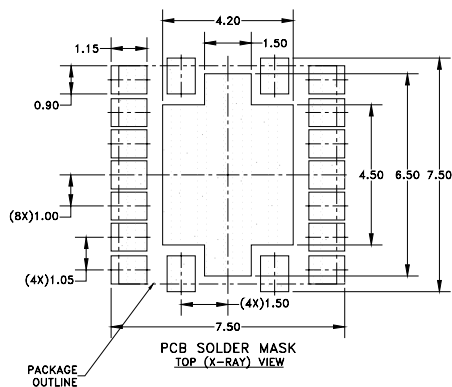

Figure 6: Recommended PCB Layout Information

ORDERING INFORMATION

ORDER NUMBER	TEMPERATURE RANGE	PACKAGE DESCRIPTION	COMPONENT PACKAGING
AND0041RM11P8	-20 °C to +85°C	RoHS-compliant 18 Pin 7 mm x 7 mm x 1.3 mm Surface Mount Module	Tape and Reel, 2500 pieces per reel
AND0041RM11P9	-20 °C to +85°C	RoHS-compliant 18 Pin 7 mm x 7 mm x 1.3 mm Surface Mount Module	Partial Tape and Reel



ANADIGICS, Inc.

141 Mount Bethel Road
Warren, New Jersey 07059, U.S.A.
Tel: +1 (908) 668-5000
Fax: +1 (908) 668-5132

URL: <http://www.anadigics.com>
E-mail: Mktg@anadigics.com

IMPORTANT NOTICE

ANADIGICS, Inc. reserves the right to make changes to its products or to discontinue any product at any time without notice. The product specifications contained in Advanced Product Information sheets and Preliminary Data Sheets are subject to change prior to a product's formal introduction. Information in Data Sheets have been carefully checked and are assumed to be reliable; however, ANADIGICS assumes no responsibilities for inaccuracies. ANADIGICS strongly urges customers to verify that the information they are using is current before placing orders.

WARNING

ANADIGICS products are not intended for use in life support appliances, devices or systems. Use of an ANADIGICS product in any such application without written consent is prohibited.