

# RI 4184

## DUAL USB 2.0

## FEEDTHRU FILTER

Panel mountable  
USB 2.0 480 Mbps  
feedthru filter



### OVERVIEW

The RI 4184 is a Feedthru Filter for all types of applications where USB signals need to be fed through a shielded wall.

### APPLICATION

Primarily designed to fit in Ranatec's Shield Boxes but can be used separately.

### ELECTRICAL INTERFACES

The physical connectors are located at each end. The filter is reciprocal, which means that the USB host can be attached to any of the connectors. RI 4184 can supply two USB devices with up to 900 mA.

### MECHANICAL INTERFACES

The RI 4184 is prepared for panel mounting with two threaded M3 screw holes. It is delivered with an EMI/RFI shielding gasket for simple and reliable mounting.

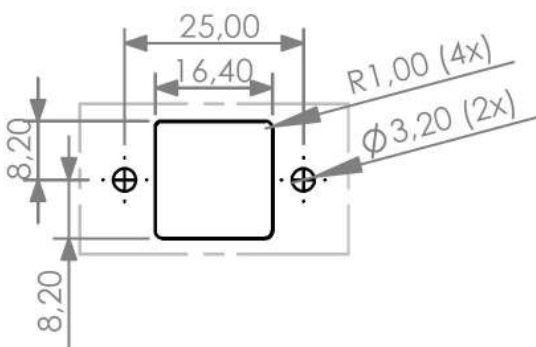

Panel cut-out recommendation (mm)

### FEATURES

- 75 dB filter suppression at 2.4, 5.8 and 7.125 GHz
- Fully USB 2.0 Hi-Speed 480 Mbps compatible
- Filtered USB device power feedthrough, 900mA
- Panel mountable

### SPECIFICATION

Connector front:	A, Rectangle (F)
Connector back:	A, Rectangle (F)
Material:	Aluminium
Dimensions:	36x71x22 mm
Weight:	90g

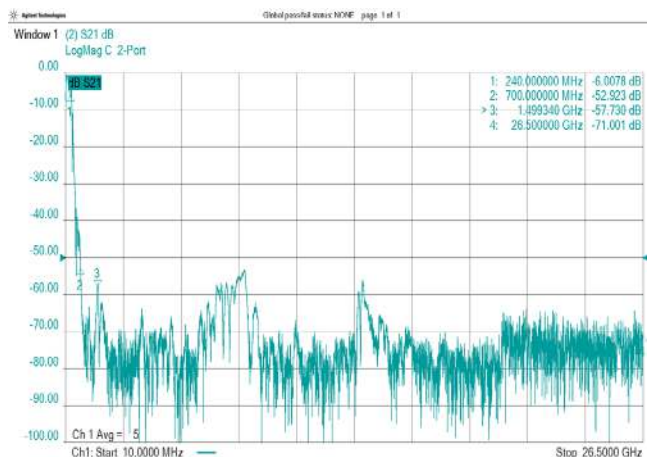

Typical filter suppression

### ORDERING

RI 4184 Dual USB 2.0 480 Mbps  
Feedthru Filter