

NLAS6234

Audio DPDT Switch with Noise Suppression

Description

The NLAS6234 is a DPDT switch featuring Popless noise suppression circuitry designed to prevent pass through of undesirable transient signals known as pops. Intended for audio systems within portable applications, it provides protection against audible pops that are generated when switching between two different audio sources, such as an amplifier and a CODEC.

The NLAS6234 incorporates two double throw switches controlled by a single select line which allows the system controller to simultaneously switch between two sets of signal lines. The Popless noise suppression circuitry controls the ON and OFF times that define the time interval when switching between the normally open (NO) and normally closed (NC) terminals. This allows any pops to be dissipated within the system before the switch settles into a closed position.

The NLAS6234 operates off of a single supply voltage, V_{CC} , and is available in an ultra-thin UQFN10 package.

Features

- Popless Noise Suppression Circuitry
- OVT up to +4.5 V on Control Pin
- $R_{ON} < 0.5 \Omega$ Across BCC Range, Typical
- THD $< 0.02 \%$, Typical
- Off Isolation = -70 dB, Typical
- Crosstalk Attenuation < -70 dB, Typical
- Ultra Small, Thin Package: 1.4 mm x 1.8 mm UQFN10
- This is a Pb-Free Device

Typical Applications

- Cell Phones, PDAs, MP3 and Other Portable Media Players



ON Semiconductor®

<http://onsemi.com>

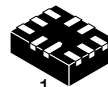

1

UQFN10
MU SUFFIX
CASE 488AT

MARKING DIAGRAM

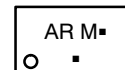

AR = Specific Device Code
M = Date Code
▪ = Pb-Free Package
(Note: Microdot may be in either location)

ORDERING INFORMATION

See detailed ordering and shipping information in the package dimensions section on page 8 of this data sheet.

NLAS6234

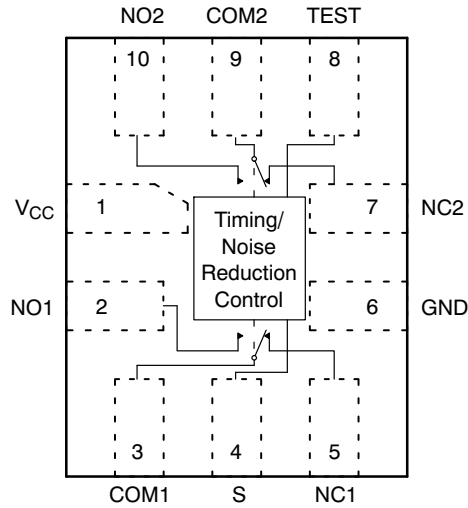

Figure 1. Pin Connections and Logic Diagram (Top View)

NOTE: Pin 8 is for ATE use only, not intended for end customer use.

PIN ASSIGNMENT

PIN	FUNCTION
V _{CC}	Supply Voltage
GND	Ground
S	Control Input Select Line
TEST	ATE Test Pin
NC1, NO1, NC2, NO2	Independent Channels
COM1, COM2	Common Channels

TRUTH TABLE

S	NC1, NC2	NO1, NO2
0	ON	OFF
1	OFF	ON

MAXIMUM RATINGS

Symbol	Pins	Rating	Value	Unit
V _{CC}	V _{CC}	Positive DC Supply Voltage	-0.5 to +5.5	V
V _{IS}	NOx, NCx, COMx	Analog Signal Voltage	-0.5 to V _{CC} + 0.5	V
V _{IN}	S	Control Input Voltage	-0.5 to +5.5	V
I _{IS_CON}	NOx, NCx, COMx	Analog Signal Continuous Current—Closed Switch	± 300	mA
I _{IS_PK}	NOx, NCx, COMx	Analog Signal Continuous Current 10% Duty Cycle	± 500	mA
I _{IN}	S	Control Input Current	± 20	mA
T _s	T _s	Storage Temperature	-65 to +150	°C

Stresses exceeding Maximum Ratings may damage the device. Maximum Ratings are stress ratings only. Functional operation above the Recommended Operating Conditions is not implied. Extended exposure to stresses above the Recommended Operating Conditions may affect device reliability.

RECOMMENDED OPERATING CONDITIONS

Symbol	Pins	Parameter	Min	Max	Unit
V _{CC}	V _{CC}	Positive DC Supply Voltage	2.7	4.5	V
V _{IS}	NOx, NCx, COMx	Analog Signal Voltage	GND	V _{CC}	V
V _{IN}	S	Control Input Voltage (OVT Protection)	GND	4.5	V
T _A		Operating Temperature Range	-40	+85	°C
t _r , t _f		Input Rise or Fall Time, S V _{CC} = 3.0 V to 3.6 V	0	10	ns/V

NLAS6234

DC ELECTRICAL CHARACTERISTICS

CONTROL INPUT (Typical: T = 25°C, V_{CC} = 3.3 V)

Symbol	Pins	Parameter	Test Conditions	V _{CC} (V)	-40°C to +85°C			Unit
					Min	Typ	Max	
V _{IH}	S	Minimum High-Level Input Voltage, Select Input		2.7 4.2	1.4 2.0	-	-	V
V _{IL}	S	Maximum Low-Level Input Voltage, Select Input		2.7 4.2	-	-	0.7 0.8	V
I _{IN}	S	Control Input Leakage Current	V _{IS} = GND	2.7-4.5	-	±100	±1000	nA

SUPPLY CURRENT AND LEAKAGE (Typical: T = 25°C, V_{CC} = 3.3 V, V_{IN} = V_{CC} or GND)

Symbol	Pins	Parameter	Test Conditions	V _{CC} (V)	-40°C to +85°C			Unit
					Min	Typ	Max	
I _{CC}	V _{CC}	Quiescent Supply Current	V _{IS} = V _{CC} or GND; I _D = 0 A	2.7 - 4.5	-	<100	1000	nA
I _{NC(OFF)} , I _{NO(OFF)}	NCx, NOx	OFF State Leakage Current	V _{COM} = 4.5 V V _{NO} , V _{NC} = 1.0 V	2.7 - 4.5	-	±10	±1000	nA
I _{OFF}		Power OFF Leakage Current	V _{IS} = GND	0	-	±10	±1000	nA

ON RESISTANCE (Typical: T = 25°C, V_{CC} = 3.3 V)

Symbol	Pins	Parameter	Test Conditions	V _{CC} (V)	-40°C to +85°C			Unit
					Min	Typ	Max	
R _{ON}		On-Resistance	V _{IN} = V _{IL} or V _{IN} = V _{IH} V _{IS} = 0 to V _{CC} ; I _{IS} = 100 mA	2.7 4.2	-	0.40 0.35	0.60 0.55	Ω
R _{FLAT}		On-Resistance Flatness	V _{IS} = 0 to V _{CC} ; I _{IS} = 100 mA	2.7 4.2	-	0.14 0.15	0.19 0.20	Ω
ΔR _{ON}		On-Resistance Match Between Channels	V _{IS} = 0 to V _{CC} ; I _{IS} = 100 mA	2.7 4.2	-	0.15 0.15	0.20 0.20	Ω

NLAS6234

AC ELECTRICAL CHARACTERISTICS

TIMING/FREQUENCY (Typical: T = 25°C, V_{CC} = 3.3 V, R_L = 50 Ω, C_L = 35 pF, f = 1 MHz)

Symbol	Pins	Parameter	Test Conditions	V _{CC} (V)	-40°C to +85°C			Unit
					Min	Typ	Max	
t _{ON}	-	Turn-ON Time (Figures 2, 3, 12)		2.7-4.5		11		ns
t _{OFF}	-	Turn-OFF Time (Figures 2, 3, 13)		2.7-4.5		9.0		ns
t _{BBM}	-	Minimum Break Before Make Time (Figure 14)	V _{IS} = 3.0, typ @ V _{CC} = 3.6 V	3.4-4.2		60		ms
BW	-	-3 dB Bandwidth	V _{IS} = 0 dB	2.7-4.5		36		MHz

ISOLATION (Typical: T = 25°C, V_{CC} = 3.3 V, R_L = 50 Ω, C_L = 5 pF)

Symbol	Pins	Parameter	Test Conditions	V _{CC} (V)	-40°C to +85°C			Unit
					Min	Typ	Max	
O _{IRR}	NOx	OFF-Isolation	V _{IS} = 1.0 V _{RMS} , f = 100 kHz	2.7-4.5		-70		dB
XTALK	COM 1 to COM 2	Crosstalk	V _{IS} = 1.0 V _{RMS} , f = 100 kHz	2.7-4.5		-98		dB
THD	-	Total Harmonic Distortion	R _L = 600 Ω, V _{COMn} = 2.0 V _{p-p}	3.0		0.02		%

CAPACITANCE (Typical: T = 25°C, V_{CC} = 3.3 V, R_L = 50 Ω, C_L = 5 pF, f = 1 MHz)

Symbol	Pins	Parameter	Test Conditions	V _{CC} (V)	-40°C to +85°C			Unit
					Min	Typ	Max	
C _{IN}	S	Select Input Capacitance		0		2.5		pF
C _{OFF}	NOx	OFF-Capacitance	V _{IS} = 3.3 V, S = 0 V	2.7-4.5		72		pF
C _{ON}	COMx to NCx	ON-Capacitance	S = 0 V	2.7-4.5		113		pF

NLAS6234

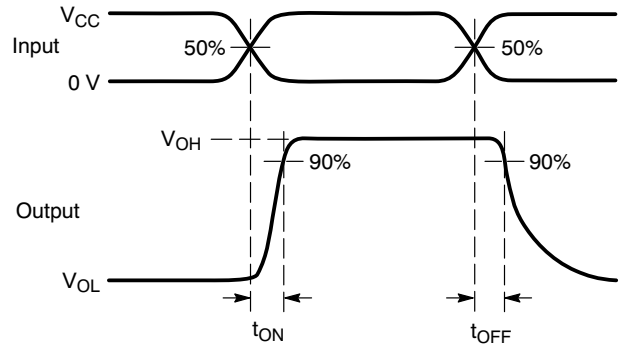
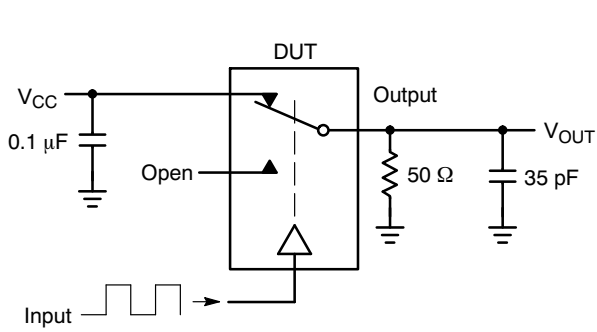

Figure 2. t_{ON} / t_{OFF} $V_{is} = V_{CC}$

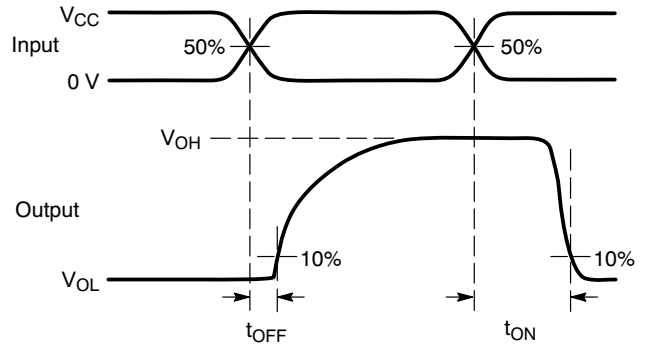
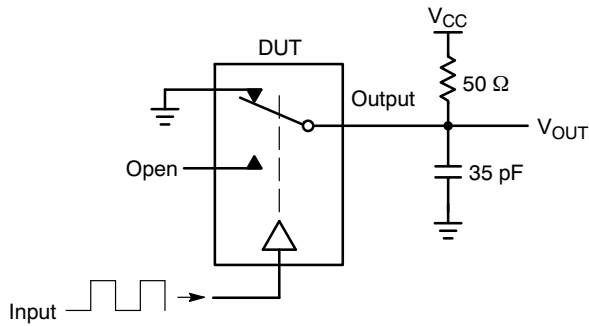
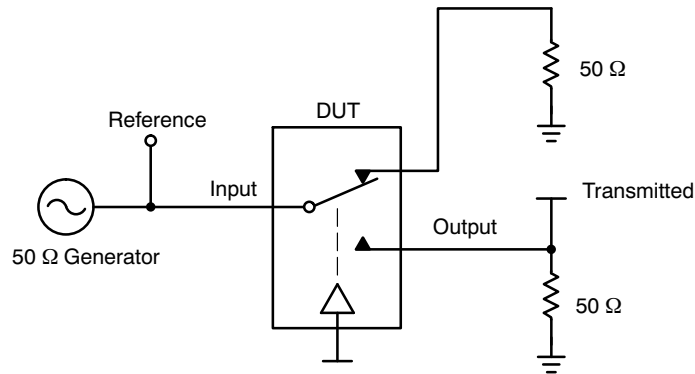

Figure 3. t_{ON} / t_{OFF} $V_{is} = GND$



Channel switch control/s test socket is normalized. Off isolation is measured across an off channel. On loss is the bandwidth of an On switch. V_{ISO} , Bandwidth and V_{ONL} are independent of the input signal direction.

$$V_{ISO} = \text{Off Channel Isolation} = 20 \text{ Log} \left(\frac{V_{OUT}}{V_{IN}} \right) \text{ for } V_{IN} \text{ at } 100 \text{ kHz}$$

$$V_{ONL} = \text{On Channel Loss} = 20 \text{ Log} \left(\frac{V_{OUT}}{V_{IN}} \right) \text{ for } V_{IN} \text{ at } 100 \text{ kHz to } 50 \text{ MHz}$$

Bandwidth (BW) = the frequency 3 dB below V_{ONL}

V_{CT} = Use V_{ISO} setup and test to all other switch analog input/outputs terminated with 50 Ω

Figure 4. Off-Channel Isolation/On Channel Loss (BW)/Crosstalk (On Channel to Off Channel)/ V_{ONL}

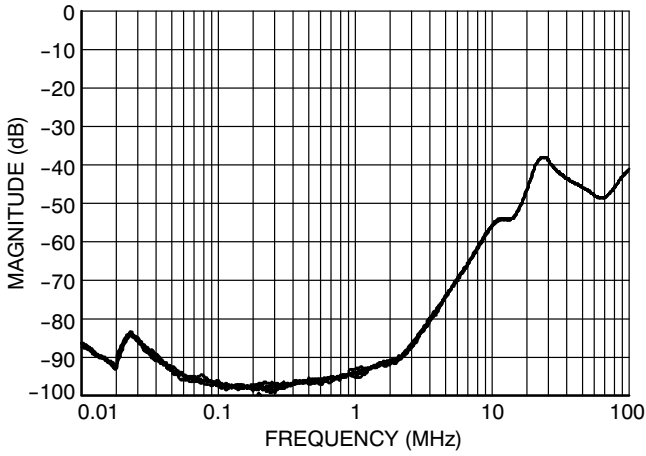

Figure 5. Crosstalk vs. Frequency @ 25°C

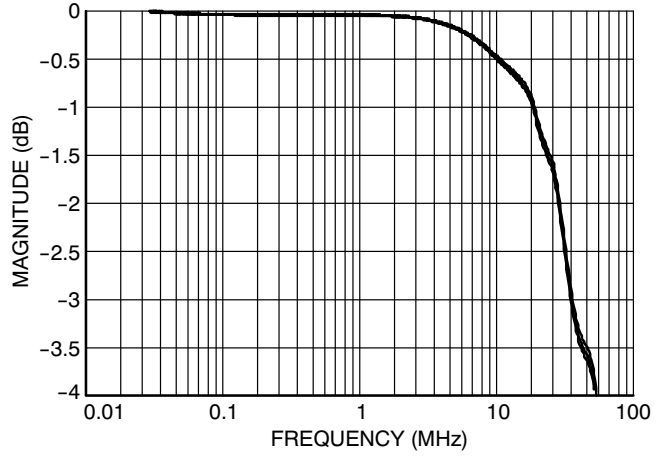

Figure 6. Bandwidth vs. Frequency @ $V_{CC} = 3\text{ V}$

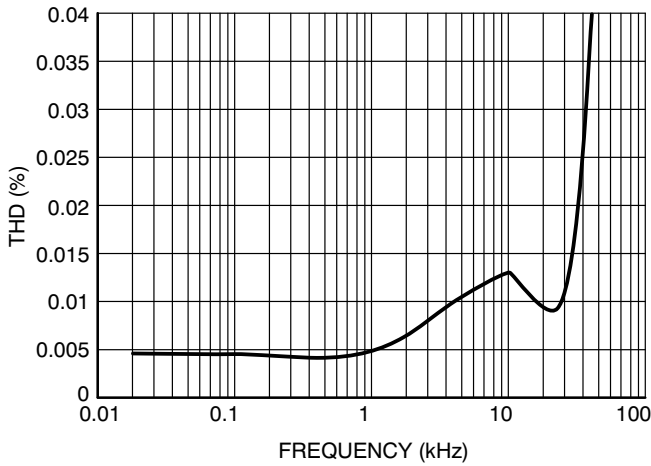

Figure 7. Total Harmonic Distortion @ $V_{CC} = 3.0\text{ V}$

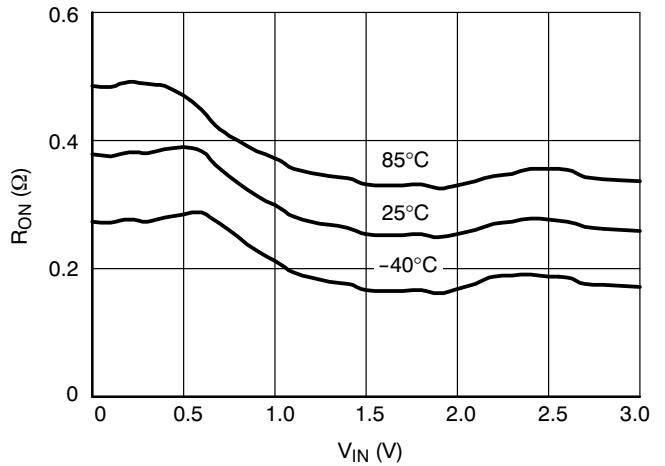

Figure 8. On-Resistance vs. Input Voltage @ $V_{CC} = 3.0\text{ V}$

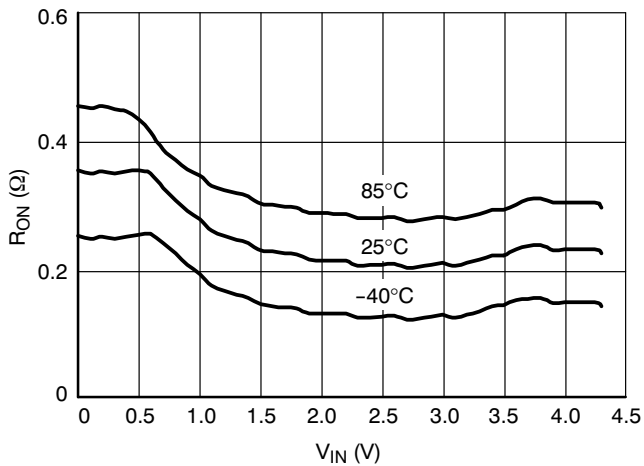

Figure 9. On-Resistance vs. Input Voltage @ $V_{CC} = 4.3\text{ V}$

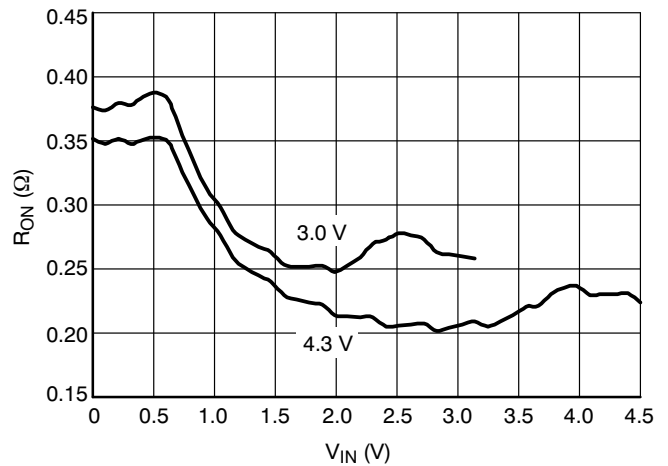

Figure 10. On-Resistance vs. Input Voltage @ 25°C

NLAS6234

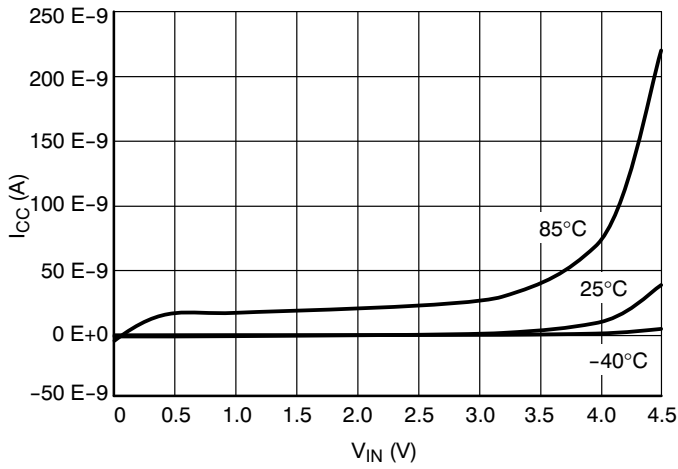

Figure 11. I_{CC} vs V_{CC}

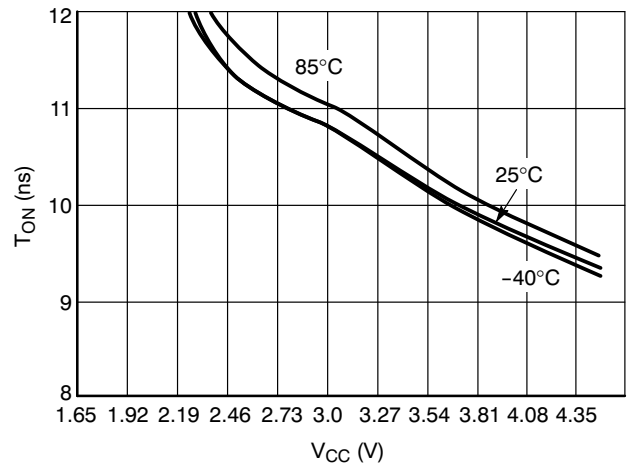

Figure 12. t_{ON} vs V_{CC}

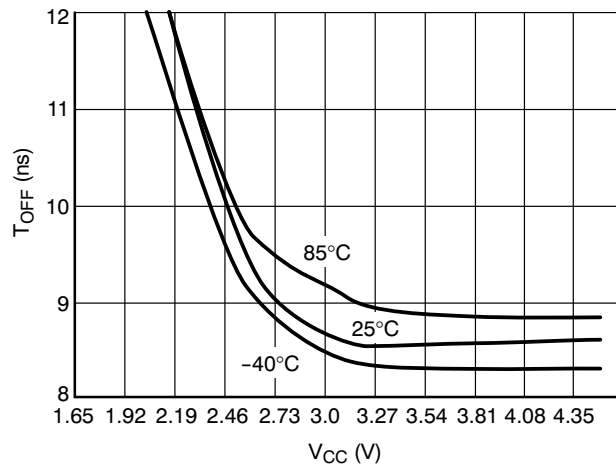

Figure 13. t_{OFF} vs V_{CC}

NLAS6234

Popless Implementation on the NLAS6234

Audio sources such as amplifiers or CODECs can generate undesirable, transient voltage spikes when powering up and down. Those voltage spikes can be translated into current surges and ultimately lead to audible pop noises in the speaker if not diverted or suppressed. The NLAS6234 includes popless noise suppression circuitry designed to prevent such undesirable pops from propagating through to the speaker. This feature is realized through a deliberate increase in the Break-Before-Make time, t_{BBM} , and is useful in applications

where a switch is used to alternate between two different audio sources.

When the signal from the common pin is removed from one terminal, the switch waits an extended amount of time before connecting to the opposite terminal. The time interval for t_{BBM} is a function of the supply voltage of the switch, V_{CC} . Figure 14 shows the relationship of t_{BBM} for each V_{CC} value within the recommended operating voltage range.

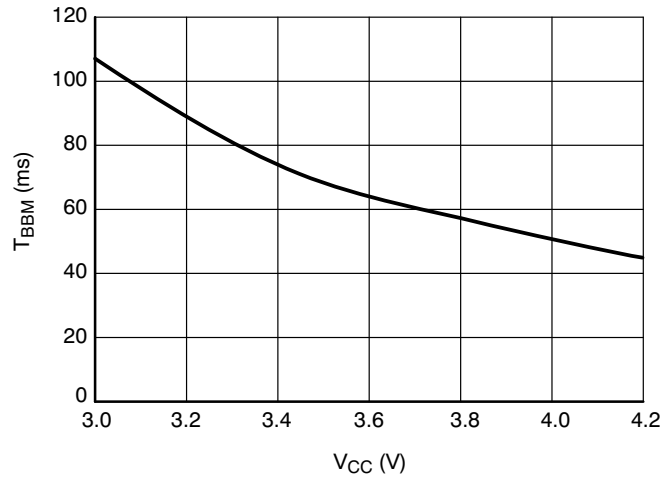

Figure 14. NLAS6234 t_{BBM} vs. V_{CC}

DEVICE ORDERING INFORMATION

Device	Package	Shipping†
NLAS6234MUTBG	UQFN10 (Pb-Free)	3000/Tape & Reel

†For information on tape and reel specifications, including part orientation and tape sizes, please refer to our Tape and Reel Packaging Specification Brochure, BRD8011/D.

MECHANICAL CASE OUTLINE

PACKAGE DIMENSIONS

ON Semiconductor®



UQFN10 1.4x1.8, 0.4P CASE 488AT-01 ISSUE A

DATE 01 AUG 2007

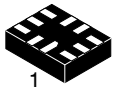

SCALE 5:1

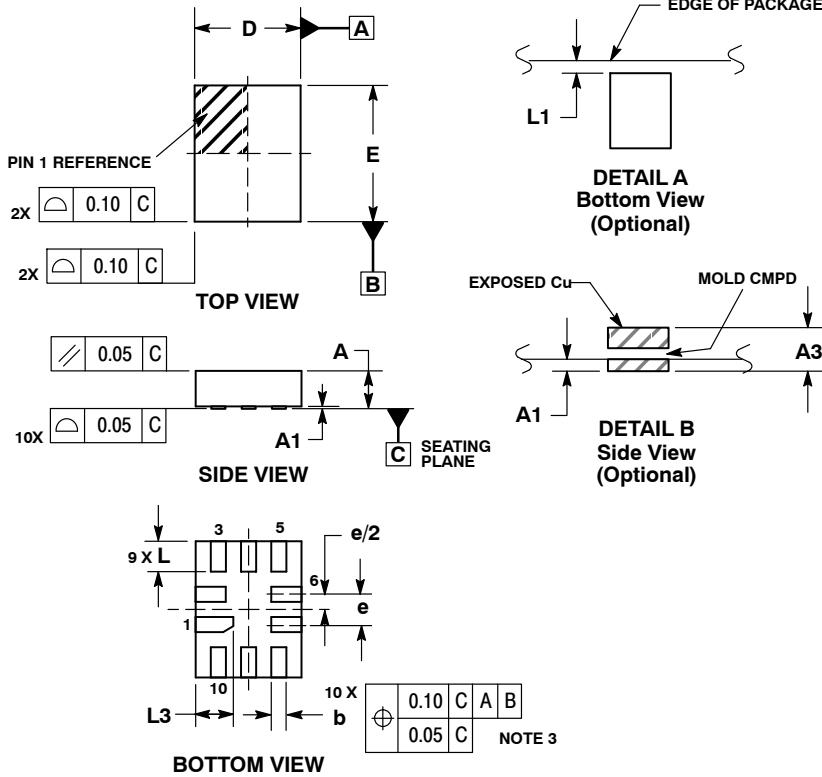

NOTES:

1. DIMENSIONING AND TOLERANCING PER ASME Y14.5M, 1994.
2. CONTROLLING DIMENSION: MILLIMETERS
3. DIMENSION b APPLIES TO PLATED TERMINAL AND IS MEASURED BETWEEN 0.25 AND 0.30 MM FROM TERMINAL.
4. COPLANARITY APPLIES TO THE EXPOSED PAD AS WELL AS THE TERMINALS.

MILLIMETERS		
DIM	MIN	MAX
A	0.45	0.60
A1	0.00	0.05
A3	0.127 REF	
b	0.15	0.25
D	1.40	BSC
E	1.80	BSC
e	0.40	BSC
L	0.30	0.50
L1	0.00	0.15
L3	0.40	0.60

GENERIC MARKING DIAGRAM*

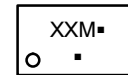

- XX = Specific Device Code
 - M = Date Code
 - = Pb-Free Package
- (Note: Microdot may be in either location)

*This information is generic. Please refer to device data sheet for actual part marking. Pb-Free indicator, "G" or microdot "▪", may or may not be present.

MOUNTING FOOTPRINT

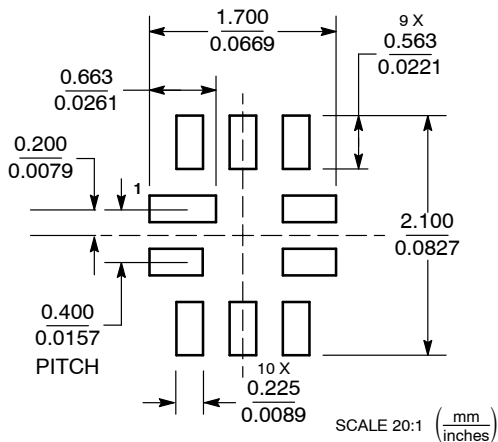

DOCUMENT NUMBER:	98AON22493D	Electronic versions are uncontrolled except when accessed directly from the Document Repository. Printed versions are uncontrolled except when stamped "CONTROLLED COPY" in red.
DESCRIPTION:	10 PIN UQFN, 1.4 X 1.8, 0.4P	PAGE 1 OF 1

ON Semiconductor and ON are trademarks of Semiconductor Components Industries, LLC dba ON Semiconductor or its subsidiaries in the United States and/or other countries. ON Semiconductor reserves the right to make changes without further notice to any products herein. ON Semiconductor makes no warranty, representation or guarantee regarding the suitability of its products for any particular purpose, nor does ON Semiconductor assume any liability arising out of the application or use of any product or circuit, and specifically disclaims any and all liability, including without limitation special, consequential or incidental damages. ON Semiconductor does not convey any license under its patent rights nor the rights of others.

onsemi, **Onsemi**, and other names, marks, and brands are registered and/or common law trademarks of Semiconductor Components Industries, LLC dba "**onsemi**" or its affiliates and/or subsidiaries in the United States and/or other countries. **onsemi** owns the rights to a number of patents, trademarks, copyrights, trade secrets, and other intellectual property. A listing of **onsemi**'s product/patent coverage may be accessed at www.onsemi.com/site/pdf/Patent-Marking.pdf. **onsemi** reserves the right to make changes at any time to any products or information herein, without notice. The information herein is provided "as-is" and **onsemi** makes no warranty, representation or guarantee regarding the accuracy of the information, product features, availability, functionality, or suitability of its products for any particular purpose, nor does **onsemi** assume any liability arising out of the application or use of any product or circuit, and specifically disclaims any and all liability, including without limitation special, consequential or incidental damages. Buyer is responsible for its products and applications using **onsemi** products, including compliance with all laws, regulations and safety requirements or standards, regardless of any support or applications information provided by **onsemi**. "Typical" parameters which may be provided in **onsemi** data sheets and/or specifications can and do vary in different applications and actual performance may vary over time. All operating parameters, including "Typicals" must be validated for each customer application by customer's technical experts. **onsemi** does not convey any license under any of its intellectual property rights nor the rights of others. **onsemi** products are not designed, intended, or authorized for use as a critical component in life support systems or any FDA Class 3 medical devices or medical devices with a same or similar classification in a foreign jurisdiction or any devices intended for implantation in the human body. Should Buyer purchase or use **onsemi** products for any such unintended or unauthorized application, Buyer shall indemnify and hold **onsemi** and its officers, employees, subsidiaries, affiliates, and distributors harmless against all claims, costs, damages, and expenses, and reasonable attorney fees arising out of, directly or indirectly, any claim of personal injury or death associated with such unintended or unauthorized use, even if such claim alleges that **onsemi** was negligent regarding the design or manufacture of the part. **onsemi** is an Equal Opportunity/Affirmative Action Employer. This literature is subject to all applicable copyright laws and is not for resale in any manner.

ADDITIONAL INFORMATION

TECHNICAL PUBLICATIONS:

Technical Library: www.onsemi.com/design/resources/technical-documentation
onsemi Website: www.onsemi.com

ONLINE SUPPORT: www.onsemi.com/support

For additional information, please contact your local Sales Representative at www.onsemi.com/support/sales