

Features

- Low Loss
- Low Ripple

Description

Surface mount, silver (Ag) coated ceramic filter for use in broadband applications.

Weight: .98 grams typical.

Material: Filter is composed of a ceramic block plated with Ag.

Filter complies with RoHS standards.

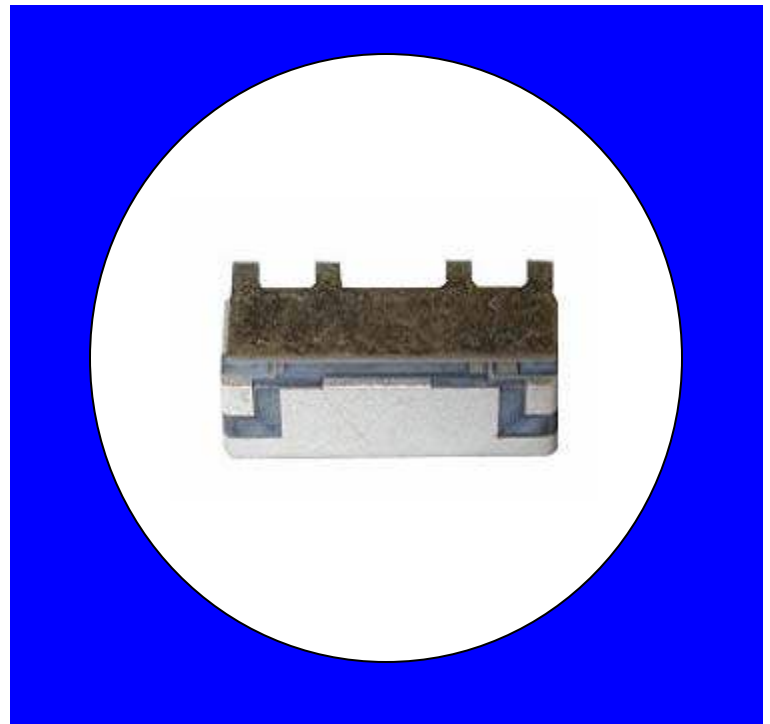

Electrical Specifications

Parameter	Frequency MHz	Typical @ 25°C	Specification @ 25°C	Spec over -40°C to +85°C
Response				
Passband Iloss	1800 - 2025	-1.2	-1.3	-1.5
Passband Ripple	1800 - 2025	0.7	0.9	1.0
Passband Return Loss	1800 - 2025	-13.5	-12.0	-12.0
Attenuation	1575	-49.0	-25.0	-25.0
	3300 - 3800	-42.0	-35.0	-35.0
	3800 - 4050	-37.0	-15.0	-15.0
Power into any port		1 Watt max		

Note: Supplier shall test each filter to the critical electrical specifications of the above table. Any subsequent audits may deviate from in value due to measurement repeatability among different test systems. Such deviations shall not exceed the following limits:

Specification Allowance	
Insertion Loss	0.1 dB
Return Loss	1.0 dB
Stopbands	1.0 dB

*This product is covered by one or more of the following U.S. and foreign patents including: US 4,692,726;US 4,742,562; US 4,800,348;US 4,829,274;US 5,146,193;EP 0573597;DE 0573597;FR 0573597;JP 508149/92;KR 142171;US 5,162,760;US 5,218,329;US 5,250,916;US 5,327,109;US 5,488,335;CA 2114029;FR 9306297;GB 2273393;JP 3205337;KR 115113;CN 93106228.4;US 5,512,866;EP 0706719;DE 0706719;FR 0706719;GB 0706719;CN 95190359.4;US 5,602,518;US 5,721,520;US 5,745,018;EP 0910875;DE 0910875;DK 0910875;FR 0910875;GB 0910875;IE 0910875;JP 505182/98;KR 10-323013;US 5,994,978;US 6,462,629;CN 00810420.4;US 6,559,735;US 6,650,202;US 6,834,429.Other US and foreign patents pending.

CTS Corporation 2006 reserves all copyrights in the layout, design and configuration of the patterns on this product.

Mechanical Drawing

Rev 1 – Origin Date: April 7, 2006 – Revision Date: June 7, 2006

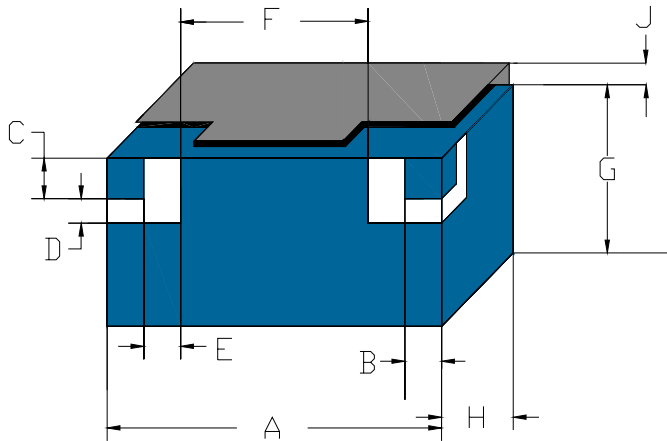

Dim	Nominal (mm)	Tolerance (mm) +/- or max
A	10.03	Max
B	1.02	0.13
C	1.02	0.13
D	1.27	0.13
E	1.27	0.13
F	6.30	0.13
G	5.02	Max
H	3.68	Max
J	0.76	0.13

Electrical response

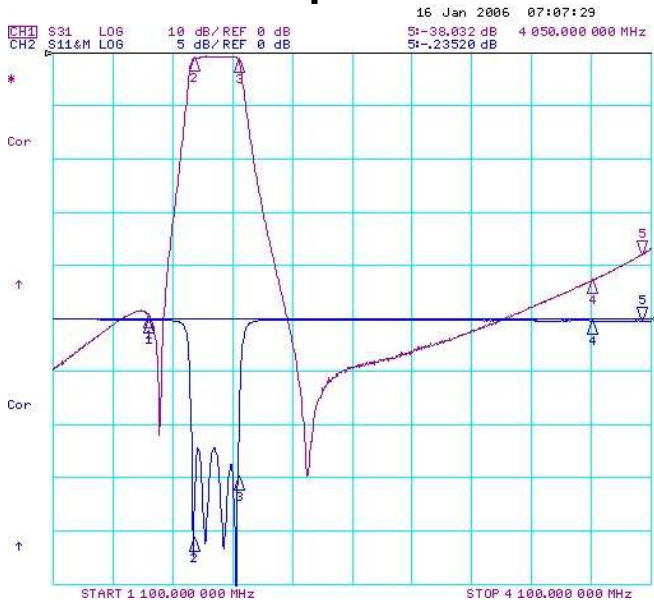

PCB Layout

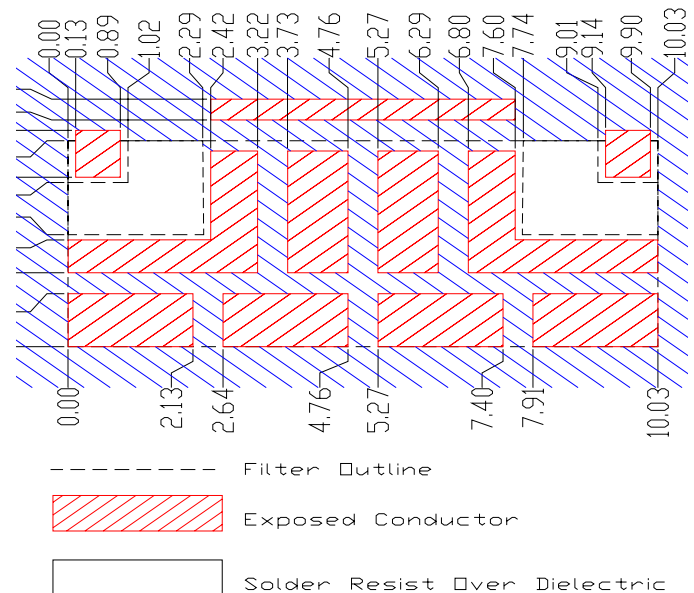

Packaging and Marking

DIMENSION	UNITS	SPECIFICATION
REEL DIAMETER	mm	330
REEL WEIGHT	kg	1.6
REEL QUANTITY	ea.	1000

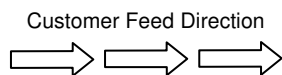

Product Marking

CTS
342
YWW

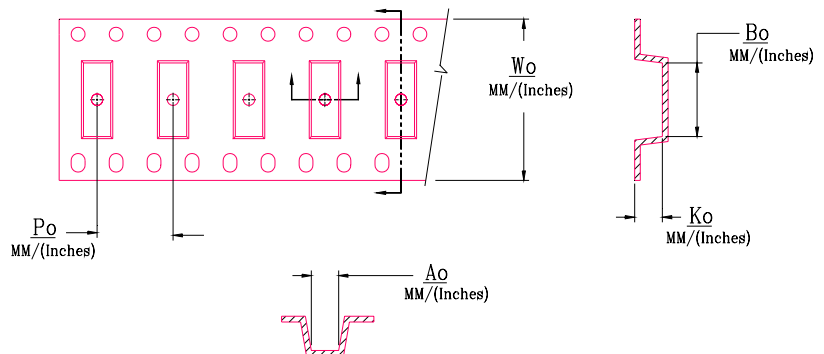

Wo	Ao	Bo	Ko	Po
Inches/mm	Inches/mm	Inches/mm	Inches/mm	Inches/mm
0.945"/24	0.319"/8.10	0.406"/10.30	0.165"/4.20	0.472"/12.00